

DIAGNOSIS GUIDE

TRANSMISSION CONTROL UNIT

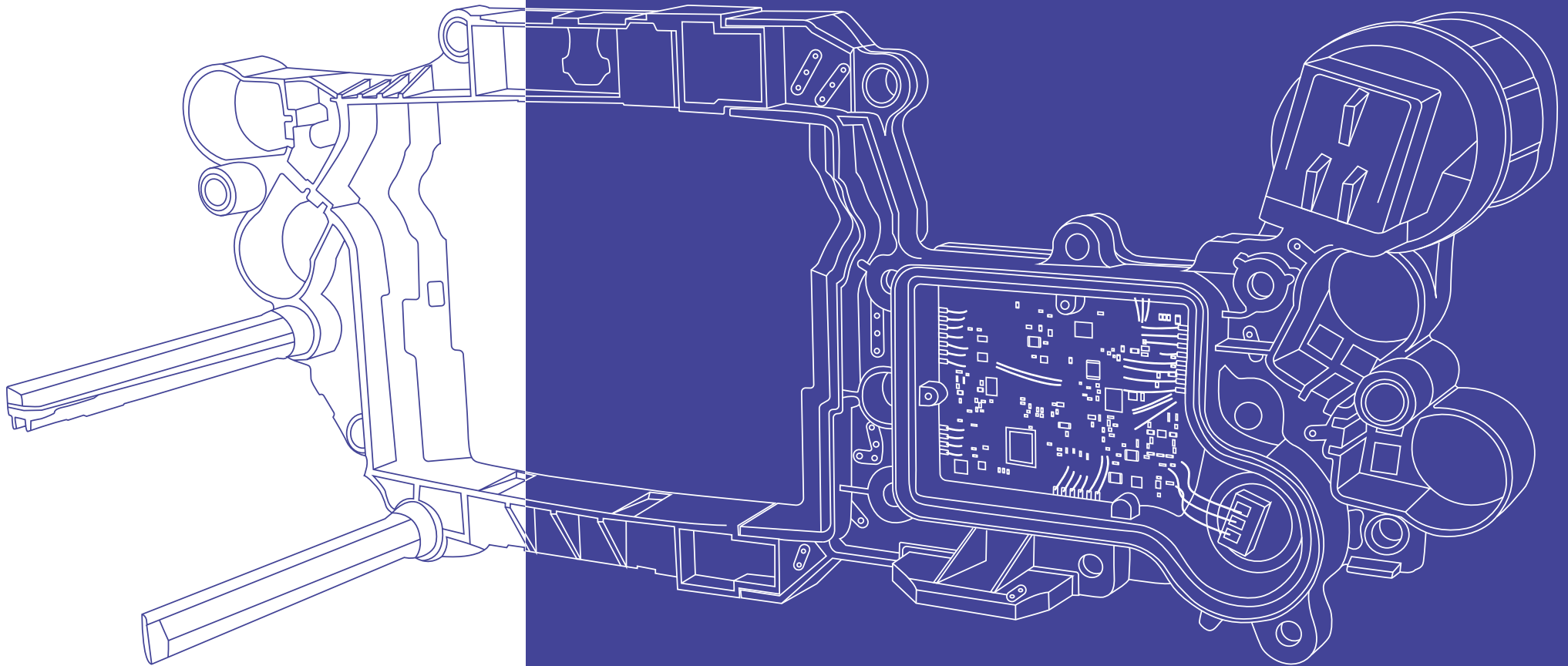

**ALL RELEVANT INFORMATION
IN ONE GUIDE**

EDITION 1

The following is described in this diagnosis guide:

All tips and tricks for installing and removing the control unit of an automatic gearbox for the following brands:

- › Audi
- › Mazda
- › Seat
- › Vauxhall
- › Ford
- › Mercedes
- › Škoda
- › Volkswagen

INTRODUCTION	3			
MERCEDES-BENZ 722.7 - SIEMENS FTC	4			
MERCEDES-BENZ A-CLASS W168 1997-2004				
MERCEDES-BENZ Vaneo W414 2002-2005				
MERCEDES-BENZ 722.8 - TEMIC VGS	18			
MERCEDES-BENZ A-CLASS W169 2004-2012				
MERCEDES-BENZ B-CLASS W245 2005-2011				
MERCEDES-BENZ 722.9 - 7G-TRONIC	32			
MERCEDES-BENZ M-CLASS W164 2006-2012				
MERCEDES-BENZ M-CLASS W166 2011-2015				
MERCEDES-BENZ SLK W171, R171 2004-2011				
MERCEDES-BENZ C-CLASS W203, CL203, S203 2000-2007				
MERCEDES-BENZ C-CLASS W204, C204, S204 2007-2014				
MERCEDES-BENZ CLK W209, A209, C209 2002-2009				
MERCEDES-BENZ E-CLASS W211, S211 2002-2008				
MERCEDES-BENZ E-CLASS W212 S212, C207, A207 2009-2016				
MERCEDES-BENZ CL-CLASS W215 1998-2005				
MERCEDES-BENZ CL-CLASS W216 2006-2013				
MERCEDES-BENZ CLS W219, C219 2004-2010				
MERCEDES-BENZ S-CLASS W220 1998-2005				
MERCEDES-BENZ S-CLASS W221 2005-2013				
MERCEDES-BENZ SL W230, R230 2001-2012				
MERCEDES-BENZ SL W231, R231 2012-2019				
MERCEDES-BENZ R-CLASS W251, V251 2006-2014				
MERCEDES-BENZ VITO / V-CLASS W447 2015-2019				
MERCEDES-BENZ G-CLASS W461, W463 1979-2019				
MERCEDES-BENZ GL-CLASS X164 2006-2012				
MERCEDES-BENZ GLK-CLASS X204 2008-2015				
DSG 6 - DQ250	48			
AUDI A3 8P 2003-2012				
AUDI TT 8N 1998-2006				
AUDI TT 8J 2006-2014				
SEAT ALHAMBRA 710 2010-2019				
SEAT ALTEA 5P1, 5P5, 5P8 2004-2015				
SEAT LEON 1P1 2005-2012				
SEAT TOLEDO III 5P2 2004-2009				
ŠKODA OCTAVIA 1Z 2004-2013				
ŠKODA SUPERB 3T 2008-2015				
ŠKODA YETI 5L 2009-2017				
VW CADDY III 2K, 2C 2004-2015				
VW CC 358 2011-2019				
VW EOS 1F7, 1F8 2006-2015				
VW GOLF IV 1J 1997-2004				
VW GOLF V 1K 2003-2009				
VW GOLF VI 5K1, 517, AJ5 2008-2012				
VW JETTA III 1K2 2005-2011				
VW JETTA IV 162, 16A 2011-2019				
VW NEW BEETLE 5C1 2011-2019				
VW PASSAT 3C2, 3C5 2005-2010				
VW PASSAT 362, 365 2010-2014				
VW SCIROCCO 137 2008-2014				
VW SHARAN 7N 2010-2019				
VW TIGUAN 5N 2007-2016				
VW TOURAN 1T1, 1T2 2003-2010				
VW TOURAN 1T3 2010-2015				
VW GOLF PLUS 5M1, 1KP 2005-2014				
DSG 7 - DQ200	70			
AUDI A1 8X 2010-2018				
AUDI A3 8P 2003-2012				
AUDI TT 8J 2006-2014				
SEAT ALTEA 5P1, 5P5, 5P8 2004-2015				
SEAT IBIZA V 6J5, 6J1, 6J8 2008-2017				
SEAT LEON 1P1 2005-2012				
SEAT TOLEDO III 5P2 2004-2009				
ŠKODA FABIA 5J 2007-2014				
ŠKODA OCTAVIA 1Z 2004-2013				
ŠKODA ROOMSTER 5J 2006-2015				
ŠKODA SUPERB 3T 2008-2015				
ŠKODA YETI 5L 2009-2017				
VW NEW BEETLE 5C1 2011-2019				
VW CADDY III 2K, 2C 2004-2015				
VW GOLF V 1K 2003-2009				
VW GOLF VI 5K1, 517, AJ5 2008-2012				
VW JETTA III 1K2 2005-2011				
VW JETTA IV 162, 16A 2011-2019				
VW PASSAT 3C2, 3C5 2005-2010				
VW PASSAT 362, 365 2010-2014				
VW POLO 6R, 6C 2009-2017				
VW SCIROCCO 137 2008-2014				
VW TOURAN 1T1, 1T2 2003-2010				
VW TOURAN 1T3 2010-2015				
VW GOLF PLUS 5M1, 1KP 2005-2014				
BOSCH EASYTRONIC - F13/F17 MTA	88			
VAUXHALL AGILA A 2000-2007				
VAUXHALL ASTRA G 1998-2004				
VAUXHALL ASTRA H 2004-2010				
VAUXHALL ASTRA J 2009-2015				
VAUXHALL COMBO C 2001-2011				
VAUXHALL CORSA C 2000-2006				
VAUXHALL CORSA D 2006-2014				
VAUXHALL MERIVA A 2003-2010				
VAUXHALL TIGRA TWINTOP 2004-2009				
VAUXHALL SIGNUM 2003-2008				
VAUXHALL VECTRA C 2002-2008				
VAUXHALL ZAFIRA B 2005-2011				
FORD DURASHIFT - EST	108			
FORD FIESTA V 2001-2008				
FORD FUSION 2002-2012				
MAZDA 2 2003-2007				
MAZDA 2 2007-2014				
INDEX: SEARCH BY BRAND AND MODEL	126			
DISCLAIMER AND COPYRIGHT	127			

TCU PROBLEMS? ACTRONICS IS HAPPY TO HELP YOU ON YOUR WAY!

The work of a car mechanic today consists to a significant extent of diagnosing and solving electronic problems. We are all too aware that this can be very difficult in certain cases. A TCU is, of course, a great piece of technology as long as it works well, but what should you do if problems arise? And where can you find the necessary information and instructions? Resorting to Google may often provide a solution, but there, too, not all relevant information can be found in one central place.

So it's about time to change this. ACtronics therefore presents a diagnostic guide that is specifically aimed at TCUs.

The following is described in this diagnostic guide:

- › Known complaints
- › Relevant error codes
- › Pin assignment
- › Schematics
- › Detailed technical information
- › Various removal and installation tips
- › How to offer for remanufacturing

We treat each TCU according to a fixed structure, so that you always have the necessary information at your fingertips. In short: This ACtronics diagnostic manual is the ideal reference for any workshop.



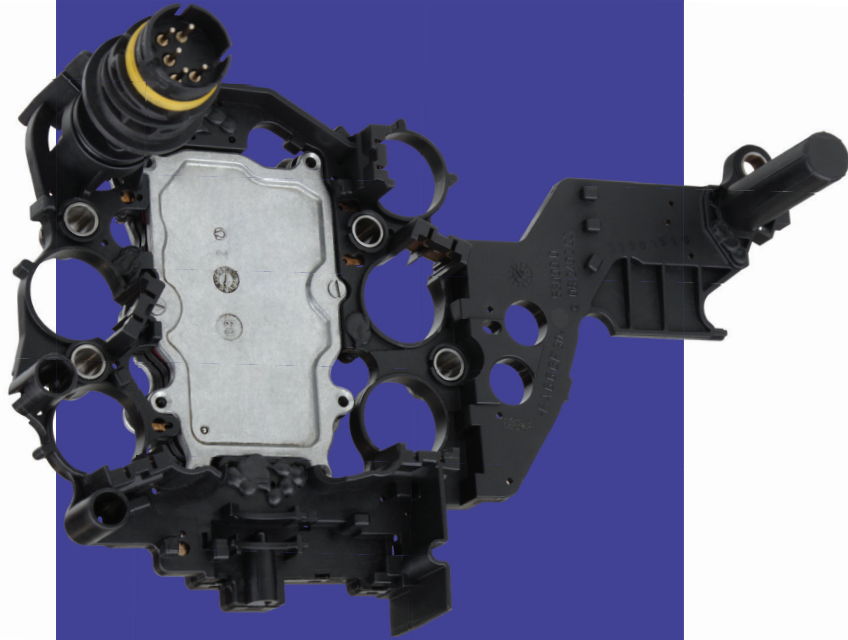

MERCEDES-BENZ 722.7 SIEMENS FTC

Mercedes-Benz ran into quite a bit of trouble when it decided to add a small vehicle to its range. The car not only had to be compact and practical but also had to deliver a lot in terms of comfort and luxury. After all, it was a Mercedes-Benz. The 722.7 gearbox has the layout of a conventional manual gearbox, but uses a torque converter and several small hydraulic clutches to shift between gears. In our opinion, this is a very nice solution for this type of car.



MERCEDES-BENZ A-CLASS W168 1997-2004

Mercedes-Benz 722.7 Siemens FTC

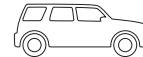

MERCEDES-BENZ Vaneo W414 2002-2005

Mercedes-Benz 722.7 Siemens FTC

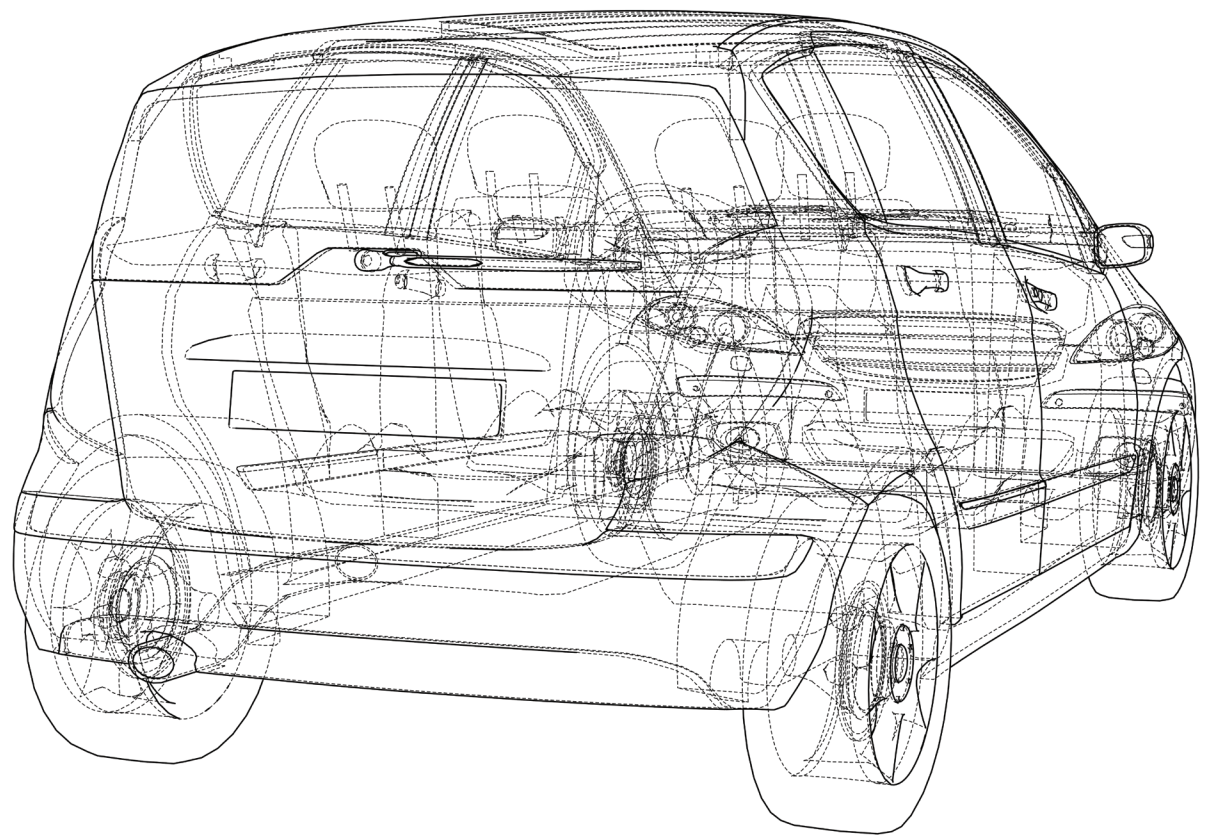

KNOWN COMPLAINTS

- › An "F" appears on the display.
- › The car goes into limp mode
- › The gearbox no longer shifts
- › The gearbox shifts randomly to "N" or an illogical gear
- › The car won't start

CAN BE REMANUFACTURED

OBD II	Description
P1840 (2120)	PWM solenoid valve 1 / 4 shift
P1841 (2121)	PWM solenoid valve 3 shift
P1842 (2122)	PWM solenoid valve 2 / 5 / R shift
P1843	PWM solenoid valve torque converter lock-up clutch
P1844	PWM shift valve circuit
P1850 (2204)	Transmission RPM sensor Y3/7n1
P1858 (2227)	Starter lockout contact
P1884 (2123)	PWM shift valve pressure
P1897	Control module N15/7 faulty
P1903	Control module N15/7 faulty

REMANUFACTURE MAY BE POSSIBLE ADDITIONAL DIAGNOSIS REQUIRED

OBD II	Description
P1895 (200a)	Internal fault in control unit

This error code will never actually appear independently. Therefore, look carefully at the rest of the error codes to make the correct diagnosis.

OBD II	Description
P1709	Park / Neutral switch
P1756	Selector lever implausible
P1872	CAN signal from gear recognition module faulty
P1875	CAN communication ESP
P2031	No signal or error signal from control unit N15/5
P2210	Selector lever coding is invalid
P2211	The selector lever is in an intermediate position
P2212	The selector lever position is implausible
P2318	Fault in CAN communication with control unit N15/5
P2333	The CAN signal from control unit N15/5
P2338	The CAN signal from control unit N15/5
2310	CAN communication with TCS failed
2311	CAN communication with ECU failed
2312	CAN communication with ECU failed
2315	CAN communication with instruments failed
2316	CAN communication with A/C failed
P240C	The CAN signal for the selector lever position from control unit N15/5

These error codes may indicate that the gear selector lever is defective. In many cases, this is also revisable.

If in doubt, please contact our Customer Service.

Telephone: 01206 849920

CANNOT BE REMANUFACTURED

OBD II	Description
P1886	1-4 / -3 downshift PWM valve pressure too low OR 2-5-R pressure too high
P1887 (2531)	1-4 or 2-5 shift slide valve jamming in basic position Shift valve pressure too low
P1888	1-4 or 2-5 shift slide valve jamming in basic position Shift valve pressure too high
P1889	2-5-R downshift PWM valve pressure too low Transmission slipping
P1893	Pressure too high at regulating valve or solenoid valve 1 / 4 or 3

These error codes often indicate mechanical defects. Check the gearbox carefully for wear and/or damage!

PIN ASSIGNMENT

Pin 3	K-line
Pin 5	CAN high
Pin 6	Power supply 12V +30
Pin 7	Ground 31
Pin 8	CAN low

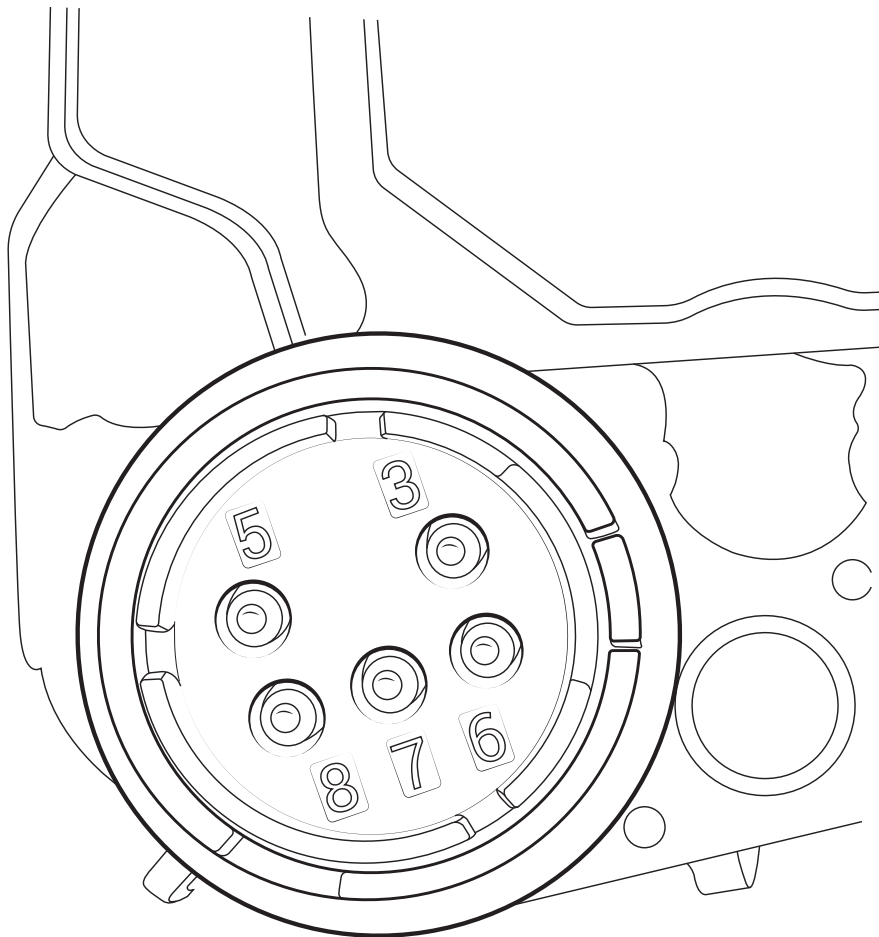

GENERAL OPERATION

The 722.7 automatic gearbox is an electro-hydraulically controlled 5-speed gearbox, which also features a torque converter. "FTC" stands for "Front Transmission Control". The next gear is selected via hydraulically operated multi-plate clutches. Each gear has its own multi-plate clutch. These replace the conventional forks used in a manual gearbox. Mechanically, the 722.7 looks a lot like a manual 5-speed gearbox.

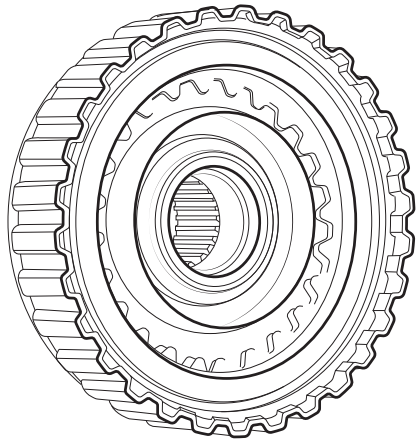

The Mechatronic is mounted on the underside of the gearbox. If required, control valves direct oil pressure towards the various clutches. The required oil pressure for the K3, K4 and lock-up clutches is fed through holes in the main shaft. The oil pressure for the K2 and KR clutches runs through the opposite shaft.

In addition to transferring oil pressure, the shafts in the gearbox are also used for the distribution of lubricating oil. In this way, various bearings as well as all the multi-plate clutches are supplied with lubricating oil.

Opted for the torque converter

The addition of a torque converter is not necessary from a technical point of view because this could also have been done with a (slightly cheaper) automated plate clutch. However, a torque converter completes the total "Mercedes feeling". A torque converter creeps in: something that the automatic transmissions in the more expensive Mercedes-Benz models also have. In addition, a torque converter multiplies the engine torque until it stops slipping. A feature that especially low-torque engines can benefit greatly from when pulling away. Are you curious about how a torque converter works? Then continue to the next TCU in this Diagnostic Guide: Mercedes-Benz 722.8 - Temic VGS.

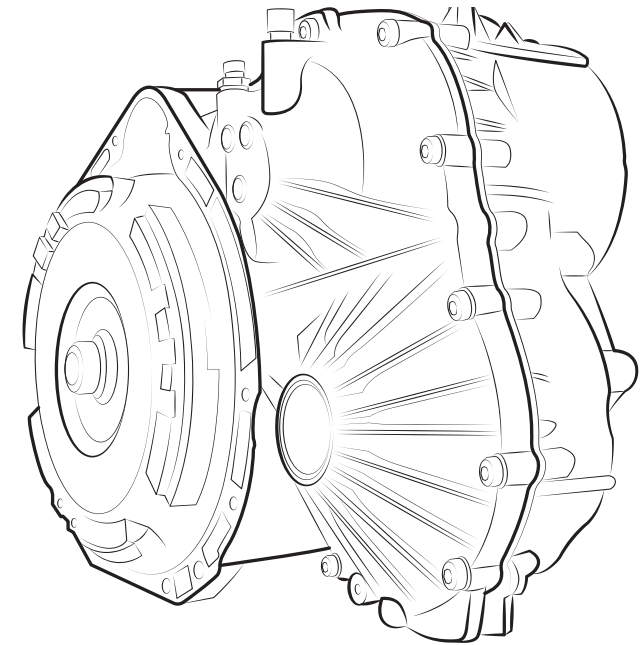

The Mercedes-Benz 722.7 gearbox with torque converter

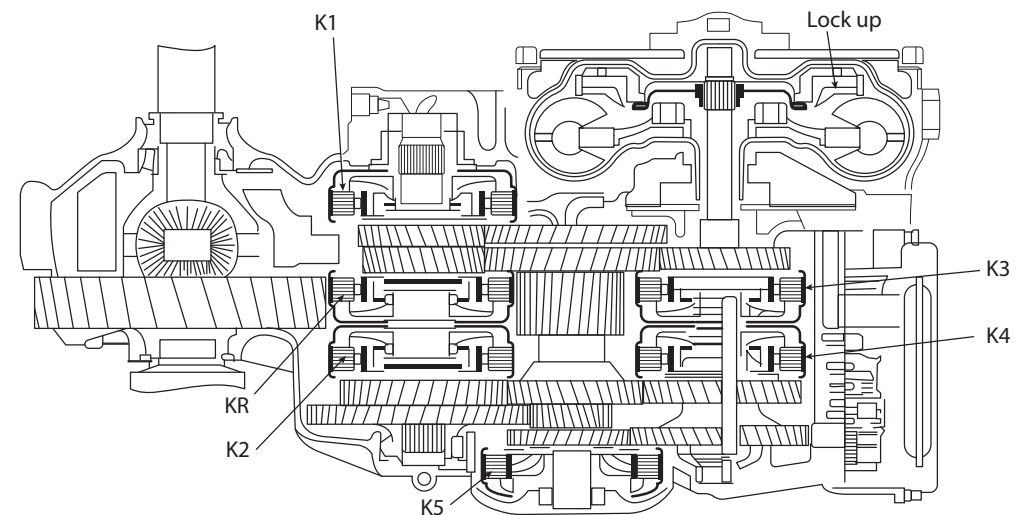

THE MECHATRONIC IN DETAIL

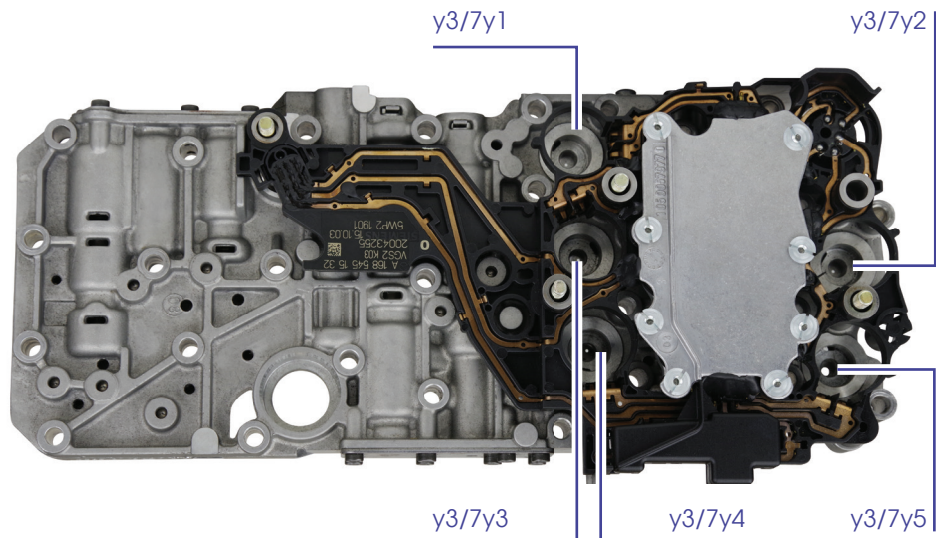

Actuator	Function
Y3/7y1	Control valve "for 1st and 4th gear"
Y3/7y2	Control valve "for 3rd gear"
Y3/7y3	Control valve "for 2nd, 5th and "R" gears"
Y3/7y4	Control valve for lock-up
Y3/7y5	Shift valve

Hydraulic clutch control operation

The labyrinth mounted underneath the TCU (=Transmission Control Unit) is equipped with several control valves and shift valves. By controlling the control valves (also known as solenoid valves), the fluid pressure can be directed towards these valves. This ensures that the valves are adjusted to the correct position. This allows fluid pressure to flow to the various multi-plate clutches. As soon as the clutch is engaged, the gear is engaged. In this regard, the 722.7 differs substantially from a manual gearbox.

A total of 5 control valves are used. As can be seen in the following diagram, control

valve Y3/7y4 controls the lock-up clutch. The other valves work together to operate the other clutches (e.g. K1 = the clutch of gear 1):

Shift diagram

Valve name	K1	K2	K3	K4	K5	KR
Y3/7y1 via valves RS14 and SS14	≈	0%	0%	≈	0%	0%
Y3/7y2 via valve RS3	0%	0%	≈	0%	0%	0%
Y3/7y3 via valves RS25R and SS25	100%	≈	100%	100%	≈	≈
Y3/7y4 Lock-up clutch	≈	≈	≈	≈	≈	0%
Y3/7y5 Shift valve	100%	100%	100%	0%	0%	100%

Similar control valves

4 of the 5 control valves in this Mechatronic are of the normally closed solenoid type. This means that the valves are closed when de-energised and do not allow any liquid to pass through. This means that control valves Y3/7y1, Y3/7y2, Y3/7y3 and Y3/7y4 can be exchanged without penalty.

Valve Y3/7y5 is another case. This is not a control valve, but a shift valve: the valve can only be opened to the maximum or closed to the maximum. In addition, this valve works with a different voltage.

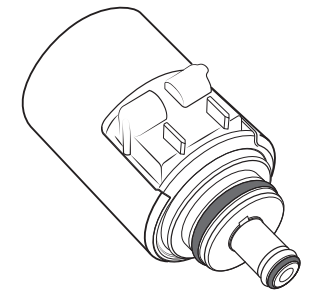

A normally-closed-solenoid.



Tip in case of unusual shifting complaints:

The shift diagram can also be used for diagnostic purposes. If, for example, the car does not want to shift to 3rd gear, this could be due to clutch K3, but of course also to a defective control valve. In this case, Y3/7y2 is the valve that has to be additionally switched. By changing the position of this control valve, the complaint (and corresponding error codes) should move to the new position. Unfortunately, the control valves cannot be extensively tested using diagnostic software.

THE TCU IN DETAIL

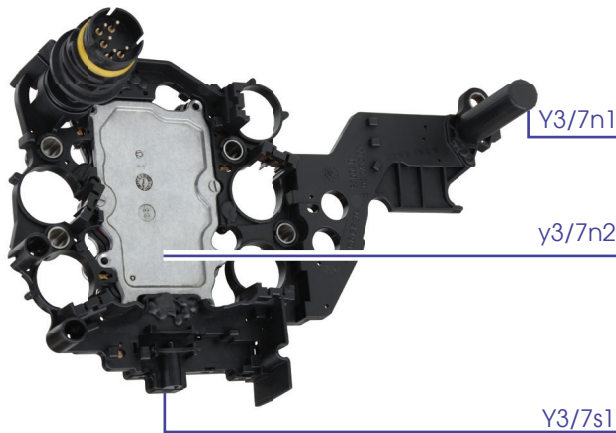

Sensor	Function
Y3/7n1	Speed sensor
Y3/7n2	Control module
Y3/7s1	Starter lockout

This type of TCU is relatively simple: 1 plug, 1 speed sensor, 1 switch for the starter lockout and 1 central control module.

Communication with the rest of the vehicle is completely via CAN. As a result, the plug only needs 5 connections.

The speed sensor uses the Hall principle: a change in the magnetic field generates an electronic signal. This signal can also mimic itself. In "Workshop tip" (see below), we explain how this can be applied in a useful way.

Limp mode

After the TCU has detected an electrical fault or measures an unexpected coupling pressure, it will always activate the limp mode. The electronic part of the Mechatronic is completely switched off. This means that all control valves are in a Voltage-Free State. This will increase the overall working pressure to the maximum value, the lock-up clutch will disengage and the gearbox will shift to 5th gear and stay in it (the only gear that can operate with 0% pressure from all valves).



It is still possible to shift to "2" and "R" in a limp mode: leave the selector lever in "P" for 10 seconds before selecting "D" or "R" when the vehicle is stationary.



Check the sensor function yourself

If the car from which the TCU comes is still available, the speed sensor of the extended TCU is quite easy to check by yourself. The only condition is that a diagnostic tool is needed to make live data visible.

Proceed as follows:

1. Connect the connector from the car to the separate TCU
2. Turn on the ignition (power supply)
3. Find the required live data in the reader
4. Use a magnetic screwdriver to move along the sensor several times

The frequency at which the screwdriver passes the sensor now becomes visible as the speed.



N.B.:

If live data are not available, the operation can also be measured via the copper tracks at the rear of the speed sensor. Use a multimeter for this. Between track 1 and track 3, the voltage will change between 0 volts and 5 volts each time a magnetic screwdriver is moved past the sensor.

REMOVING THE MECHATRONIC

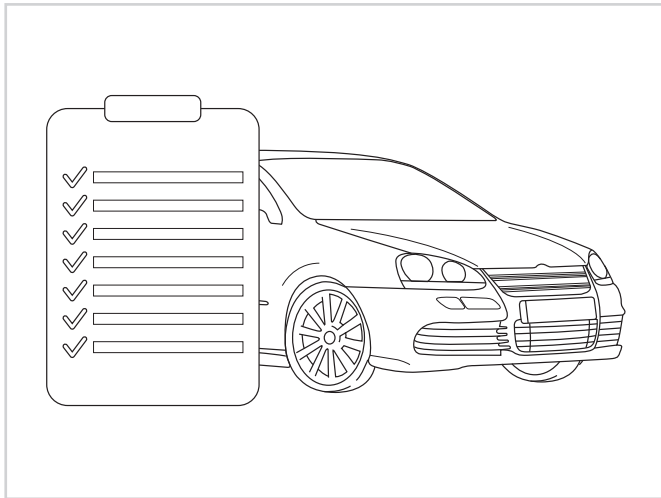

Preparation

1. Apply the car's handbrake.
2. Set the gearbox to "P".
3. If there is a radio with a radio code, make sure the radio code is known before disconnecting the battery.
4. Remove the ground wire from the battery.
5. Remove the base plate.
6. Remove the plug from the Mechatronic: turn the outer ring anticlockwise.

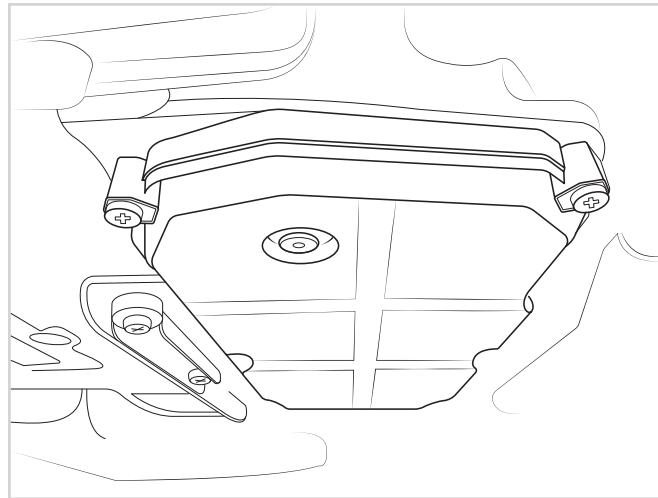

Sump pan disassembly

1. Place a drip tray with a capacity of at least 6 litres under the sump.
2. Unscrew the sump plug and drain the gearbox oil.

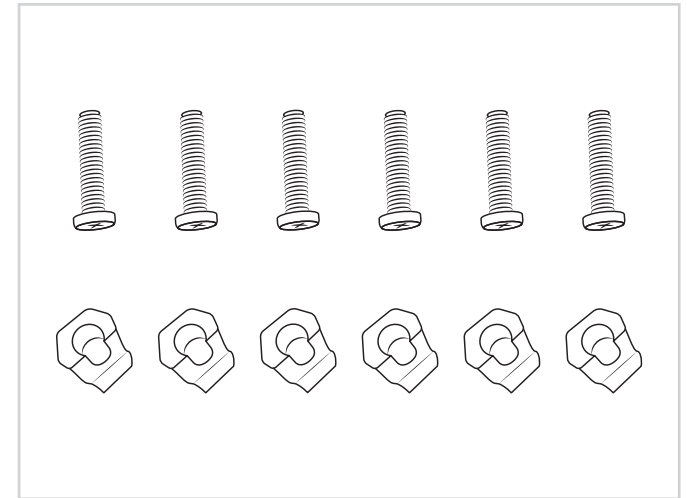

3. Loosen the 6 sump bolts with clamps.
4. Take the sump off the gearbox.



ATTENTION:

Often there is still a quantity of oil in the sump during disassembly. Therefore keep the sump upright at all times during disassembly. Also make sure an oil catch tray is placed under the sump.

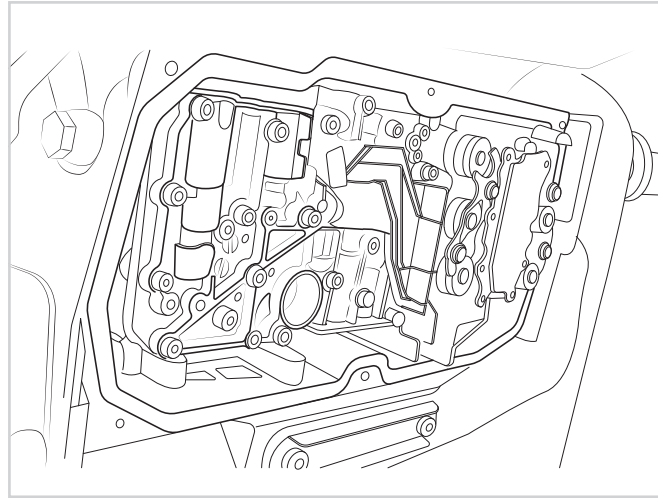
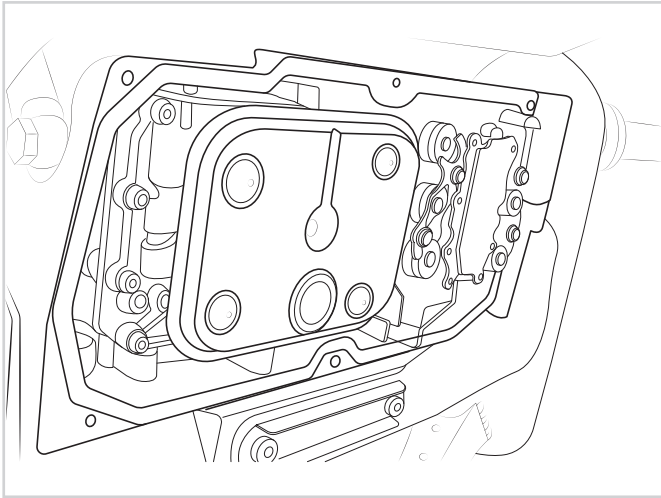

Mechatronic disassembly

1. Remove the oil filter. It is clamped in position without screws.
2. Loosen the 25 (!) bolts with which the Mechatronic is fastened. Ensure the Mechatronic is supported while doing this.
3. Lower the Mechatronic out of the gearbox. If it sticks, push the plug into the gearbox with little force.

OFFER FOR REMANUFACTURE

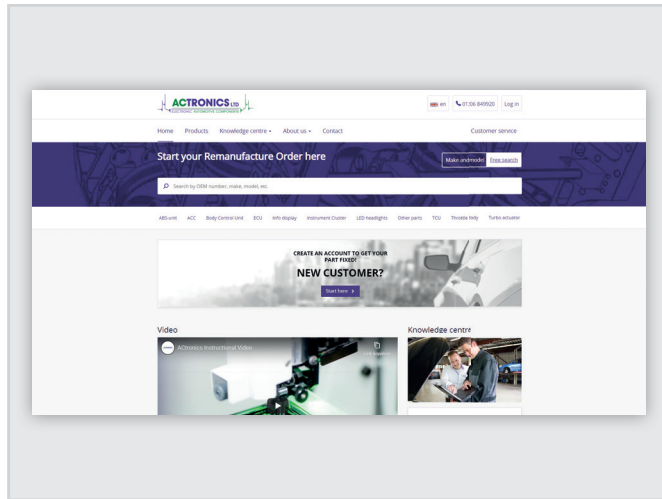

Sign up online

- › Go to www.actronics.co.uk and click on "Free search".
- › Then enter "Siemens ftc" and the product will immediately appear on the screen.
- › Click on "View product" and follow the dropdown menu.
- › You have now selected the right product.
- › Now click on "Next" and log in to complete the registration.
- › Print the [Remanufacture Order Form](#) after registration.

Shipping

In order to prevent transport damage, the Siemens FTC should always be sent in **without a hydraulic block**. We always ship the TCU back to you in specially developed transport packaging. We do this because the long sensors are extremely fragile. When packing, make sure that the sensor arms are particularly well protected!



ATTENTION:

Enclose the printed Remanufacture Order Form with the product in the transport packaging. This is crucial for identification upon receipt.

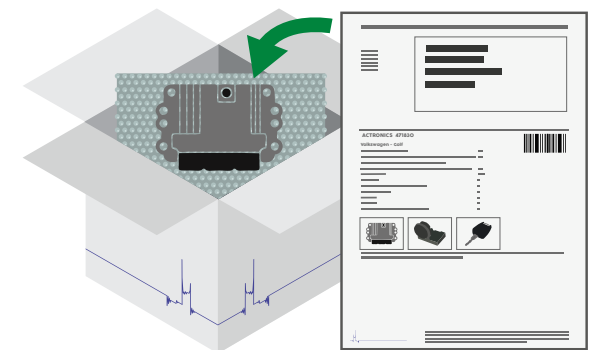

INSTALLING THE MECHATRONIC AFTER REMANUFACTURING

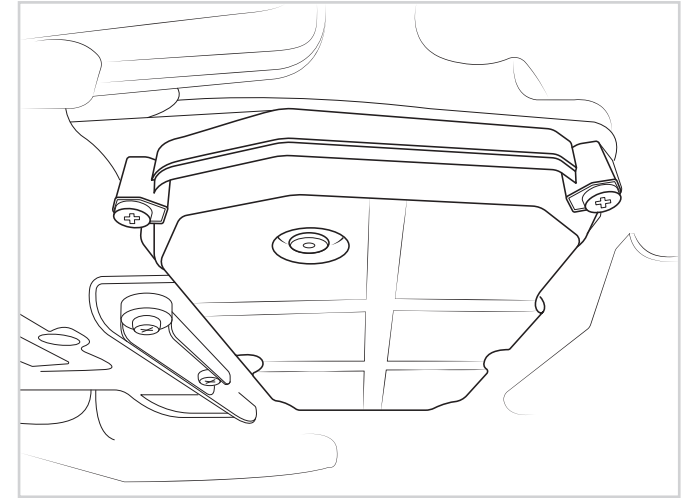
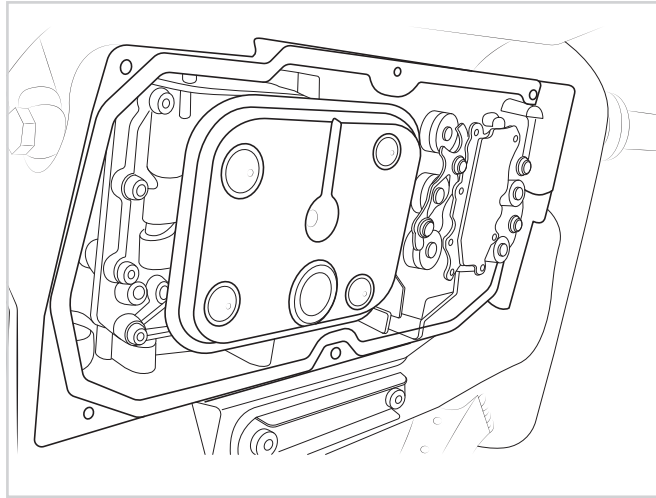
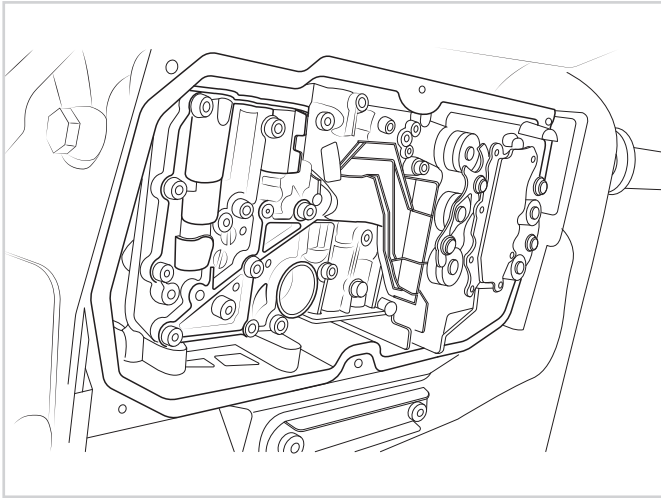
**Mounting the Mechatronic**

1. Before mounting, check the O-ring of the plug for damage. If in doubt, replace the O-ring.
2. Place the Mechatronic back into the gearbox. Pay close attention to the position of the plug and the control of the starter lockout.
3. Tighten the 25 (!) bolts crosswise. Tightening torque: 8 Nm.

4. Install a **new** oil filter. This is clamped in place, not screwed on.

Sump assembly

1. Use a **new** sump gasket.
2. Place the sump and gasket back onto the gearbox and secure it with 6 bolts and 6 clamps as shown. Tightening torque: 8 Nm.
3. Install and tighten the sump plug with a **new** sump plug ring. Tightening torque: 22 Nm.

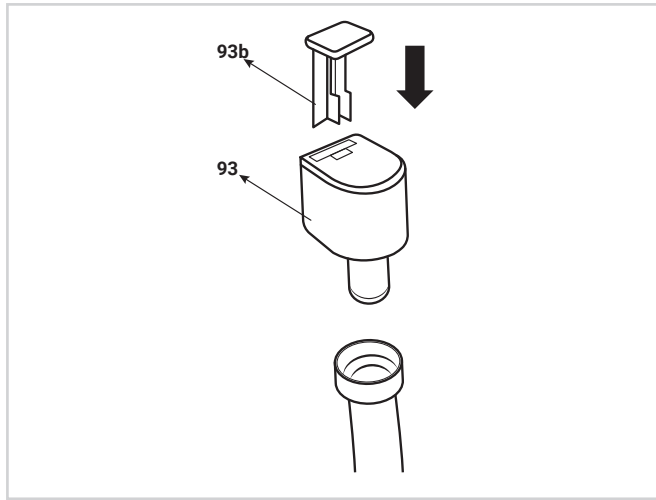
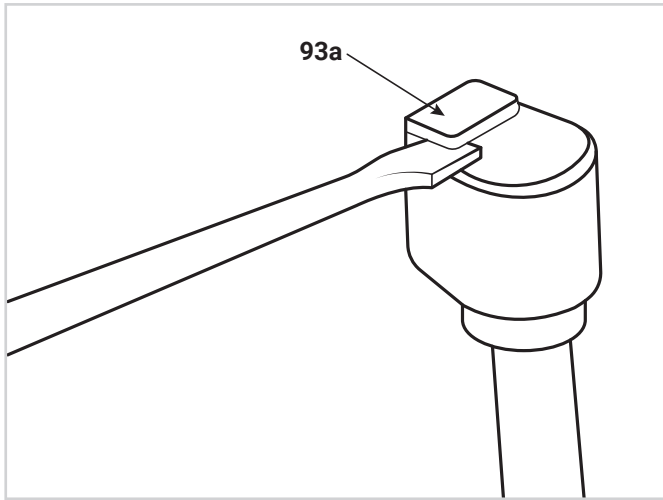

Adding gearbox oil

1. Remove locking plate "93a" from oil filler cap "93" and press down the remaining part of latch "93b" to remove it.
2. Remove oil filler cap "93" and first top up the gearbox with 3 litres of oil (MB 236.10 recommended).

3. Start the engine and select "P", "R", "N" and "D" several times.
4. Check the oil level while the engine and gearbox are idling in the "P" position. Use the Star Diagnostic device to be able to read the current gearbox temperature.

The level is correct for the following values:

Cold: Between the 2nd and 4th dash from the bottom
At 80 °C: Between the 8th and 12th dash from the bottom



ATTENTION:

Filling with too much or too little oil can negatively affect the functioning of the CVT transmission and even lead to damage. Use a hand pump to suck up any excess oil.

5. If necessary, top up and check again.
6. Replace oil filler cap "93".
7. Insert a **new** latch "93b" and make sure it locks securely
8. Check the CVT transmission for leaks.
9. Reinstall the plating on the underside of the engine compartment.



MERCEDES-BENZ 722.8

TEMIC VGS

Both the Mercedes-Benz A-Class (W169) and the B-Class (W245) are equipped with a Mercedes-Benz Temic VGS 722.8: a CVT (Continuously Variable Transmission) with torque converter. This combination was deliberately chosen because a CVT usually takes up relatively little space and yet still works very comfortably. Making it ideal for a smaller Mercedes-Benz.



MERCEDES-BENZ A-CLASS W169 2004-2012

Mercedes-Benz 722.8 - Temic VGS



MERCEDES-BENZ B-CLASS W245 2005-2011

Mercedes-Benz 722.8 - Temic VGS

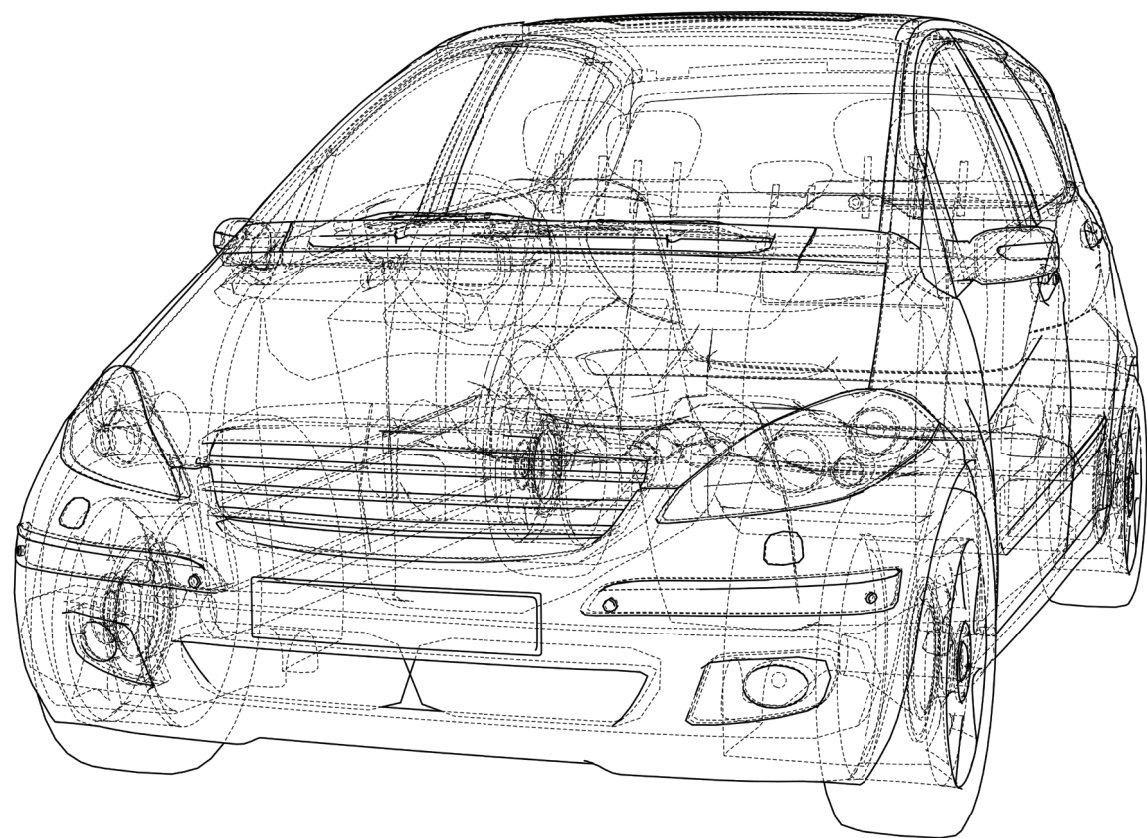

! KNOWN COMPLAINTS

- › The car goes into limp mode
- › The gearbox no longer shifts
- › The gearbox shifts randomly to "N" or an illogical gear

✓ CAN BE REMANUFACTURED

OBD II	Description
P0657	The voltage supply of the control unit solenoid valves in the CVT is faulty
P0705	Transmission range sensor circuit malfunction
P0717	The RPM signal from component Y3/9b3 (CVT input RPM sensor) is not available
P0720	Output speed sensor malfunction
P0722	The RPM signal from component Y3/9b5 (CVT output rpm sensor) is not available
P0739	Secondary RPM signal of component Y3/9b5 is not available
P0741	Actuation of torque converter clutch not possible
P0793	Intermediate shaft speed sensor circuit Y3/9b4 no signal
P0842	The output voltage or component pressure sensor is faulty (short circuit to ground)
P0843	The output voltage or component pressure sensor is faulty (short circuit to positive)
P0896	Impermissible adjustment of the step-down ratio in the CVT
P1634	Component Y3/9n1 (CVT) is defective or the voltage supply is faulty (undervoltage)
P2722	Impermissible closing of hydraulic clutch
P2731	Impermissible closing of hydraulic clutch

The error codes in **bold** may appear on their own or in combination with other error codes listed above. Remanufacture is only necessary in combination with other relevant error codes.

If in doubt, please contact our Customer Service.

Telephone: 01206 849920

REMANUFACTURE MAY BE POSSIBLE ADDITIONAL DIAGNOSIS REQUIRED

OBD II	Description
P0706	The signals of the range selector are implausible in comparison to the signals from the electronic selector lever module
P0718	The RPM signal from component Y3/9b3 (CVT input RPM sensor) is implausible
P0723	The RPM signal from component Y3/9b5 (CVT output RPM sensor) is implausible
P0794	Intermediate Shaft Speed Sensor Circuit Y3/9b4 Intermittent

For the above error codes, first check the sensors for contamination by metal particles. This can also be a thin grey (greasy) layer.

If there is any contamination, check the gearbox thoroughly for mechanical wear/damage. The image below shows where the critical points are located.

Then clean the sensor(s) and check that the error code remains present. If this is the case, then it is still plausible that the TCU is defective and needs to be remanufactured.

If in doubt, please contact our Customer Service.

Telephone: 01206 849920

CANNOT BE REMANUFACTURED

OBD II	Description
P0730	The gear ratio in the CVT is not permissible

Possible causes for this error code to appear:

- › Contaminated gearbox oil
- › Failing shift solenoids
- › Various mechanical defects in the gearbox
- › Various hydraulic defects in the gearbox

OBD II	Description
P0841	While driving, the actual hydraulic pressure is implausible in comparison with the specified hydraulic pressure in the CVT
P0868	Transmission fluid pressure low
P2723	Impermissible opening of hydraulic brake "reverse gear" has occurred in the continuously variable automatic transmission (CVT) when selector lever "N" was engaged
P2732	Impermissible opening of hydraulic clutch "forward gear" has occurred in the CVT

The above error codes appear when hydraulic pressure is lost. This may be due to the blue and white O-ring in the hydraulic block (see chapter "The Mechatronic in detail") or cracks in the hydraulic block itself. Contaminated gearbox oil can also be a cause. Always flush the gearbox and check the hydraulic block thoroughly if these error codes are seen.

OBD II	Description
P0984	The steel tension belt in the CVT is slipping

The slipping of the tension belt can have several causes. However, this is often due to mechanical wear. In some cases it may be necessary to replace the tension belt and/or other components in their entirety.

CRITICAL AREAS FOR MECHANICAL WEAR IN THE GEARBOX

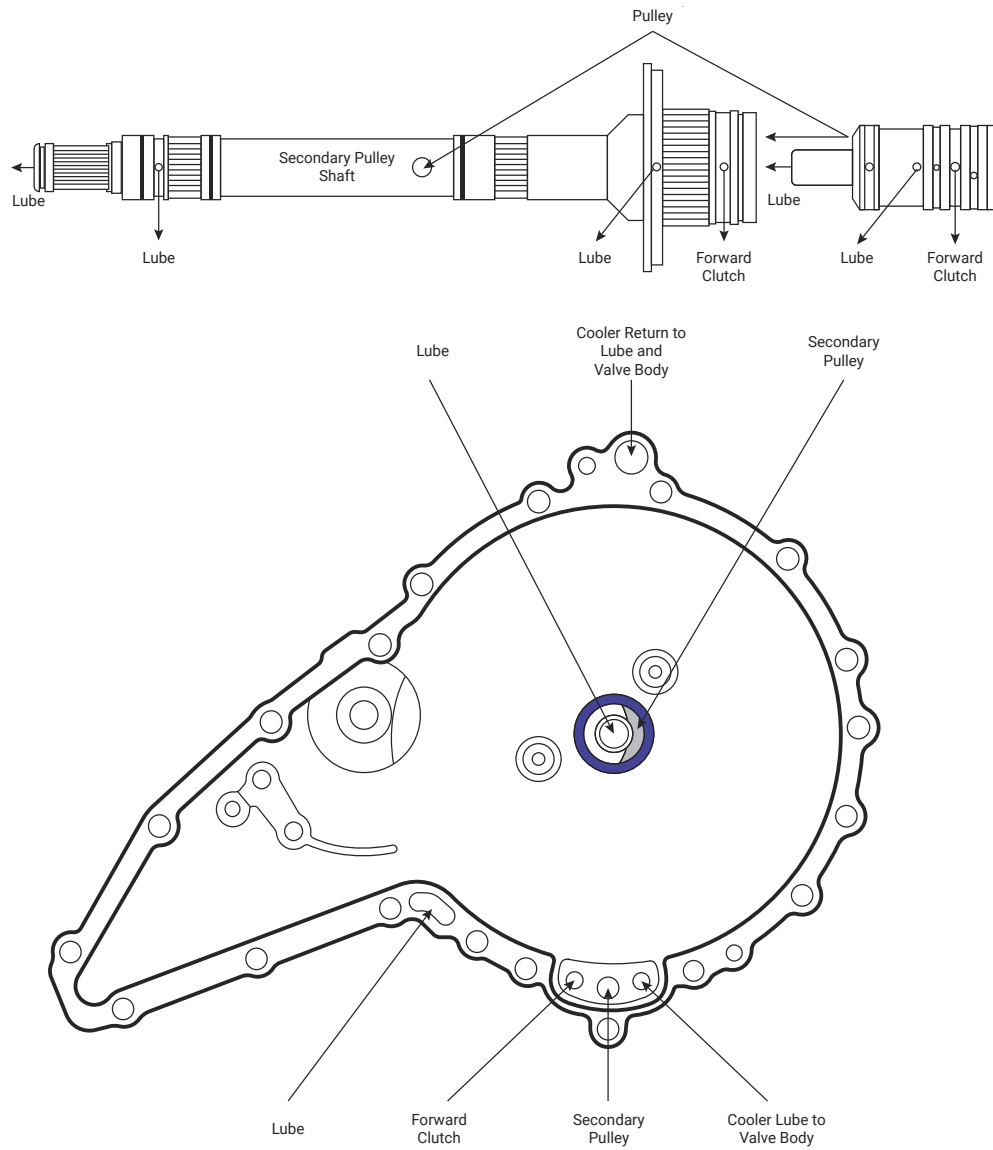

PIN ASSIGNMENT

Pin 1	CAN low
Pin 2	CAN high
Pin 3	Ground 31
Pin 4	Power supply 12V +30

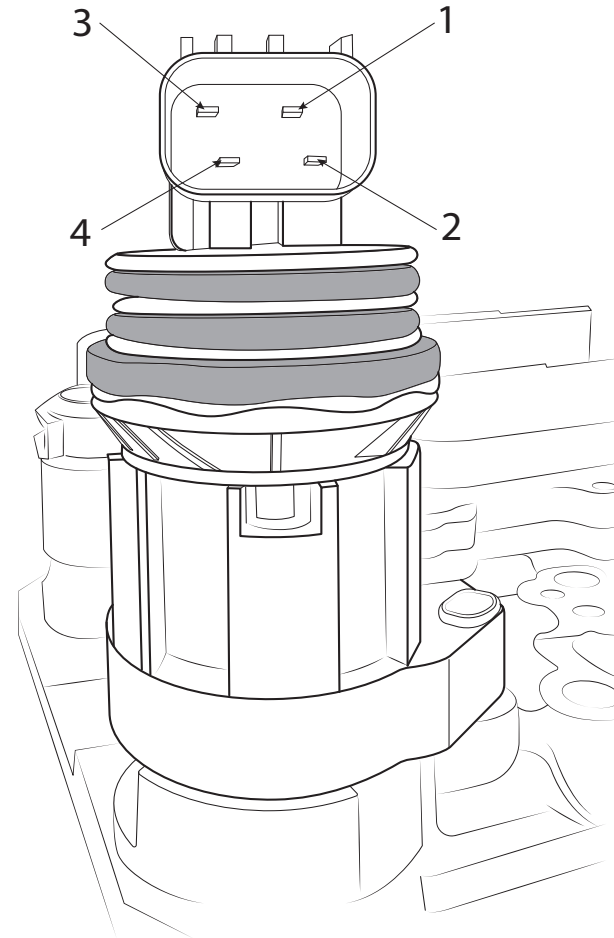

GENERAL OPERATION

The Mercedes-Benz 722.8 is a CVT (Continuously Variable Transmission) with torque converter that is used in both the Mercedes-Benz A (W169) and B (W245) classes.

The CVT

A CVT has two pulleys (one primary and one secondary) that are connected by a metal tension belt. The primary pulley is driven by a torque converter connected to the motor. The secondary pulley drives a planetary gear mechanism with two sets of multi-plate clutches, which in turn drive the differential. The planetary gear mechanism with the multi-plate clutches ensures that you can drive forwards and backwards.

Each pulley consists of two conical halves: one pulley half is mounted statically on the shaft and the other pulley half is hydraulically and axially movable. Because the radius of the pulley contact surfaces is infinitely adjustable with the tension belt, the transmission ratio from the torque converter to the differential is also infinitely variable.

The movable primary pulley half adjusts the gear ratio. As this movable primary pulley half moves towards the static primary pulley half, the secondary adjustable pulley half moves away from the static secondary pulley half and vice versa. The tension (pressure) of the tension belt is regulated by the hydraulically sliding secondary pulley half.

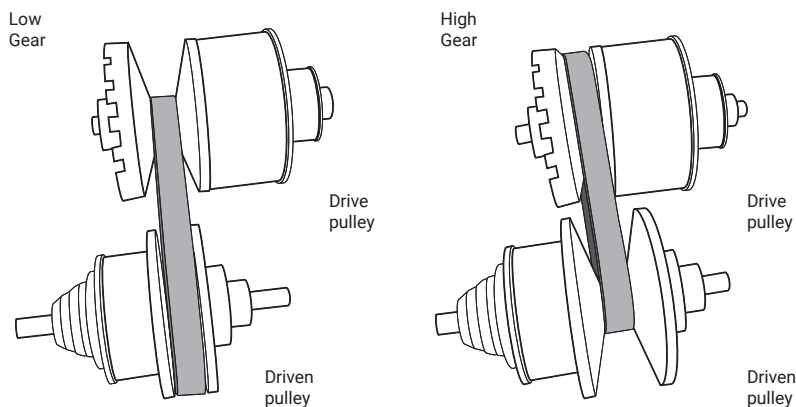

The adjustment of the pulley halves to a lower gear ratio.

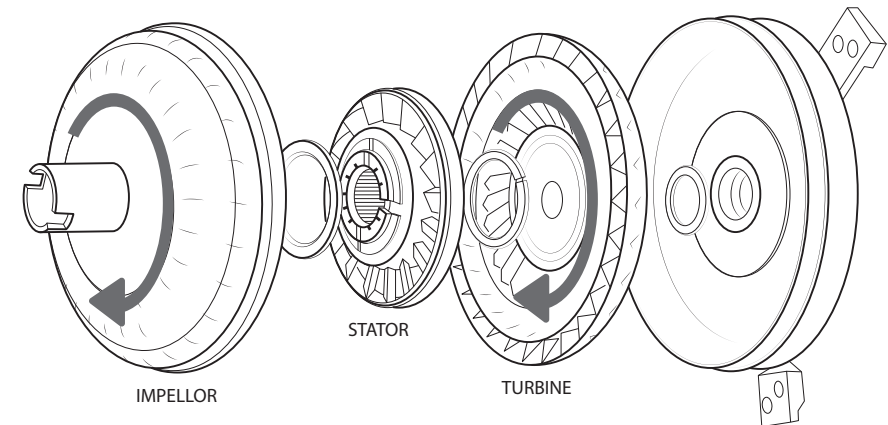

Exploded view torque converter.

The torque converter

The torque converter ensures that the car “creeps” when the engine is idling, a feature that the automatic transmission boxes in the more expensive Mercedes-Benz models also have. A slipping torque converter also increases the torque because of the difference in speed on the engine side and CVT side. This makes starting from a standstill (even with a relatively small atmospheric engine) easy and smooth. In order to eliminate continuous slippage at constant driving speed, a lock-up clutch is placed in the torque converter that can make a fixed connection between the engine and the CVT. This prevents slippage and improves fuel consumption.

A torque converter consists of a pump wheel (impeller), a stator and a turbine, and is filled with liquid. The pump wheel is directly connected to the engine block and will therefore always run at the same speed. As soon as the pump wheel starts to move, the centrifugal force pushes all the liquid to the outside of the enclosed unit. This causes the liquid to flow along the curved blades of the turbine, so that the turbine will eventually rotate in line with the pump wheel. At low speeds, the liquid does not give enough pressure to get the turbine going, but at high speeds, efficiency of up to 90% can be achieved.

The stator is added to the system purely to enhance the liquid effect. The component has a one-way freewheeling function, so that the amplifying effect only occurs when the turbine needs to be brought up to speed.

THE MECHATRONIC IN DETAIL

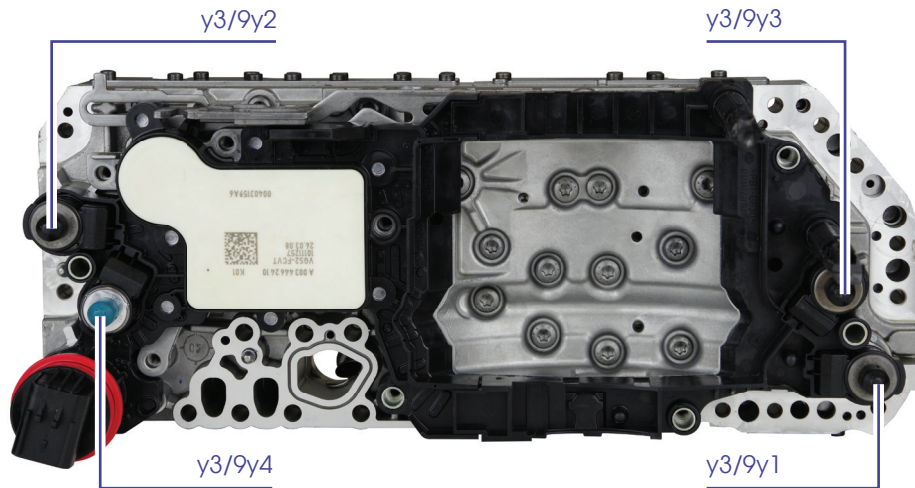

Actuator	Function
Y3/9y1	Control valve for primary pulley
Y3/9y2	Control valve for secondary pulley
Y3/9y3	Control valve for clutch
Y3/9y4	Control valve for lock-up

In order to control the amount of adjustment of the pulleys of the CVT, valves (solenoid valves) and speed sensors are required. The speed of both the driving pulley (engine side) and the speed of the driven pulley (differential side) is measured by 3 speed sensors. It is up to the TCU, the Temic VGS, to determine how much fluid (pressure) the solenoid valves can move to the pulleys to adjust the gear ratio:

Y3/9y1

This valve essentially controls the transmission ratio. At a higher fluid pressure, the movable pulley half of the primary pulley is pressed to the fixed pulley half (via a supply pressure valve), which results in a larger radius of travel of the tension belt.

Y3/9y2

This valve in fact ensures that the tension belt maintains its tension. As soon as a change occurs in the primary pulley, an opposite action follows in the secondary pulley.

To adjust the direction of rotation of the output shaft (and thus to be able to drive backwards) a gearbox with clutch is hidden in one of the pulleys. Valve **Y3/9y3** operates this clutch.

Finally, a valve is also used to operate/control the torque converter: **Y3/9y4**.



Two solenoid valves.

As briefly explained in the previous chapter, a torque converter can never transmit 100% torque without a form of lock-up. Unfortunately, there is always loss. And to eliminate that loss, a lock-up clutch is placed inside the torque converter itself. This literally makes the torque converter a fixed connection between the engine and the CVT, just like a conventional clutch plate and pressure group do in a manual gearbox. This eliminates any kind of slippage.

Pressure loss in the hydraulic circuit

As already briefly mentioned in the error code lists, pressure loss in the hydraulic circuit can result in major problems. We see a number of causes more often:

- › A damaged or missing blue-white O-ring. (see photo below)
- › Cracks in the hydraulic block
- › Contaminated gearbox oil

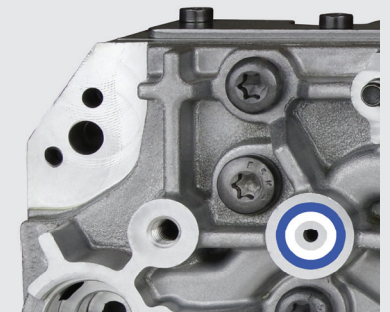

We would strongly advise you to check this carefully **every time** the Mechatronic is assembled or disassembled.

THE TCU IN DETAIL



Sensor	Function
Y3/9n1	Position sensor switching position
Y3/9b3	Speed sensor primary pulley
Y3/9b4	Speed sensor secondary pulley
Y3/9b5	Speed sensor output shaft

The TCU is the brain of the 722.8 CVT. The desired transmission ratio is calculated in the TCU (Transmission Control Unit) based on the following variables: the engine torque, the engine speed, the driving speed, the position of the gear selector lever, the selected shift program and the CAN signals.

Both the speed of the primary pulley (**sensor Y3/9b3**) and the speed of the secondary pulley (**sensor Y3/9b4**) are measured with speed sensors. These sensors use the Hall principle: a principle based on magnetism. This makes it relatively easy to test the function, see also the workshop tip on the right.

A third speed sensor (**Y3/9b5**) measures the speed from the drive shaft to the differential. This also allows any slippage of the tension belt to be detected. In addition to a control function, the TCU also has a checking function.

The last sensor on the TCU is the position sensor of the shift position **Y3/9n1**. The fact that this sensor indicates the values "P", "R", "N" or "D" will not come as a surprise.

**Check the sensor function yourself**

If the car from which the TCU comes is still available, then the sensors of a removed TCU are relatively easy to check by yourself. The only condition is that a diagnostic tool is needed to make live data visible.

Proceed as follows:

1. Connect the connector from the car to the separate TCU
2. Turn on the ignition (power supply)
3. Find the required live data in the reader
4. Use a magnetic screwdriver to move along the sensors several times

The frequency at which the screwdriver passes the sensors now becomes visible as the speed. If this does not happen for one or more sensors, the TCU is defective.

**N.B.:**

With sensor Y3/9n1, it is sufficient to hold the magnetic screwdriver in a certain position near the sensor. The sensor has 4 "fields". Each field displays its own shift position ("P", "R", "N" or "D"). It is also sufficient to leave the TCU mounted on the hydraulic block and to move the original fork (see picture) back and forth.

In addition, always check the sensors for contamination by metal particles. This can also be a thin grey (greasy) layer. It may interfere with the sensor function. If there is any contamination, check the gearbox thoroughly for mechanical wear/damage, as described earlier in "The Mechatronic in detail". Then clean the sensors.

REMOVING THE MECHATRONIC

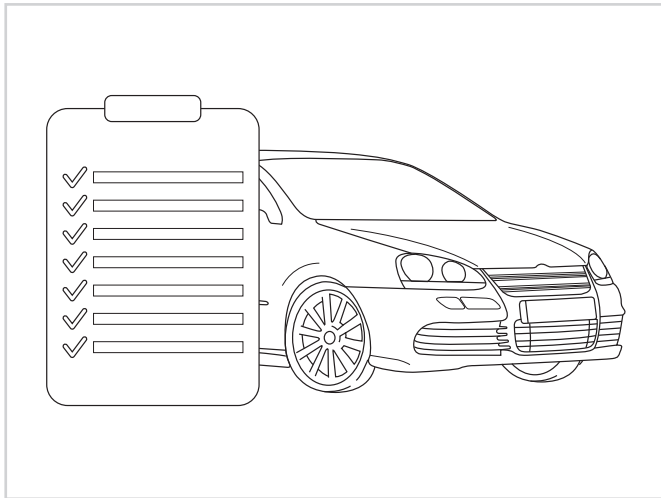

Prior to disassembly

1. Set the selector lever to "P".
2. If a radio with radio code is present: ensure that the radio code is known before disconnecting the battery.
3. Turn off the ignition and disconnect the battery ground lead.

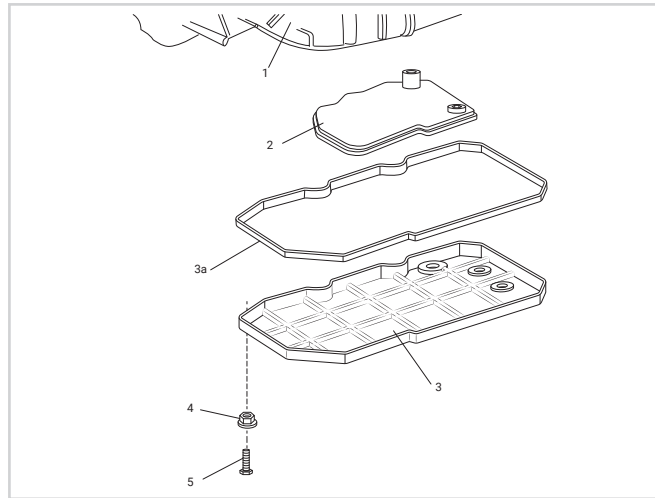

Draining the oil and removing the sump

1. Place a container that can collect at least 7 litres of oil under the gearbox.
2. Remove the plating on the underside of the engine compartment.
3. Remove the drain plug "31" from the CVT sump pan and allow the oil to drain into the container.
4. Loosen the screws "5" and remove the sump pan with gasket.

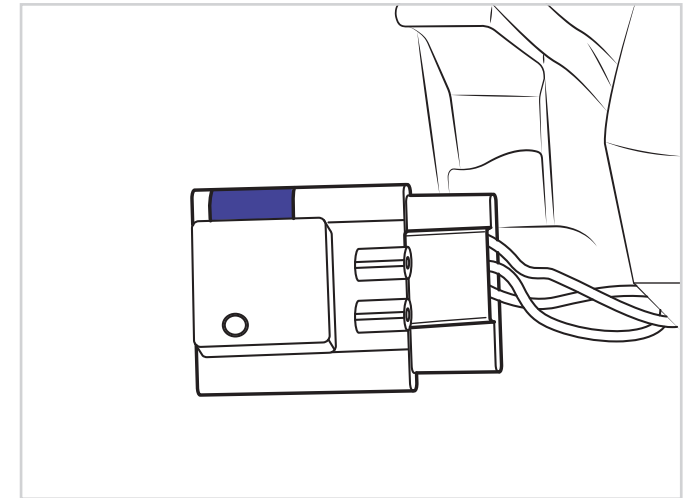

Removing the Mechatronic

1. Set the locking slider "2s" of the plug to the position shown above.
2. Press the lock "2v" and disconnect the plug.

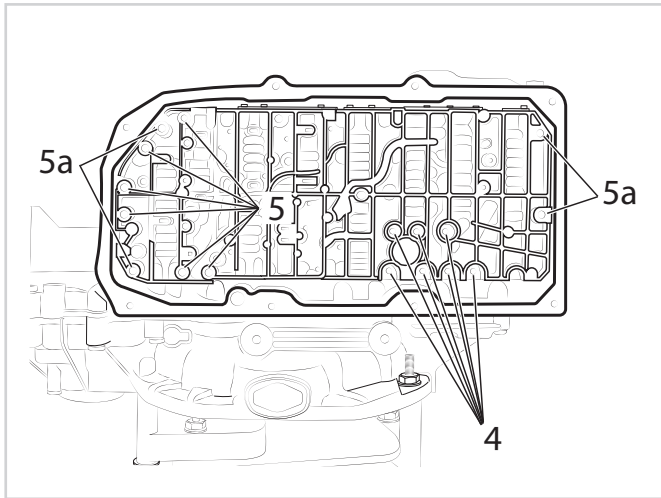

3. Only remove screws "4" and "5" (not "5a"!) from the Mechatronic.
4. First support the Mechatronic and then remove the screws "5a" from the Mechatronic.
5. Now slowly lower the Mechatronic out of the gearbox.

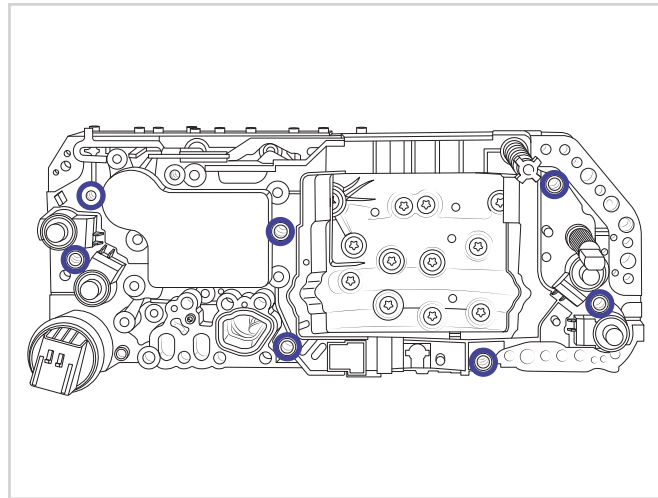

Removing the TCU from the hydro block

1. Remove the marked Torx screws.
2. Remove the 2 leaf springs and the 4 solenoid valves.
3. Pull the TCU straight up and off the hydro block.



ATTENTION:

The sensor arms are vulnerable! Be careful when removing the TCU.

OFFER FOR REMANUFACTURE

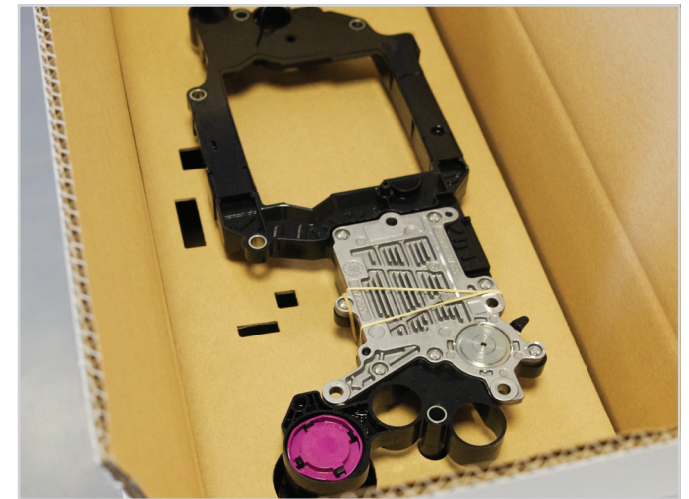
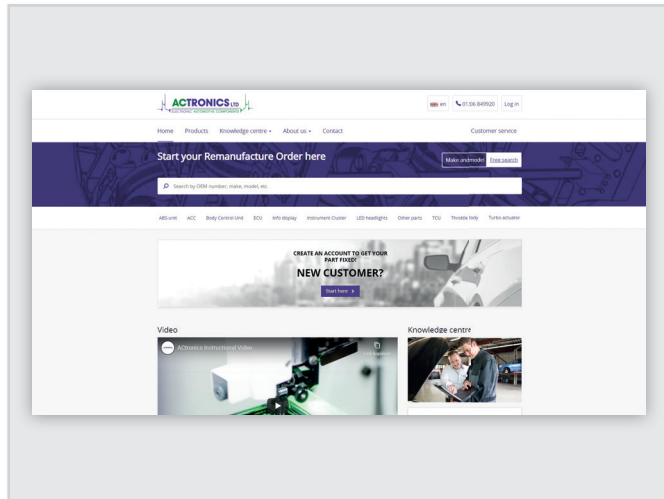

Online aanmelden

- › Go to www.actronics.co.uk and click on "Free search".
- › Then enter "Temic VGS" and the product will immediately appear on the screen.
- › Click on "View product" and follow the dropdown menu.
- › You have now selected the right product.
- › Now click on "Next" and log in to complete the registration.
- › Print the [Remanufacture Order Form](#) after registration.

Shipping

To prevent transport damage, the Temic VGS should always be sent in **without** a hydraulic block. We always ship the TCU back to you in specially developed transport packaging. We do this because the long sensors are extremely fragile. When packing, make sure that the sensor arms are particularly well protected!



ATTENTION:

Enclose the printed Remanufacture Order Form with the product in the transport packaging. This is crucial for identification upon receipt.

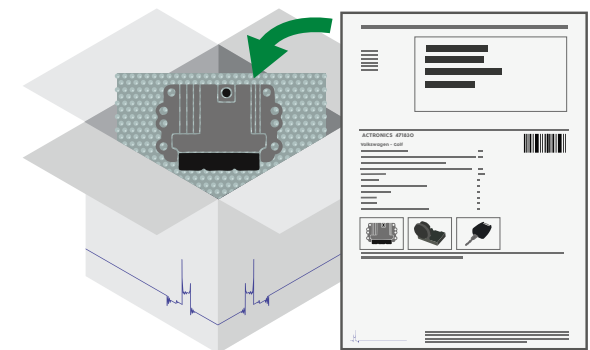

INSTALLING THE MECHATRONIC AFTER REMANUFACTURING

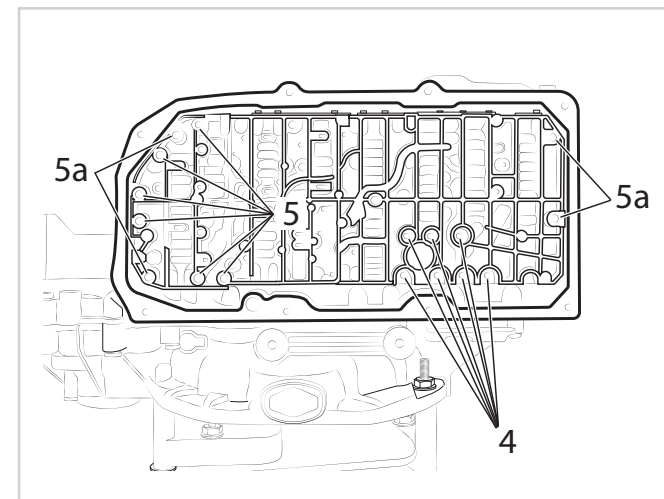
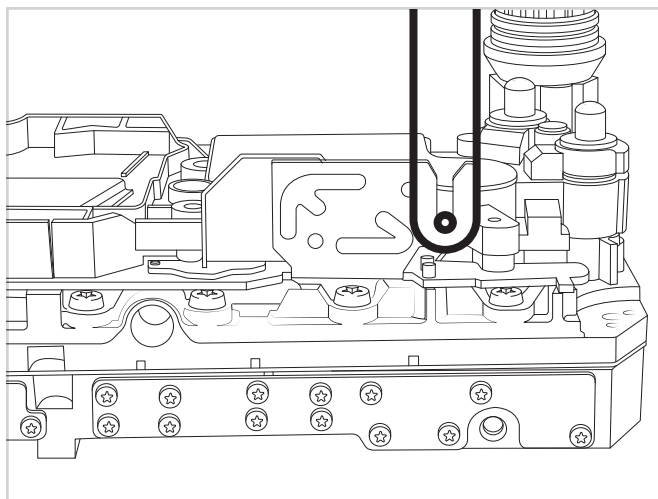
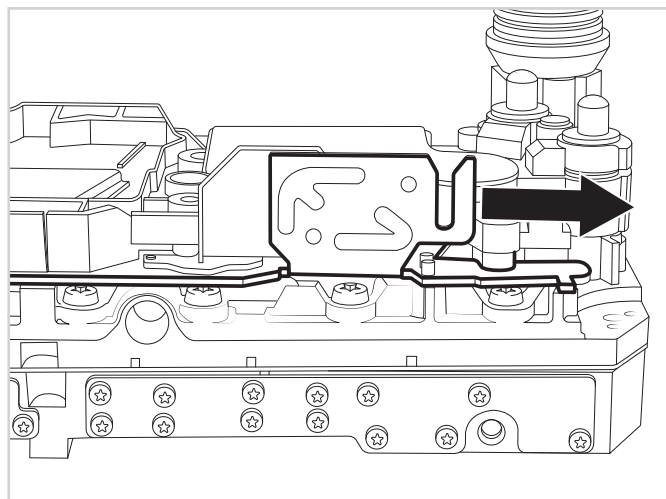
**Replacing**

1. Always check the red sealing rings around the plug before replacing it. Replace if necessary.
2. Always slide the selection slider in the direction of the arrow against the stop.

3. When replacing, make sure that the selection slider engages in the carriage of the locking plate.

Screwing in place

1. Mount the Mechatronic with screws "5a", but do not tighten these screws yet.
2. Mount screws "5", but do not tighten them yet.
3. Mount **new** screws "4", but do not tighten them yet.
4. Tighten screws "5" and "5a" to 4 Nm and then turn them another 90°.
5. Tighten screws "4" without washer to 4 Nm and then turn them another 180°.
6. Tighten screws "4" with washer to 6 Nm.
7. Replace the plug on the Mechatronic and lock it.

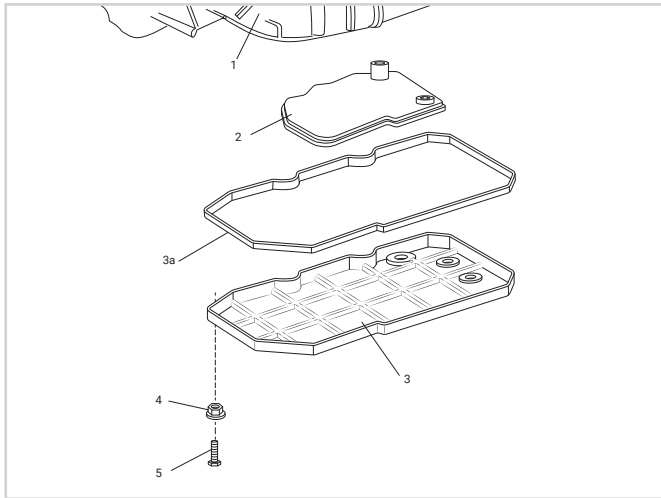

Mounting the sump

1. Mount the sump pan with gasket back on the housing.
2. Tighten the screws "5" to 8 Nm.
3. Fit the drain plug with a **new** washer and tighten to 22 Nm.



ATTENTION:

Up to serial number FZ305061, the sump packaging (if in good condition) can be reused.

From serial number FZ305062 onwards, the sump packaging must be **renewed**.

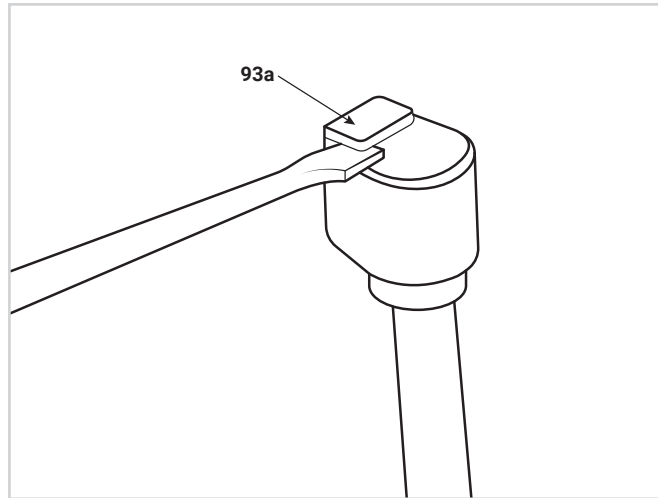

Adding gearbox oil

1. Remove the locking plate "93a" from the "93" oil filler cap and press down the remaining part of the "93b" retainer to remove it.
2. Remove the oil filler cap "93" and fill the gearbox with the prescribed amount of oil.

If it is not clear how much oil needs to be added to the gearbox, take the previously drained amount of oil as a guide.

For refilling, a prescribed funnel (126 589 12 63 00) and filler pipe (140 589 49 63 00) are available.

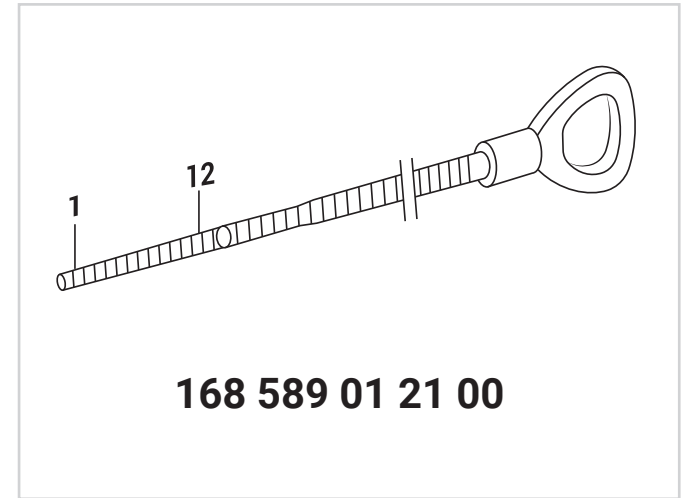

3. Check the oil level while the engine is idling (dipstick 168 589 01 21 00). Use the Star Diagnostic device to be able to read the current gearbox temperature.

The dipstick has 12 level dashes.

The level is correct for the following values:

At 50 °C: Between the 2nd and 4th dash from the bottom

At 80 °C: Between the 5th and 7th dash from the bottom

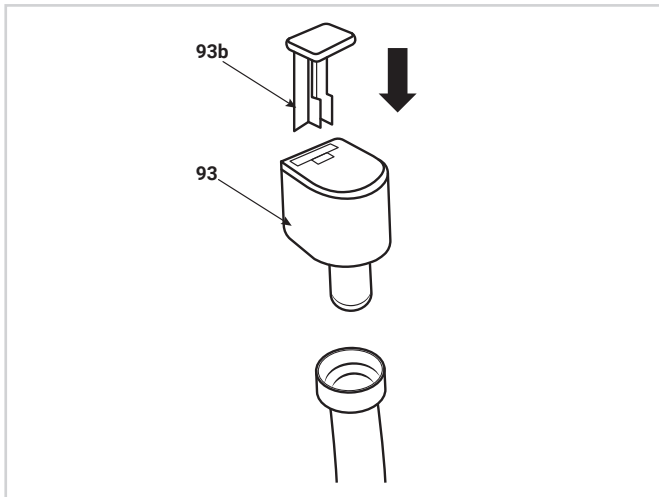
**ATTENTION:**

Filling with too much or too little oil can negatively affect the functioning of the CVT transmission and even lead to damage.

4. Replace the oil filler cap "93".
5. Insert a **new** "93b" latch and make sure it locks securely.
6. Check the CVT transmission for leaks.
7. Reinstall the plating on the underside of the engine compartment.

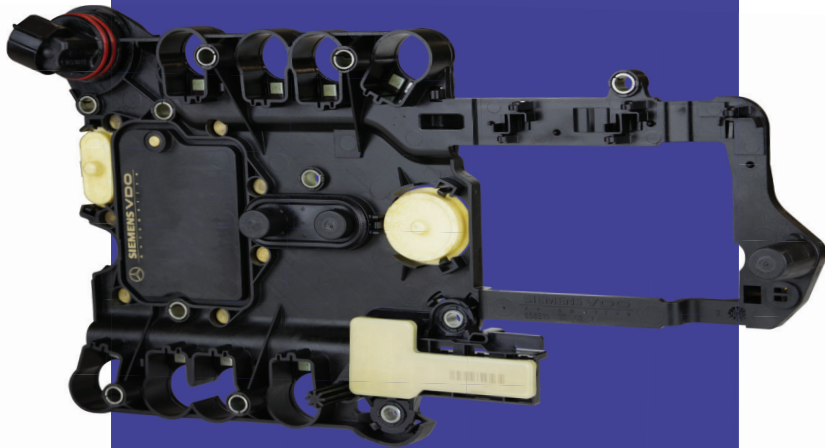

MERCEDES-BENZ 722.9 7G-TRONIC

Experts will probably think immediately of Mercedes-Benz automatic gearboxes when they hear the term '7G-Tronic'. And rightly so, because this gearbox was the first 7-speed automatic ever for passenger cars. The gearbox was introduced in 2003 on all Mercedes models with 8 cylinders.



MERCEDES-BENZ M-CLASS W164 2006-2012

Mercedes-Benz 722.9 - 7G-tronic



MERCEDES-BENZ M-CLASS W166 2011-2015

Mercedes-Benz 722.9 - 7G-tronic



MERCEDES-BENZ SLK W171, R171 2004-2011

Mercedes-Benz 722.9 - 7G-tronic



MERCEDES-BENZ C-CLASS W203, CL203, S203 2000-2007

Mercedes-Benz 722.9 - 7G-tronic



MERCEDES-BENZ C-CLASS W204, C204, S204 2007-2014

Mercedes-Benz 722.9 - 7G-tronic



MERCEDES-BENZ CLK W209, A209, C209 2002-2009

Mercedes-Benz 722.9 - 7G-tronic



MERCEDES-BENZ E-CLASS W211, S211 2002-2008

Mercedes-Benz 722.9 - 7G-tronic



MERCEDES-BENZ E-CLASS W212 S212, C207, A207 2009-2016

Mercedes-Benz 722.9 - 7G-tronic



MERCEDES-BENZ CL-CLASS W215 1998-2005

Mercedes-Benz 722.9 - 7G-tronic



MERCEDES-BENZ CL-CLASS W216 2006-2013

Mercedes-Benz 722.9 - 7G-tronic



MERCEDES-BENZ CLS W219, C219 2004-2010

Mercedes-Benz 722.9 - 7G-tronic



MERCEDES-BENZ S-CLASS W220 1998-2005

Mercedes-Benz 722.9 - 7G-tronic

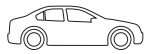

MERCEDES-BENZ S-CLASS W221 2005-2013

Mercedes-Benz 722.9 - 7G-tronic

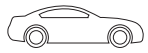

MERCEDES-BENZ SL W230, R230 2001-2012

Mercedes-Benz 722.9 - 7G-tronic

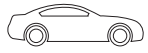

MERCEDES-BENZ SL W231, R231 2012-2019

Mercedes-Benz 722.9 - 7G-tronic



MERCEDES-BENZ R-CLASS W251, V251 2006-2014

Mercedes-Benz 722.9 - 7G-tronic



MERCEDES-BENZ VITO / V-CLASS W447 2015-2019

Mercedes-Benz 722.9 - 7G-tronic

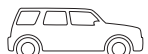

MERCEDES-BENZ G-CLASS W461, W463 1979-2019

Mercedes-Benz 722.9 - 7G-tronic



MERCEDES-BENZ GL-CLASS X164 2006-2012

Mercedes-Benz 722.9 - 7G-tronic

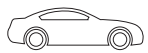

MERCEDES-BENZ CL-CLASS W215 1998-2005

Mercedes-Benz 722.9 - 7G-tronic

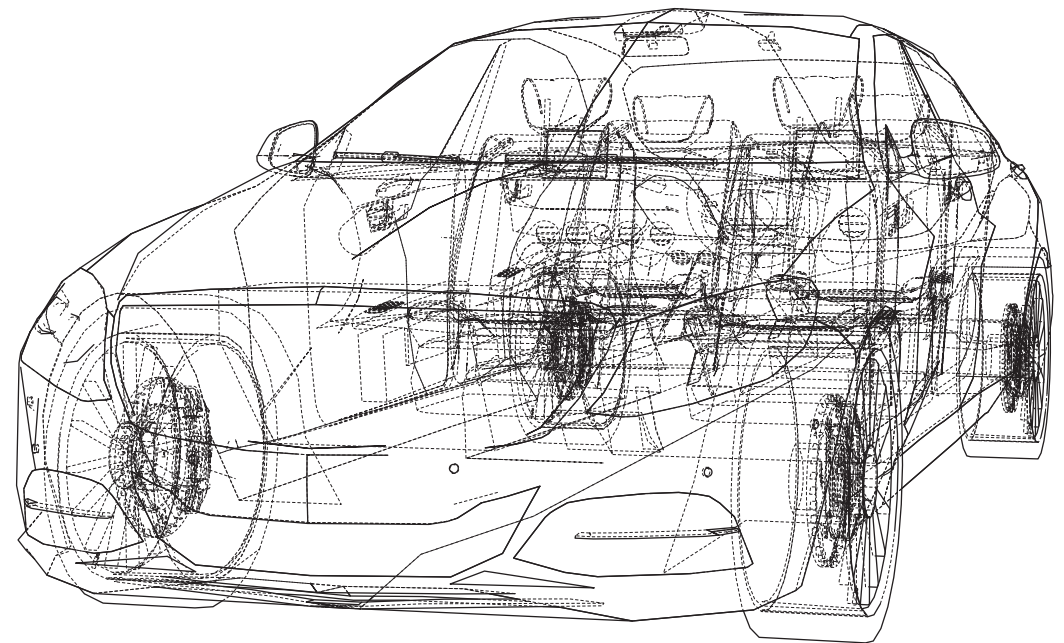

KNOWN COMPLAINTS

- › Continuous gear shifting between gears
- › Clutch slipping
- › Loss of propulsion while driving
- › Not wanting to start and/or drive away

CAN BE REMANUFACTURED

OBD II	Description
P0705	Component Y3/8s1 selection range sensor is defective
P0717	The signal from component (sensor) Y3/8n1 is not available
P0718	Component (sensor) Y3/8n1 is defective
P0720	Output speed sensor circuit malfunction
P0721	The transmission output speed signal is implausible, when compared to the wheel RPM signal
P0722	Output speed sensor no signal
P0723	Output speed sensor is defective
P2200	The signal from component (sensor) Y3/8n2 is not available
P2201	Component (sensor) Y3/8n2 is defective
P2204	The signal from component (sensor) Y3/8n1 is not available
P2205	Component (sensor) Y3/8n1 is defective
P2206	The signal from component (sensor) Y3/8n3 is not available
P2207	The value of component Y3/8n3 is implausible
P2550	Component (sensor) Y3/8n3 is defective
P2716	Pressure control solenoid electrical
P2767	The signal from component (sensor) Y3/8n2 is not available
P2768	Component (sensor) Y3/8n2 is defective



It is rare, but in theory these sensor problems can also be caused by a deviation at the magnetic sensor rings. Think of abnormalities such as damage to and/or iron grinding of the ring. So it is always a good idea to check them properly.

REMANUFACTURE MAY BE POSSIBLE ADDITIONAL DIAGNOSIS REQUIRED

OBD II	Description
P0894	Transmission component slipping
P2502	Implausible gear or transmission slipping
P2505	Gear not engaged or transmission slipping
P2711	Unexpected mechanical gear disengagement

These error codes normally appear as soon as the software detects a problem through the signals from the speed sensors. If a speed sensor is not working properly, these error codes can be activated incorrectly. If these error codes appear in combination with the error codes from the previous table, have the TCU remanufactured first and delete all error codes after assembly. There is a good chance that these error codes will stop appearing after that.

OBD II	Description
P2806	Component (sensor) Y3/8s1 is not learned

If error code 2806 is active, the diagnostic device will not display the switching positions. The TCU will have to be re-taught. If the fault persists, the switching position sensor is defective. We can replace these during remanufacture.

If in doubt, please contact our Customer Service.

Telephone: 01206 849920

CANNOT BE REMANUFACTURED

OBD II	Description
P2783	Clutch actuator temperature too high

When the car is in limp mode: This error code indicates (extreme) wear of the lock-up clutch. Assuming that the temperature measurement is correct: check whether the magnets in the sump pan are full of (iron) swarf. If this is indeed the case, then it can be assumed that the lock-up clutch is really damaged. It is advisable to replace the entire gearbox including the torque converter, because the iron swarf has now spread throughout the entire transmission.

In addition, the oil cooler needs to be flushed. However, if the oil cooler is equipped with a thermostat, rinsing is not possible. The oil cooler must therefore be replaced.

OBD II	Description
P0748	Pressure control solenoid "A" electrical
P0778	Pressure control solenoid "B" electrical
P0798	Pressure control solenoid "C" electrical
P2716	Pressure control solenoid "D" electrical
P2725	Pressure control solenoid "E" electrical
P2734	Pressure control solenoid "F" electrical
P2759	Torque converter lock-up clutch control solenoid
P2810	Pressure control solenoid "G" electrical

When the car is in limp mode: The above error codes may indicate one or more defective solenoid valves, but the problem may also be somewhere else. More information can be found in "The Mechatronic in detail".

PIN ASSIGNMENT

Pin 1	CAN high
Pin 2	CAN low
Pin 3	Diagnostic line
Pin 4	Power supply 12V +30
Pin 5	Ground 31

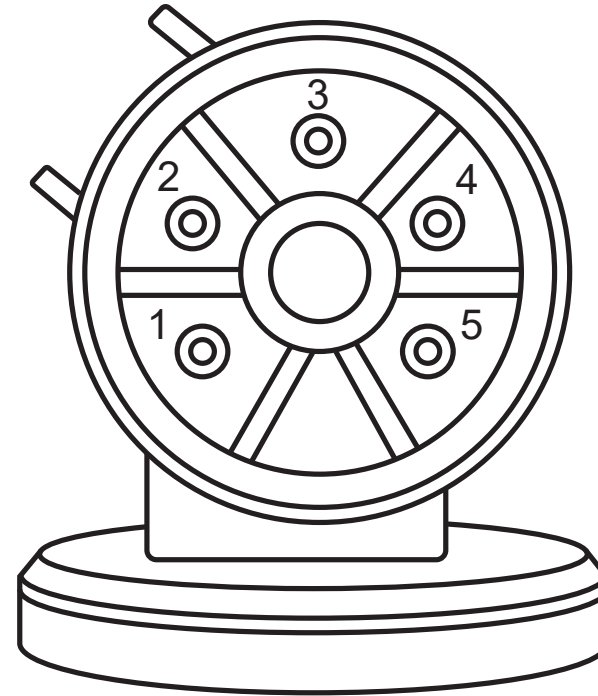

GENERAL OPERATION

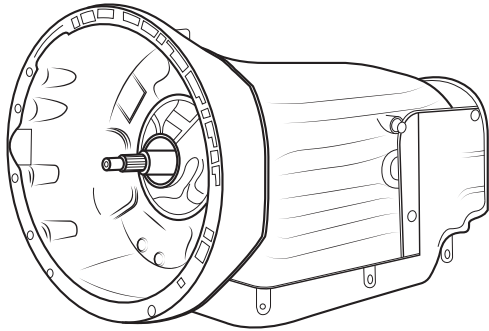

The 7G-Tronic was introduced on 5 different Mercedes-Benz models with V8: E500, S430, S500, CL500 and SL500. The gearbox was subsequently also used on certain 6-cylinder diesels such as, for example, cars with the 320 CDI engine. However, the cars with V12 engines (S600, S65 AMG) carried on using the older 5G-Tronic, because this gearbox could handle a torque up to 1079 Nm. The 7G-Tronic has a limit of 'only' 735 Nm, which is really not enough for the more powerful V12 engines.



Did you know?

The gearbox body is made of magnesium to save weight. Mercedes-Benz was the first manufacturer ever to do this.

The gearbox is able to skip gears when shifting down. The system also features a lock-up: a permanent clutch behind the fluid clutch that ensures 100% transmission when needed. This improves acceleration. Wondering exactly how such a torque converter works? Take a look at "Mercedes-Benz 722.8: Temic IGS" in the chapter "General operation".

The gear system of the 7G-Tronic consists of three planetary gear systems and one Ravigneaux gear system: simply explained a planetary gear system on a planetary gear system. This dual function makes many more different gearbox ratios possible, which means that 9 gears can still fit inside a relatively compact gearbox (7 forward, 2 reverse).



An interesting detail:

The 7G-Tronic has 2 reverse gears with different ratios. In comfort mode, the 7G-Tronic drives both forwards and backwards in 2nd gear in order to maintain more traction and to be able to drive off more gently in, for example, winter conditions.

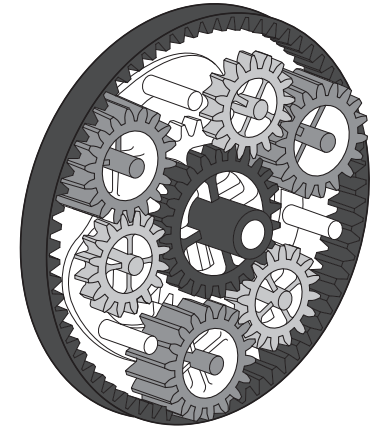

Behaviour in case of emergency

Mercedes-Benz has deliberately given the emergency braking system several modes in order to make driving as pleasant as possible:

1. The instant a solenoid valve breaks down, only the corresponding gears are blocked. The system is able to skip gears in order to be able to function more or less normally.
2. If a gear cannot be engaged due to a hydraulic problem, the current gear will remain selected until a gear can be skipped.
3. Even if the TCU (the computer in the gearbox) fails completely while driving, the car remains driveable: all solenoid valves are switched off. This means that pressure is maintained via the solenoids that are open in 0 position (normally open solenoids). The gearbox therefore remains in 6th gear while driving. When shifting to "P", the fluid pressure of clutch K2 is diverted in such a way that it is possible to drive in 2nd gear in "D" and in "R". This principle may be easier to understand with the help of the schematics from page 39.

THE MECHATRONIC IN DETAIL

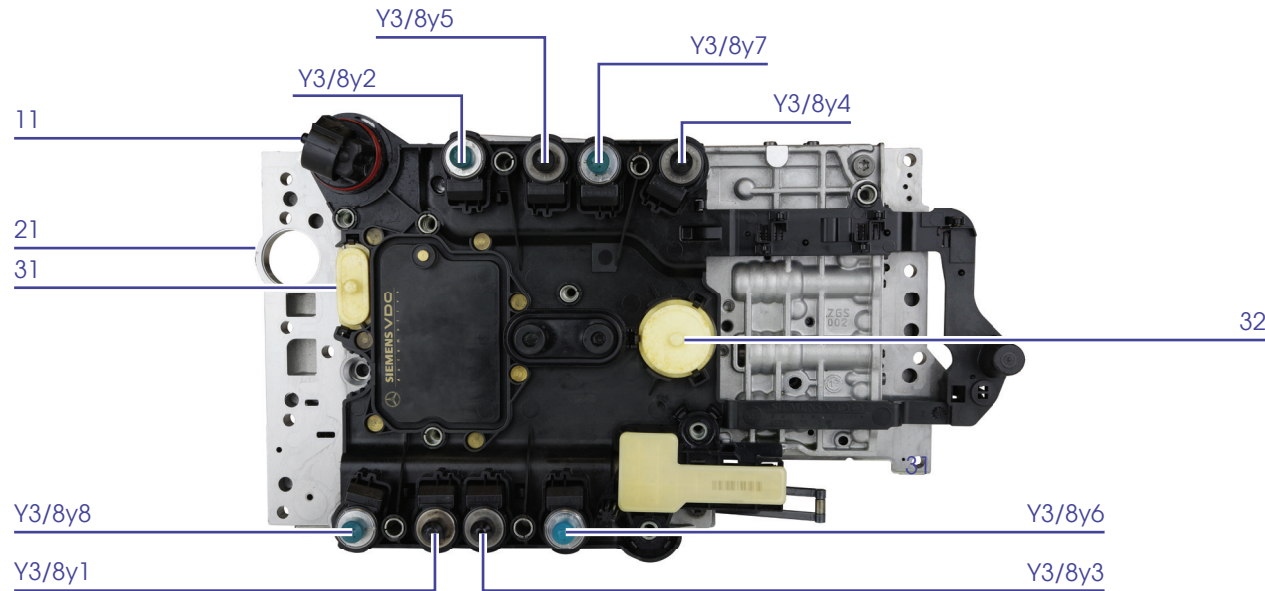

Part no.	Function
11	Plug
21	Hydraulic block / valve body, consisting of 2 parts and a partition panel
31	Oil level float 1
32	Oil level float 2
Y3/8y1	Control valve for general operating pressure
Y3/8y2	Clutch control valve K1
Y3/8y3	Clutch control valve K2
Y3/8y4	Clutch control valve K3
Y3/8y5	Brake control valve B1
Y3/8y6	Brake control valve B2
Y3/8y7	Brake control valve B3
Y3/8y8	Lock-up clutch control valve

The Mechatronic consists of a TCU (Transmission Control Unit), a 3-part hydraulic block (valvebody) and several control valves (solenoid valves). The hydraulic block acts as a labyrinth, allowing the fluid pressure to flow directly to the components to be controlled. The control valves control these fluid flows. Normal open solenoids and normally closed solenoids are used to maintain limited functionality in the event of a malfunction.

The diagram on the next page shows which control valves must be activated to select a particular gear. This also indicates that only one control valve has to be activated each time there is a direct changeover.

WARNING: COMPLAINTS ABOUT FLUID PRESSURE

Error codes involving fluid pressure often point to a defective control valve. Unfortunately it is not possible to extensively test the solenoid valves using diagnostic software. However, by changing the position of the solenoid valves, it is easy to test whether they are actually defective because the error code should change to an error code that belongs to the new position.

If the control valve is defective, pay close attention to the type of valve required: the normally closed solenoids have a **blue-green cap** and the normally open solenoids a **black cap**. The plug is different, so fortunately it is not possible to install it incorrectly.

However, the cause of fluid pressure complaints often lies elsewhere. Pressure loss can also occur, for example, when seals no longer work or when cracks appear in the hydraulic block. Unfortunately this happens sometimes, so check this carefully!

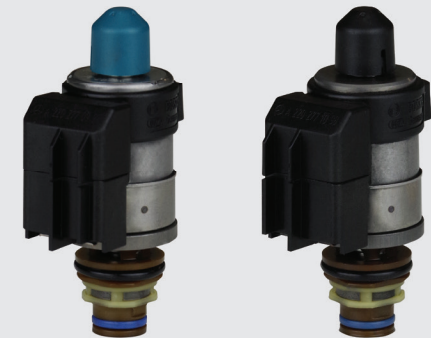

Switching diagram for control valves

Valve for:	K1	K2	K3	B1	B2	B3	BR
1st gear			*		*	*	
2nd gear			*	*	*		
3rd gear	*		*		*		
4th gear	*	*			*		
5th gear	*	*	*				
6th gear		*	*	*			
7th gear			*	*		*	
Neutral			*			*	
1st reverse gear			*			*	*
2nd reverse gear			*	*			*



Tip for locating unusual switching complaints:

The switching diagram can, of course, also be used for diagnostic purposes.

An example:

A car with a 722.9 gearbox does not want to shift up any further than 2nd gear. 3rd gear cannot be engaged and the vehicle shoots into limp mode. The diagram shows that multi-plate clutch K1 should be officially enabled by control valve Y3/8y2. In the absence of error codes that specifically indicate a defective TCU or control valve, it can in this case be concluded that multi-plate clutch K1 is very likely to be defective.

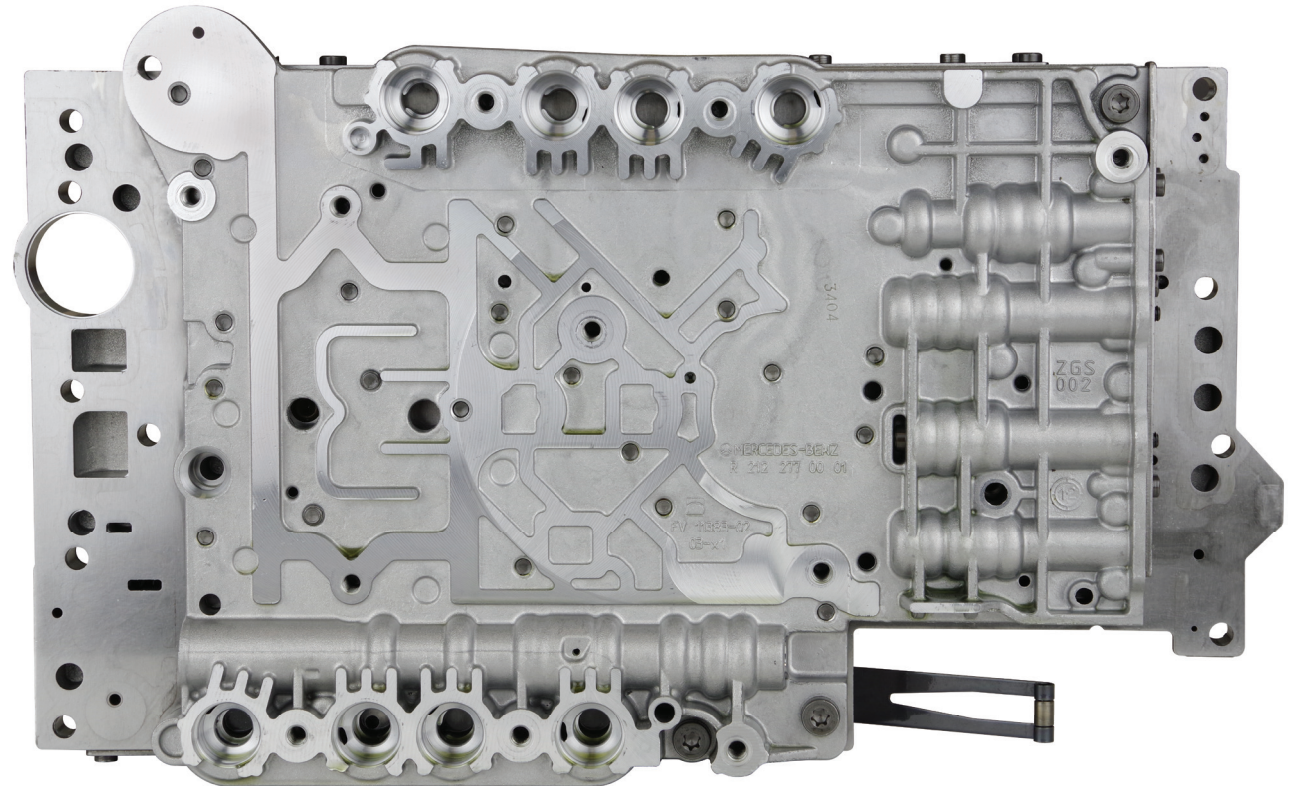

The valve body: a labyrinth of fluid lines, consisting of 2 metal housings and a dividing plate.

THE TCU IN DETAIL

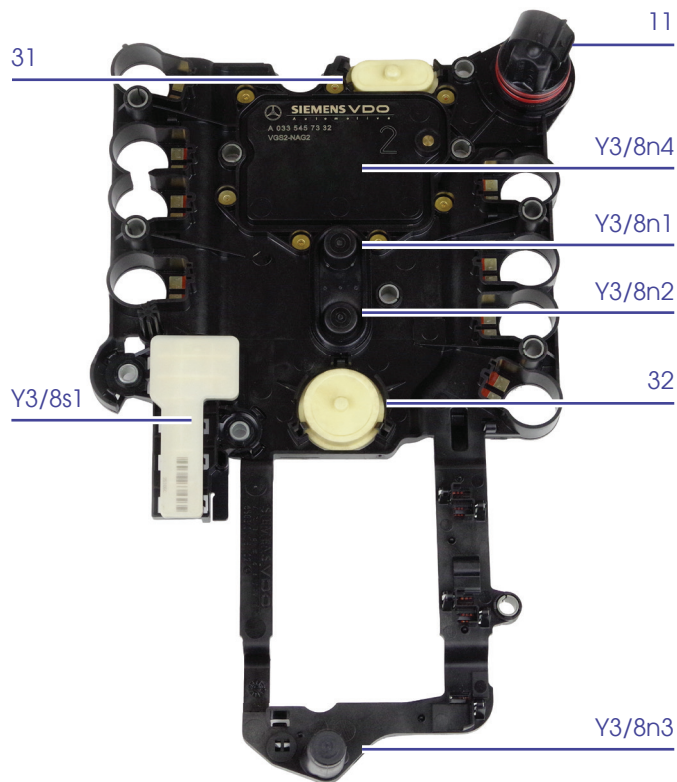

At the moment of writing, there are 4 generations of 7G-tronic. The version number is indicated by a large number on control module Y3/8n4.

The first 2 generations in particular are known for their problems with the speed sensors. From generation 3 onwards, this has been considerably improved. Sensor defects therefore occur only sporadically in generation 3 and 4.

The sensors use the Hall principle: a variation in a magnetic field is converted into an electrical signal. In order to apply this principle in a usable way, various rotating parts in the gearbox with teeth and/or notches are used. In theory, a signal could also be disturbed by a deviation of these notches. In this type of gearbox, however, this is rare: in 99% of cases, a sensor really does fail (sporadically).

Instant replacement is not possible

A Mechatronic from a donor car cannot just be placed in another car. The unit will have to be virginised first (= remove all codes, just like a new unused part). Then carry out "Commissioning after repair N15/3". Part of this "Commissioning after repair N15/3" is the SCN coding. This coding can be obtained by reading the original TCU. If this is not possible, it can be requested via a Mercedes-Benz online platform. The SCN coding for the car is only issued once Mercedes-Benz has approved the conditions.

Virginising is something that ACtronics can also do. That is why we also have the possibility to offer a replacement part, if necessary. "Commissioning after repair N15/3" still needs to be carried out, but the TCU is usable in any case.

Sensor	Function
Y3/8n1	Input shaft speed sensor
Y3/8n2	Central speed sensor
Y3/8n3	Output shaft speed sensor
Y3/8n4	Control module
Y3/8s1	Position sensor switching position
31	Oil level float 1
32	Oil level float 2
11	Plug



Workshop tip:

Check the sensor function yourself

If the car from which the TCU comes is still available, then the sensors of a removed TCU are relatively easy to check by yourself. The only condition is that a diagnostic tool is needed to make live data visible.

Proceed as follows:

1. Connect the connector from the car to the separate TCU
2. Turn on the ignition (power supply)
3. Find the required live data in the reader
4. Use a (magnetic) screwdriver to move along the sensors several times

The frequency at which the screwdriver passes the sensors now becomes visible as the speed.

N.B.1:

With sensor Y3/8s1, it is sufficient to hold the magnetic screwdriver in a certain position near the sensor. The sensor has 4 "fields". Each field displays its own shift position ("P", "R", "N" or "D").

N.B.2:

Speed sensors Y3/8N1 and Y3/8N2 respond to a magnet. Speed sensor Y3/8N3 reacts to metal.



REMOVING THE MECHATRONIC

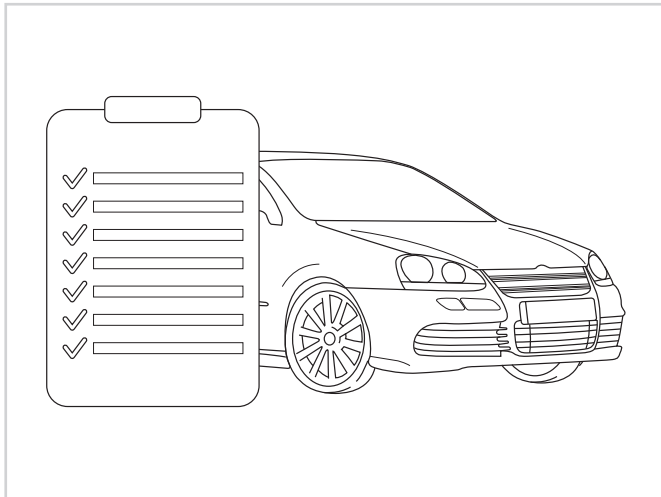

Prior to disassembly

1. Set the selector lever to "P".
2. If a radio with radio code is present: ensure that the radio code is known before disconnecting the battery.
3. Turn off the ignition and disconnect the battery ground lead.

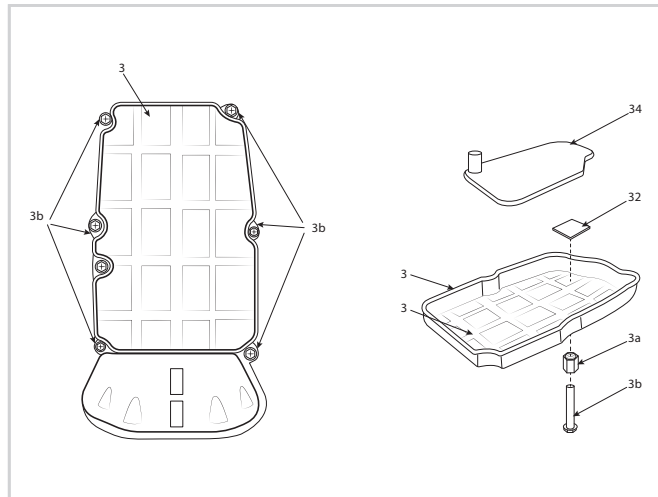

Draining the oil and removing the sump

1. Place a container that can collect at least 7 litres of oil under the gearbox.
2. Remove the plating on the underside of the engine compartment.
3. Unscrew the drain plug from the sump "3" and drain the oil into the container.
4. Loosen the screws "3b" and remove the sump pan with gasket.
5. Remove the filter "34": you can pull it straight down out of its seat.
6. Let the oil that flows out afterwards also run into the container.

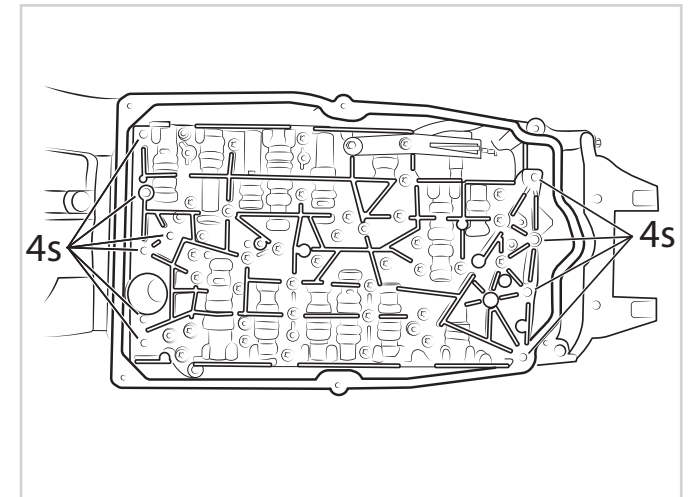

Removing the Mechatronic

1. Remove the heat shield that is placed over the TCU plug.
2. Unplug the power cord.
3. Support the Mechatronic and loosen the screws "4s".
4. The Mechatronic can now be removed by pulling it straight down and off the gearbox.



ATTENTION:

If the Mechatronic remains stuck after undoing the screws, be careful not to pry it loose: the sealing surface on which the gasket is located is easily damaged!

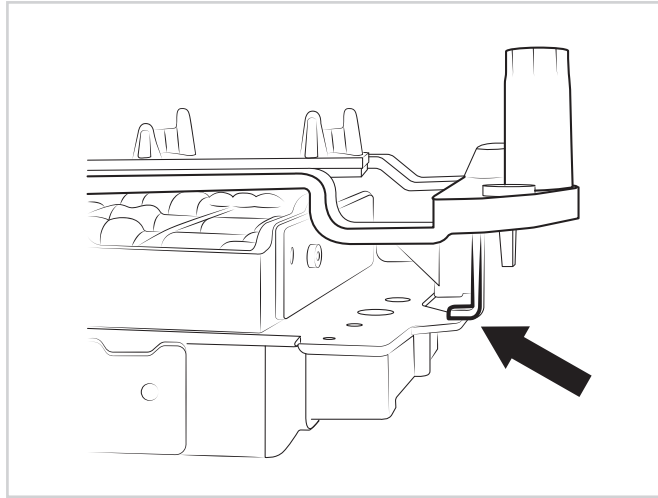
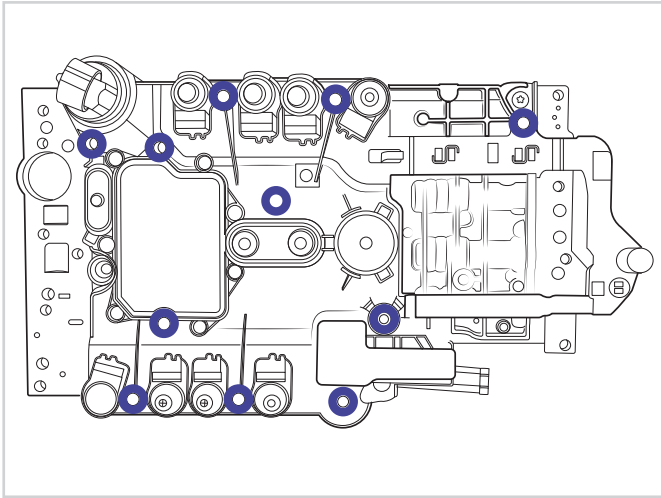

Removing the TCU from the hydraulic block

1. Remove the marked Torx screws.
2. Remove all leaf springs.
3. Remove all solenoid valves.
4. Release the TCU's hook from the hydraulic block (see arrow).
5. Remove the TCU from the hydraulic block

OFFER FOR REMANUFACTURE

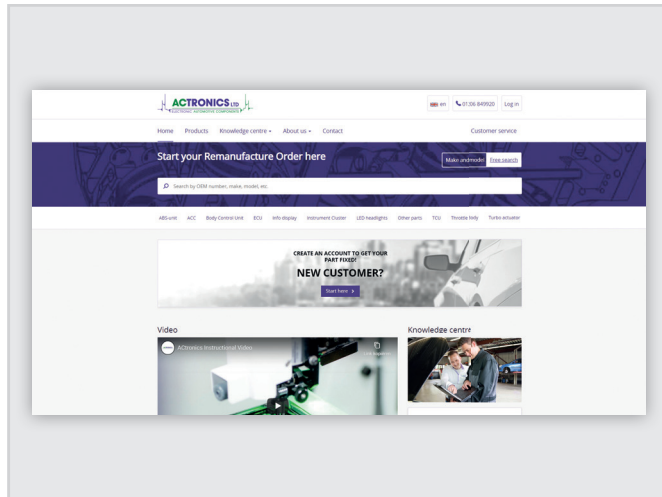

Sign up online

- › Go to www.actronics.co.uk and click on "Free search".
- › Then enter "7G" and the product will immediately appear on the screen.
- › Click on "View product" and follow the dropdown menu.
- › You have now selected the right product.
- › Now click on "Next" and log in to complete the registration.
- › Print the [Remanufacture Order Form](#) after registration.

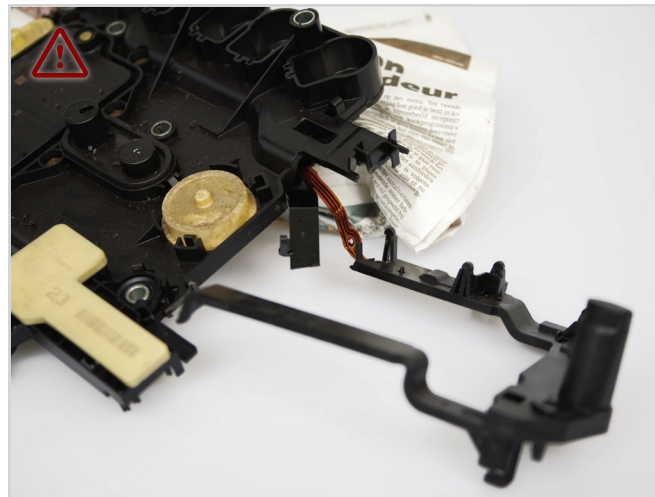

Shipping

To prevent transport damage, the 7G tronic should always be sent in **without a hydraulic block**. We always ship the TCU back to you in specially developed transport packaging. We do this because the plastic of the TCU is extremely fragile. When packing, make sure that the TCU is particularly well protected!

**IMPORTANT:**

Enclose the printed Remanufacture Order Form with the product in the transport packaging. This is crucial for identification upon receipt.

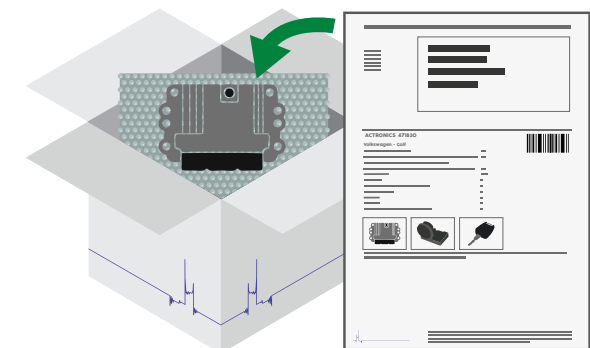

INSTALLING THE MECHATRONIC AFTER REMANUFACTURING

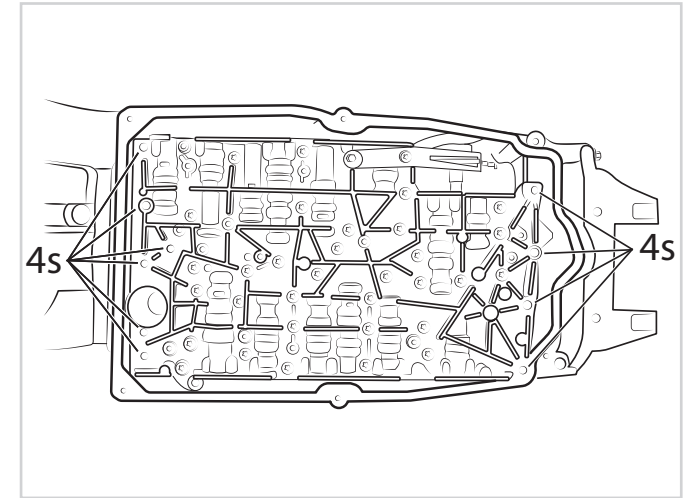
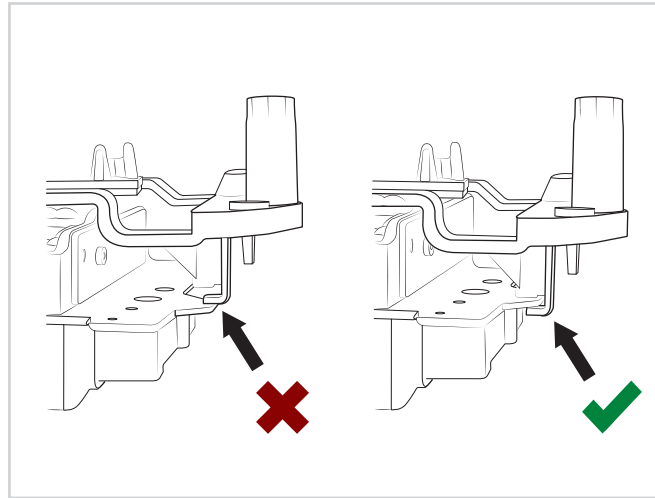
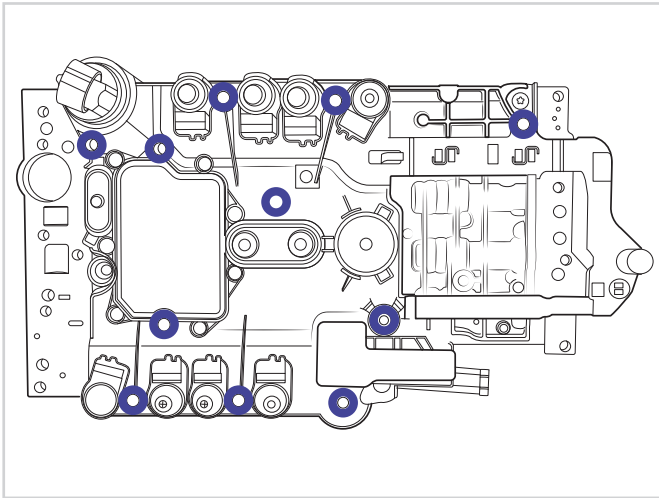

Mounting the TCU on the hydraulic block

1. Place the TCU on the hydraulic block: click the hook around the hydraulic block (like the 2nd picture on this page).
2. Place all solenoid valves.
3. Place the leaf springs: the convex side of the leaf spring should point upwards.
4. Mount the Torx screws in the specified locations. Tightening torque: 5 Nm.



ATTENTION:

If the hook is not correctly clicked onto the hydraulic block, speed sensor Y3/8n3 will not function properly! After a while, error codes P0721 and P0722 will appear and the gearbox will go into limp mode. The photo above shows how the hook is mounted correctly.

Installing the Mechatronic

1. Reinstall the Mechatronic in the gearbox as shown.
2. Tighten the screws "4s" to 4 Nm and then turn them another 90°.
3. Reconnect the plug to the Mechatronic.
4. Mount the heat shield over the plug. Tightening torque for screws: 9 Nm.
5. Attach the battery ground wire.

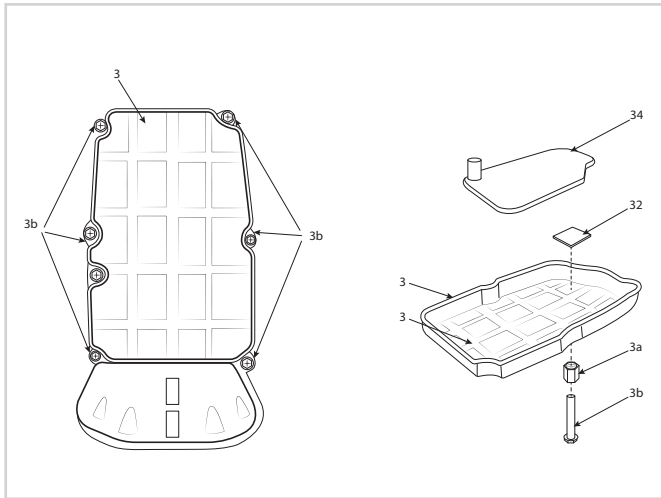

Mounting the sump

1. Install a **new** filter "34".
2. Install a **new** gasket "33" on the sump pan "3".
3. Place the sump pan "3" with gasket "33": tighten the screws to 4 Nm and then turn these another 180°.

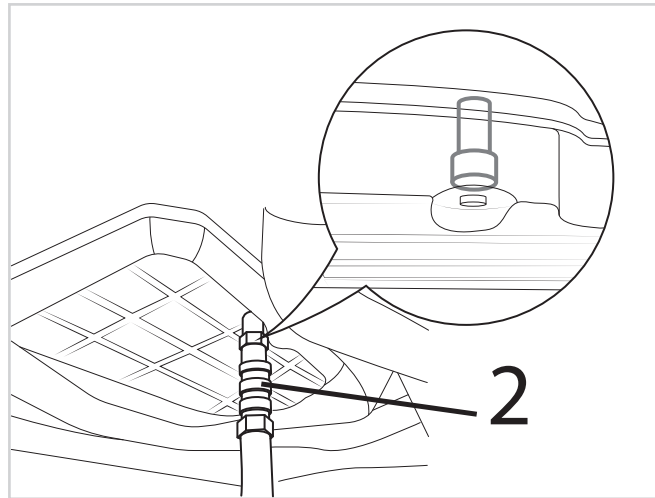

Adding gearbox oil

1. Mount the adapter "2" (special tool) in the hole of the sump pan.
2. Connect the oil filling device to the adapter "2".
3. Pump 6 litres of gearbox oil into the gearbox.
4. Start the engine.
5. When the engine is running, check the temperature of the gearbox oil. Use the Star Diagnostic device for this purpose.
6. Bring the gearbox oil to the correct temperature. To do this, keep the engine speed at 2500 rpm with the gearbox in position "P":

Correct temperatures for filling the gearbox with oil:

Cars with extra oil cooler for the gearbox: **90° C.**

Cars without additional oil cooler, but with a white overflow "1": **45° C.**

Cars without additional oil cooler, but with a black overflow "1": **35° C.**

7. Turn off the engine and let the gearbox oil cool down.
8. Now start the engine again and leave the gearbox in the "P" position.
9. Pump an additional 2 litres of gearbox oil into the gearbox (4 litres for types that also require refilling of the torque converter).
10. Press and hold the brake pedal and change to "P", "N", "R" and "D" several times.
11. Bring the gearbox oil to the correct temperature again and leave the engine running.
12. Place a container for oil under the gearbox.

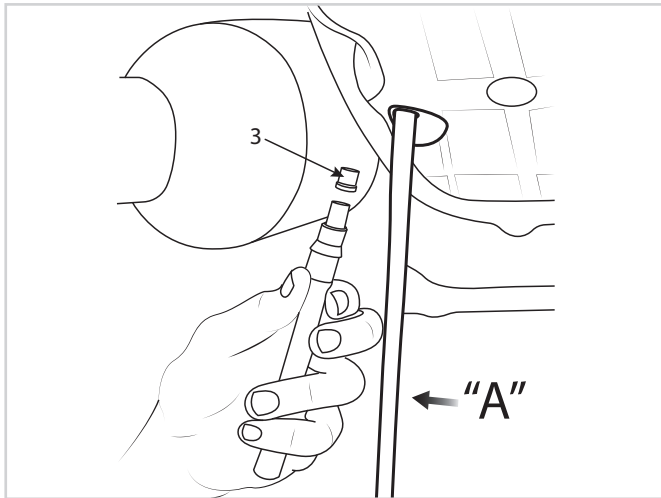

13. Remove the adapter "2". Excess oil now starts flowing out of the sump.

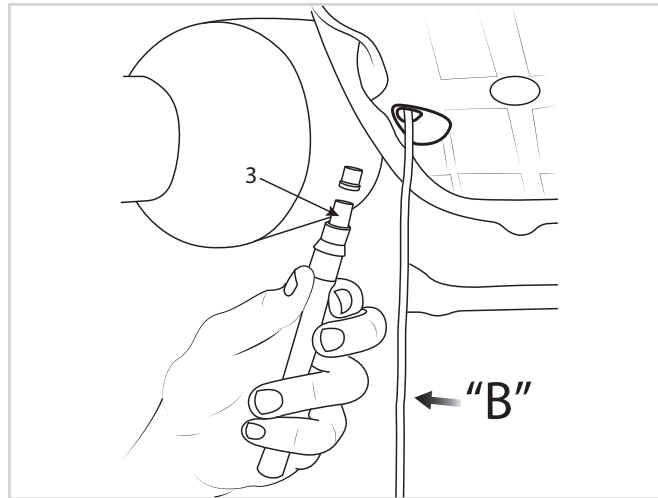

14. Wait until situation "B", before installing the sump plug "3" with a **new** sealing ring.

Tightening torque for the sump plug: 22 Nm.

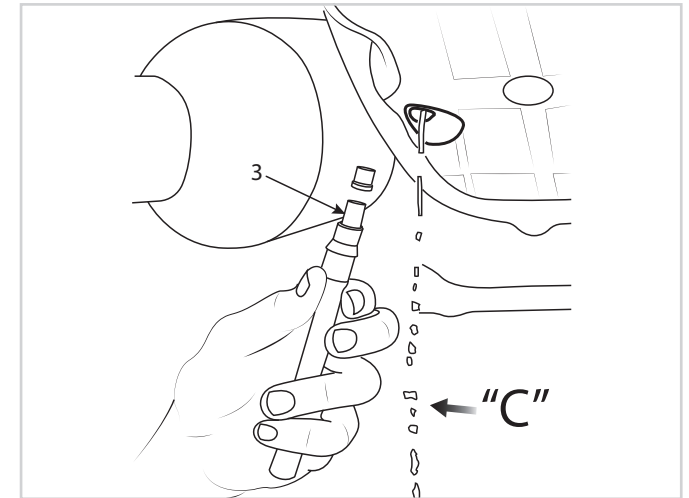

15. Switch the engine off.

16. Install the plating on the underside of the engine compartment.



ATTENTION:

Do not release more than 1 litre! See next instruction. Tightening torque for the sump plug: 22 Nm.



DSG 6 DQ250

The name DSG indicates the difference with the old "manual box": DSG stands for Direkt Schalt Getriebe or Direct Shift Gearbox. The system works many times faster than a conventional gearbox, partly because the next gear is already ready to be engaged. Where a manual transmission has only one clutch, a DSG 6 has two. The same goes for the primary shaft; there are also two of them. So you actually have access to two sub-gearboxes that work together in one housing: 1 sub-gearbox for the odd-numbered gears and 1 sub-gearbox for the even-numbered gears.



AUDI A3 8P 2003-2012

DSG 6 - DQ250

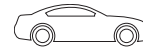

AUDI TT 8N 1998-2006

DSG 6 - DQ250



AUDI TT 8J 2006-2014

DSG 6 - DQ250

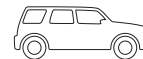

SEAT ALHAMBRA 710 2010-2019

DSG 6 - DQ250

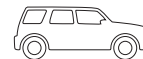

SEAT ALTEA 5P1, 5P5, 5P8 2004-2015

DSG 6 - DQ250



SEAT LEON 1P1 2005-2012

DSG 6 - DQ250

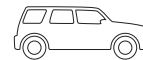

SEAT TOLEDO III 5P2 2004-2009

DSG 6 - DQ250



ŠKODA OCTAVIA 1Z 2004-2013

DSG 6 - DQ250



ŠKODA SUPERB 3T 2008-2015

DSG 6 - DQ250



ŠKODA YETI 5L 2009-2017

DSG 6 - DQ250



VW CADDY III 2K, 2C 2004-2015

DSG 6 - DQ250



VW CC 358 2011-2019

DSG 6 - DQ250

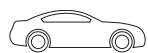

VW EOS 1F7, 1F8 2006-2015

DSG 6 - DQ250



VW GOLF IV 1J 1997-2004

DSG 6 - DQ250



VW GOLF V 1K 2003-2009

DSG 6 - DQ250



VW GOLF VI 5K1, 517, AJ5 2008-2012

DSG 6 - DQ250



VW JETTA III 1K2 2005-2011

DSG 6 - DQ250



VW JETTA IV 162, 16A 2011-2019

DSG 6 - DQ250



VW NEW BEETLE 5C1 2011-2019

DSG 6 - DQ250



VW PASSAT 3C2, 3C5 2005-2010

DSG 6 - DQ250



VW PASSAT 362, 365 2010-2014

DSG 6 - DQ250



VW SCIROCCO 137 2008-2014

DSG 6 - DQ250



VW SHARAN 7N 2010-2019

DSG 6 - DQ250



VW TIGUAN 5N 2007-2016

DSG 6 - DQ250



VW TOURAN 1T1, 1T2 2003-2010

DSG 6 - DQ250



VW TOURAN 1T3 2010-2015

DSG 6 - DQ250



VW GOLF PLUS 5M1, 1KP 2005-2014

DSG 6 - DQ250

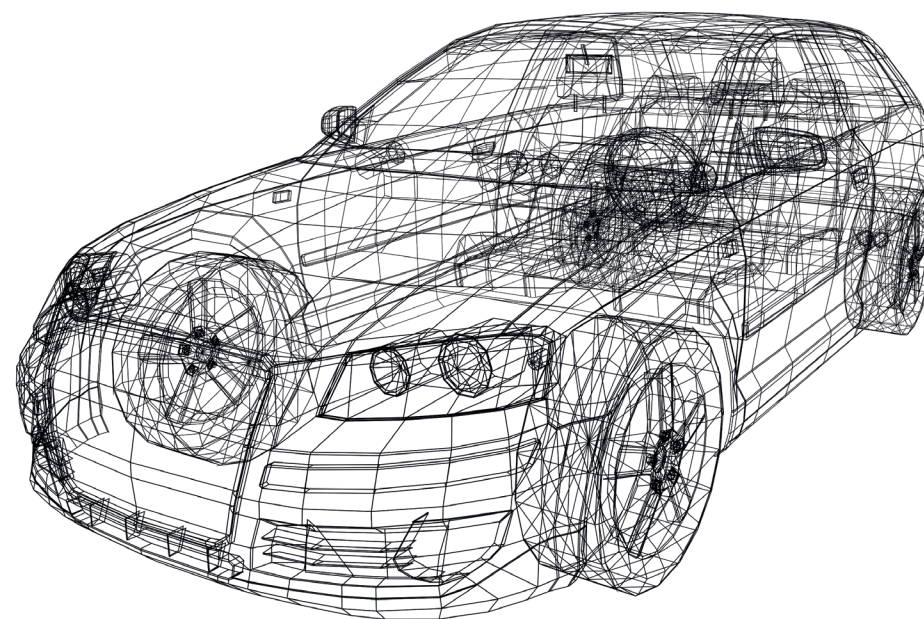

! KNOWN COMPLAINTS

- › The gearshift indicator ("PRNDS") on the dashboard will flash
- › The gearbox does not shift
- › The gearbox shifts randomly to "N" or an illogical gear

✓ CAN BE REMANUFACTURED

OBD II	VAG	Description
P0701	17085	Transmission control system, implausible signal
P0715	17099	Gearbox input speed sensor G182, error in electrical circuit
P0722	17106	Speed sensor G195, no signal
P0735	17119	5th gear, incorrect ratio
P0746	17130	Pressure control valve N215 fluid pressure, break / short circuit to ground
P0756	17140	Solenoid valve 2 (N89), break / short circuit to ground
P0761	17145	Solenoid valve 3 (N90), break / short circuit to ground
P0766	17150	Solenoid valve 4 (N91), break / short circuit to ground
P0771	17155	Solenoid valve 5 (N92), break / short circuit to ground
P0776	17160	Pressure control valve 2 (N216), break / short circuit to ground
P1604	18012	Control module defective
P1707	18115	Fault in mechatronic module
P1740	18148	Clutch temperature monitoring (G509)
P1746	18154	Supply voltage for solenoid valve, electrical fault in circuit
P1813	18221	Pressure control valve 1 (N215), electrical fault in circuit
P1814	18222	Pressure control valve 1 (N215), interruption / short circuit to ground
P1815	18223	Pressure control valve 1 (N215), short circuit to B +
P1818	18226	Pressure control valve 2 (N216), electrical fault in circuit
P1819	18227	Pressure control valve 2 (N216), break / short circuit to ground
P1820	18228	Pressure control valve 2 (N216), short circuit to B +
P1823	18231	Pressure control valve 3 (N217), electrical fault in circuit
P1824	18232	Pressure control valve 3 (N217), interruption / short circuit to ground
P1825	18233	Pressure control valve 3 (N217), short circuit to B +
P1828	18236	Pressure control valve 4 (N218), electrical fault in circuit
P1829	18237	Pressure control valve 4 (N218), interruption / short circuit to ground
P1830	18238	Pressure control valve 4 (N218), short circuit to B +
P1833	18241	Pressure control valve 5 (N233), electrical fault in circuit
P1834	18242	Pressure control valve 5 (N233), interruption / short circuit to ground
P1835	18243	Pressure control valve 5 (N233), short circuit to B +

P1838	18246	Pressure control valve 6 (N371), electrical fault in circuit
P1839	18247	Pressure control valve 6 (N371), break / short circuit to ground
P1840	18248	Pressure control valve 6 (N371), short circuit to B +
P2732	19164	Pressure control valve 6 (N371), break / short circuit to ground



REMANUFACTURE MAY BE POSSIBLE ADDITIONAL DIAGNOSIS REQUIRED

OBD II	VAG	Description
P0716	17100	Gearbox input speed sensor (G182), implausible signal

First check sensor G182 for contamination by metal particles.

If there is any contamination, check the gearbox thoroughly for mechanical wear/damage. Then also check the gearbox oil filter, as it can become clogged. In this case, the oil will circulate through the bypass, which means that the oil will no longer be filtered. This may cause contamination of sensors.

Then clean the sensor and check that the error code is still present. If this is the case, then it is still plausible that the TCU is defective and needs to be remanufactured.

OBD II	VAG	Description
P2711	19143	Implausible gear shift sequence

First check the accelerometer magnets for contamination by metal particles. If there is any contamination, check the gearbox thoroughly for mechanical wear/damage. Then also check the gearbox oil filter, as it can become clogged. In this case, the oil will circulate through the bypass, which means that the oil will no longer be filtered. This may cause contamination of sensors.

Then clean the magnets and check that the error code is still present. If this is the case, then it is still plausible that the TCU is defective and needs to be remanufactured.

If in doubt, please contact our Customer Service.

Telephone: 01206 849920

PIN ASSIGNMENT

Pin 1	K-line
Pin 3	Tiptronic tip -
Pin 6	Dashboard speed signal
Pin 7	-
Pin 10	CAN high
Pin 11	Power supply 12V +30
Pin 12	Reverse signal ("R")
Pin 13	Power supply 12V +15
Pin 14	Tiptronic tip +
Pin 15	CAN low
Pin 16	Ground 31
Pin 17	P/N signal (start control)
Pin 18	Power supply 12V +30
Pin 19	Ground 31

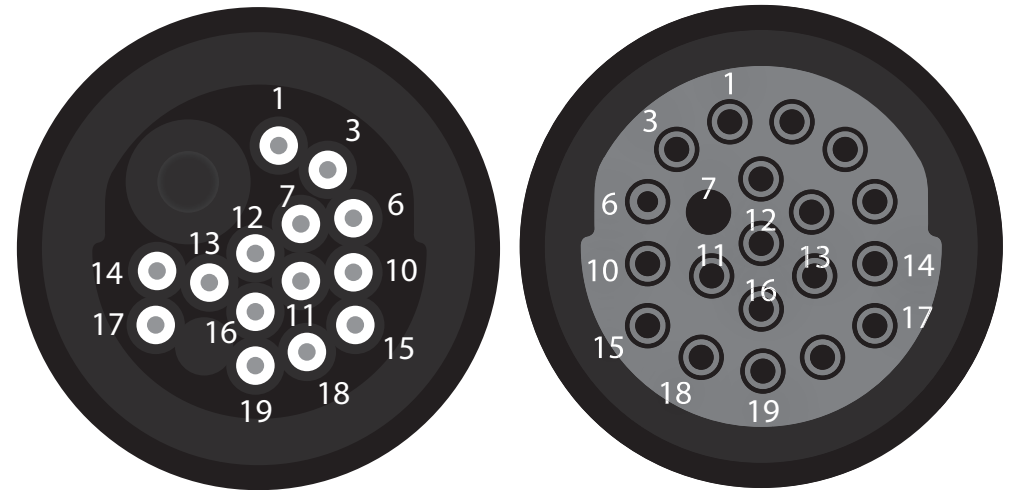

HYDRAULIC SCHEMATIC

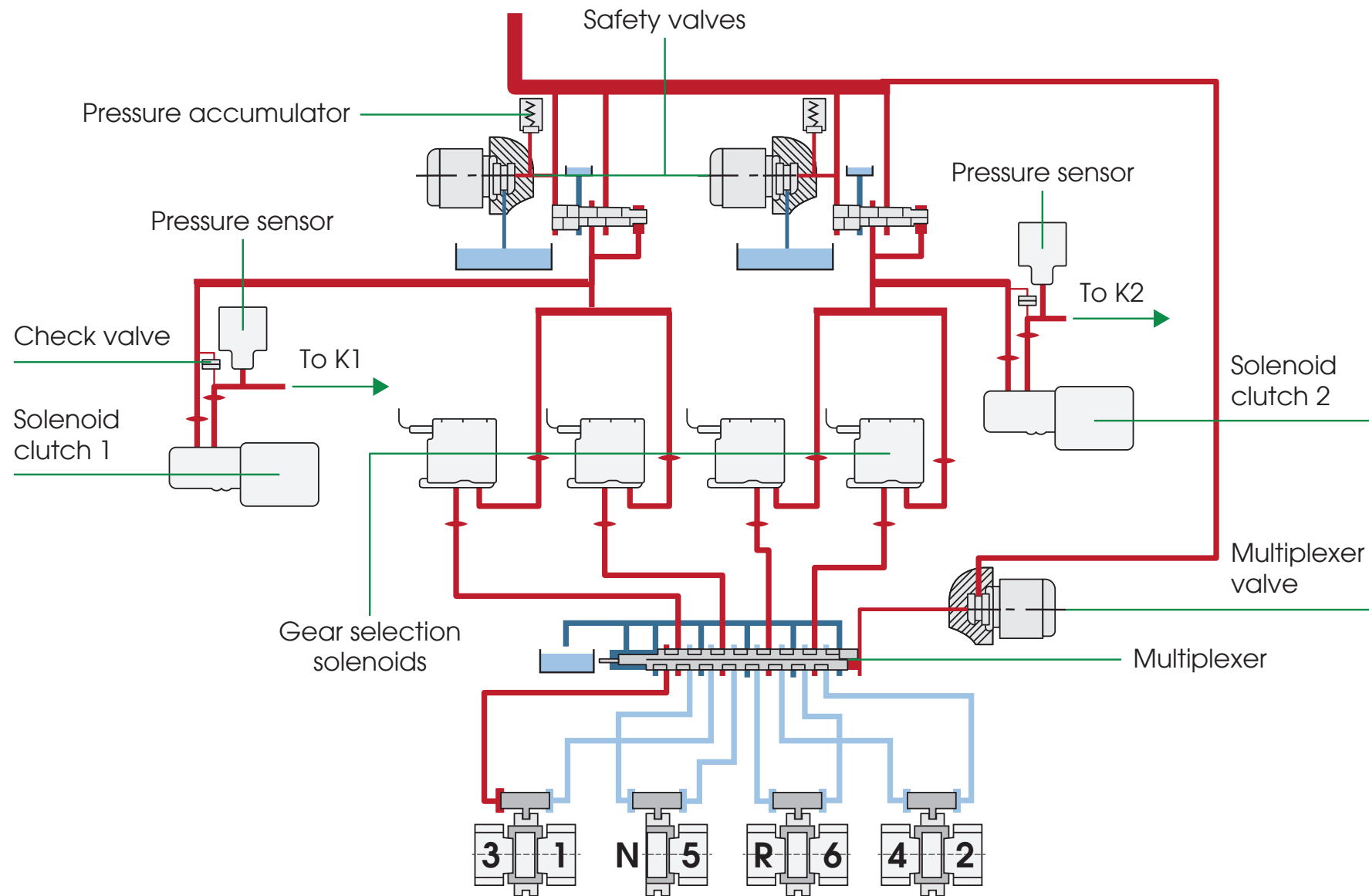

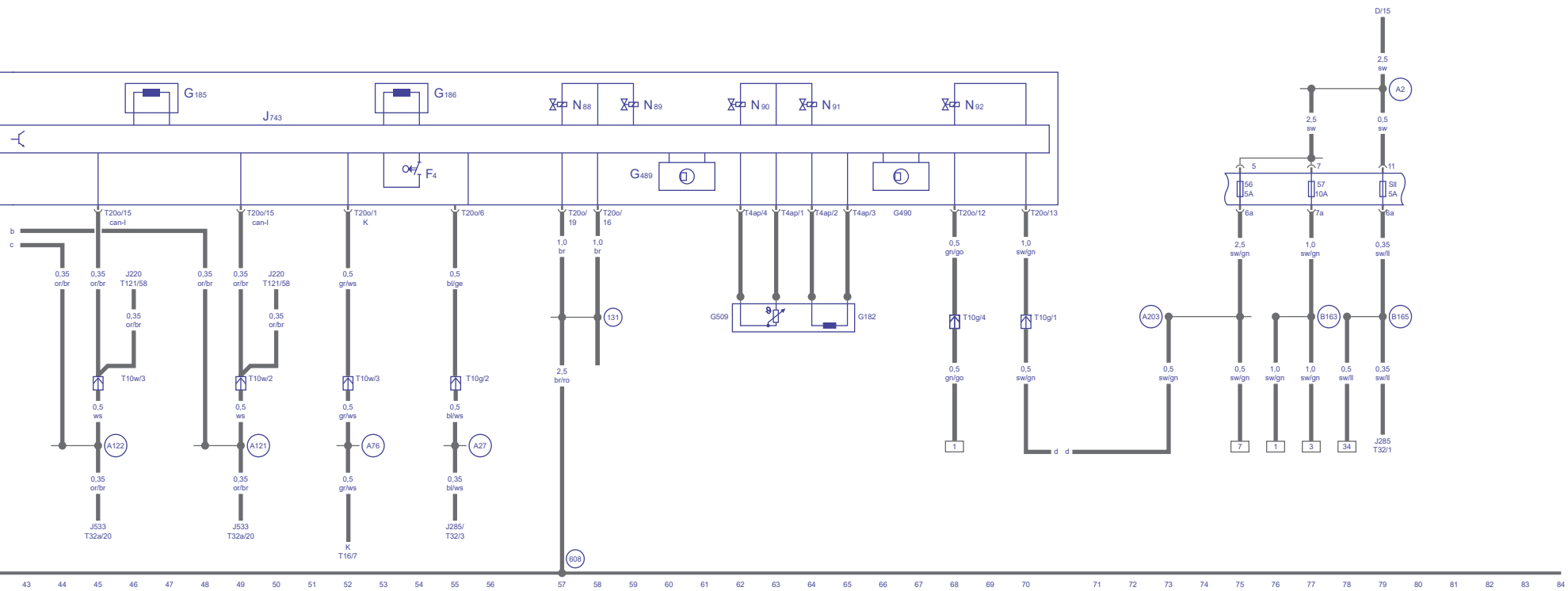

GENERAL OPERATION

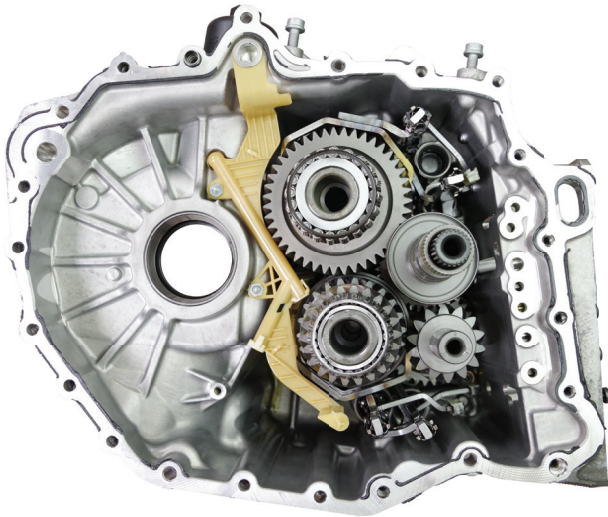

The DSG 6 gearbox is an automatic Volkswagen AG gearbox. DSG stands for 'Direktschaltgetriebe' or 'Direct Shift Gearbox' and the 6 stands for six forward gears. The designation 'DQ250' is also used for this gearbox. The Q ('Quermotor') indicates that this gearbox is used for transverse engines.

Mechanically, the DSG 6 gearbox can be described as a manual gearbox with two wet multi-plate clutches, two

drive shafts (input, primary) and two output shafts (secondary). An electronically controlled hydraulic control (Mechatronic) ensures that the gearbox can operate fully automatically. As an option, an additional manual shift option can be selected (Tiptronic).

A dual mass flywheel connects the crankshaft of the engine with the two clutch housings (outer plate carriers) which together (firmly together) rotate in line with the crankshaft. The two inner plate supports rotate independently of each other around the same shaft and each drives its own drive shaft via a fixed connection.

Drive shaft 1 rotates inside the hollow **drive shaft 2**.

On drive shaft 1 are the gears for 1st, 3rd, 5th and reverse gear; the gears for 2nd, 4th and 6th gear are on drive shaft 2. When shifting from one gear to the next, the next gear is therefore shifted from one drive shaft to the other, where the next gear has already been engaged on the corresponding output (main) shaft. When shifting gears, the clutch to the drive shaft of the 'old' gear is decoupled in one smooth movement and the clutch to the drive shaft of the 'new' gear is coupled in one smooth movement. So there is an overlap in the drive through both gears.

In addition, when shifting up, the engine torque is slightly lowered, while when shifting down, the engine torque is slightly increased. All in all, this ensures a fast and smooth switching action with no noticeable interruption in propulsion.

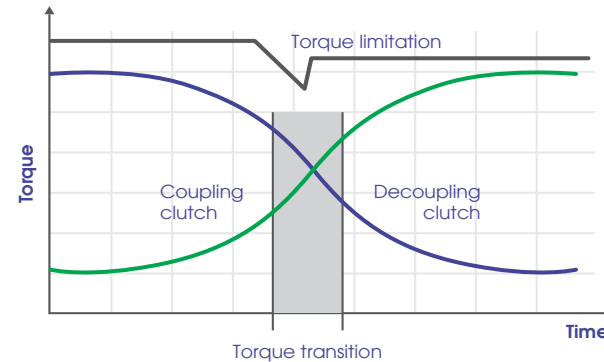

Exchanging information

Shifting, clutch activation and clutch de-activation are controlled from the central gearbox control unit, the Mechatronic (J743). This consists of an electronic control device and an electro-hydraulic control unit. The Mechatronic is built against the gearbox and forms part of the hydraulic circuit of the gearbox.

The Mechatronic not only receives the necessary information from its own sensors but also exchanges information with the various measuring and control devices in the car via the CAN bus, for example:

- › Gear selector lever (E313, J587)
- › ABS/ESP/EDS controller (J104)
- › Controller with display in the instrument panel (J285)
- › Electrical installation controller (J519)
- › Steering angle sensor (G85)
- › Controller for multi-function steering wheel (J453)
- › Controller for trailer recognition (J345)
- › Controller for engine (J220, J623)
- › Controller for diesel injection system (J248)
- › Controller for steering column (J527)
- › Diagnostic interface for data bus (J533)

Schematics of a DSG 6 gearbox

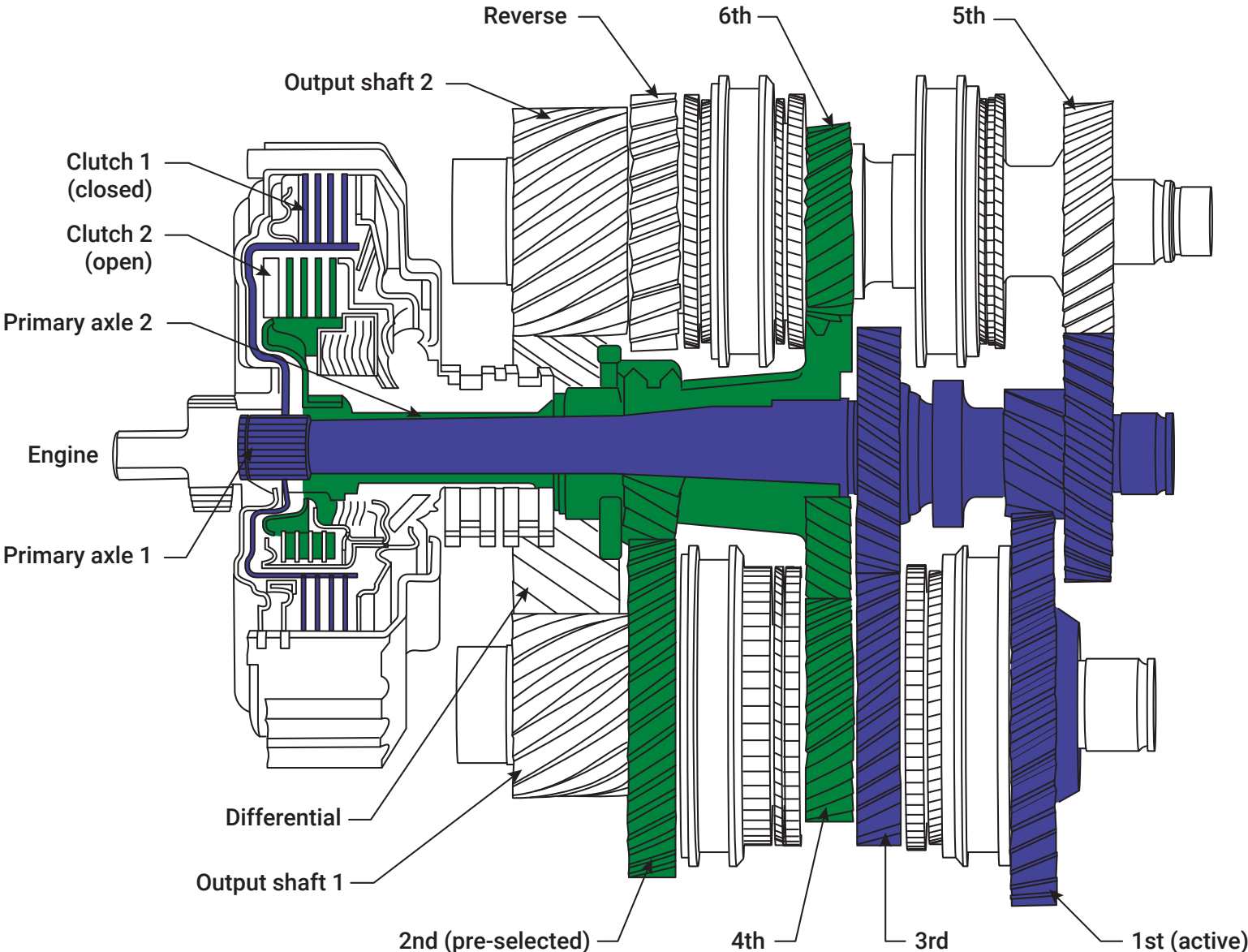

THE MECHATRONIC IN DETAIL

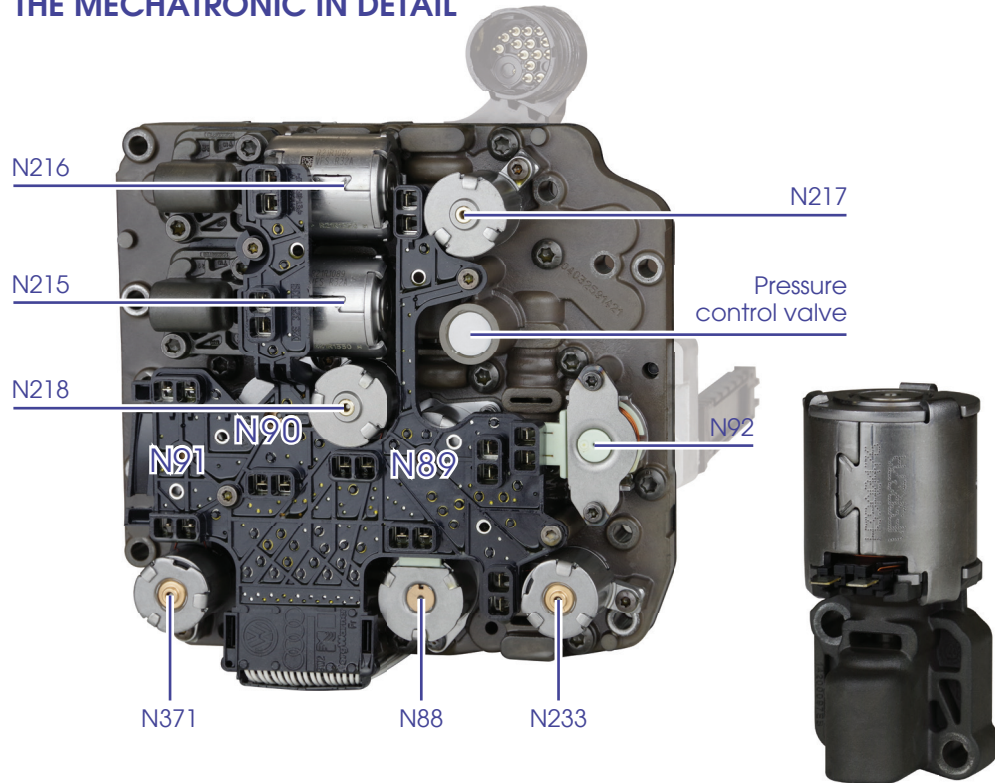

The Mechatronic has five shift (yes/no) valves and six control (modulation) valves. The five shift valves (N88, N89, N90, N91 and N92 (for the multiplexer, see hydraulic diagram) operate the shift forks that engage the gear wheels on the output shafts.

The six control valves regulate the various pressures required: the head pressure in the hydraulic system (N217), the pressure for the cooling oil in the multi-plate clutches (N218), the pressure at which the two multi-plate clutches are energised (pressed) (N215 and N216), and the pressure in the two safety valves which, in the event of a malfunction, are actuated in order to depressurise the respective gearbox part (N233 and N371).

Pressure control valves N215, N216, N233 and N371 have an **increasing** flow/pressure curve; the control pressure increases as the control flow increases. This means that if the control valve is de-energised, the control pressure will be zero.

In case of a fault

If valves N215 and N233 experience a fault, gearbox section 1 (with drive shaft 1) is switched off and the limp mode is started. The car can only be driven in second gear and a malfunction is reported in the instrument panel.

If valves N216 and N371 experience a fault, gearbox section 2 (with drive shaft 2) is switched off and the limp mode is started. The car can then only be driven in first and third gears and a fault message is displayed in the instrument panel.

Pressure control valves N217 and N218 have a **decreasing** flow/pressure curve; the control pressure decreases as the control flow increases. This means that if the control valve is de-energised, the control pressure is at its maximum.

In case of a fault

If valve N217 experiences a fault, the maximum primary pressure is set. Shifting gears may become noisy, fuel consumption will increase and an error message will be displayed in the instrument panel.

If valve N218 experiences a fault, the maximum cooling oil flow is set. Fuel consumption will increase, gear shifting problems may occur at low outside temperatures and a malfunction is reported in the instrument panel.

Actuator	Function
N88	Shift valve for shifting 1st and 5th gears
N89	Shift valve for shifting 3rd gear and neutral
N90	Shift valve for shifting 2nd and 6th gears
N91	Shift valve for shifting 4th and reverse gear
N92	Switching valve for the multiplexer
N215	Pressure control valve for clutch K1
N216	Pressure control valve for clutch K2
N217	Main pressure control valve
N218	Pressure relief valve for the clutch cooling oil
N233	Safety valve for sub-gearbox 1
N371	Safety valve for sub-gearbox 2

THE TCU IN DETAIL

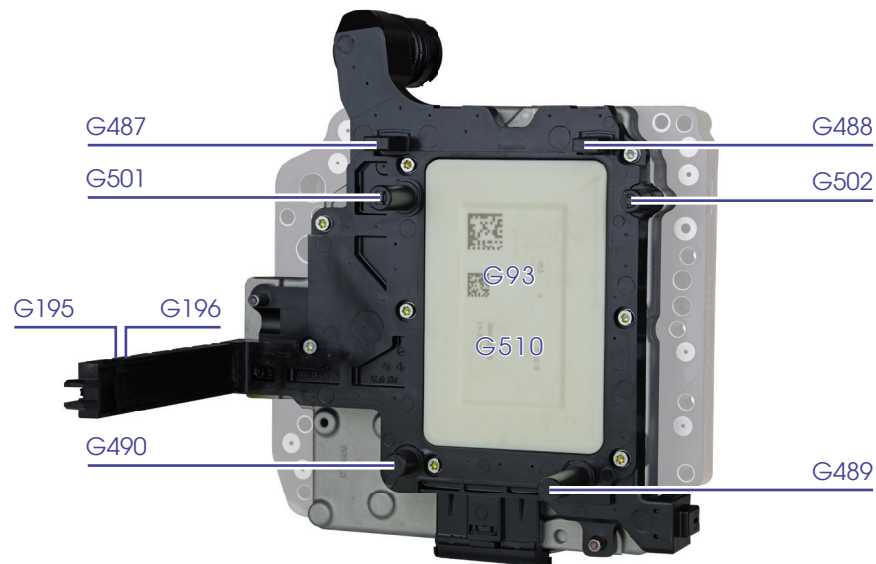

Sensor	Function
G93	Gearbox oil temperature sensor
G182	Speed sensor input shaft gearbox
G193	Pressure sensor for hydraulic pressure of clutch K1
G194	Pressure sensor for the hydraulic pressure of clutch K2
G195	Speed sensor for the second gearbox output shaft
G196	Speed sensor for the second gearbox output shaft
G487	Position detection sensor for the selector fork for 1st and 3rd gears
G488	Position detection sensor for the selector fork for 2nd and 4th gears
G489	Position detection sensor for the selector fork for 6th and reverse gears
G490	Position detection sensor for the selector fork for 5th gear and neutral
G501	Speed sensor for drive shaft 1
G502	Speed sensor for drive shaft 2
G509	Gearbox oil temperature sensor at the multi-plate clutch
G510	Gearbox oil temperature sensor in the electronic control unit

In order to provide the Mechatronic with the necessary information, the TCU receives information from a number of sensors:

The pressure sensors for the hydraulic pressure on the multi-plate clutches

G193 and G194

The oil temperature sensors

G93, G509 and G510

The speed sensors

G501 and G502 for the two drive shafts

G195 and G196 for the second output shaft

G182 for the input shaft

The position detection sensors for the selector forks

G487, G488, G489 and G490

Most of the sensors are built into the TCU; only G182 and G509 are placed (next to each other) outside the Mechatronic.

Problems caused by contaminated gearbox oil

In order to be able to control the gearbox properly, it is important that the sensors, the shift valves and the control valves in the Mechatronic work properly. Because the oil in and with which these components work is also used to cool and/or lubricate the multi-plate clutches, gearbox gears, bearings and the synchronisation, it can become very contaminated.

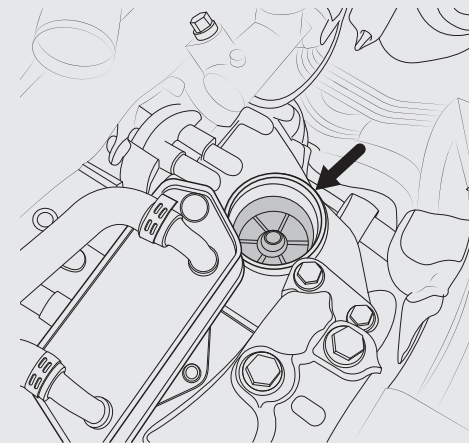

If the contamination of the oil becomes so great that the gearbox oil filter becomes clogged, the oil will circulate through the bypass, which means that the oil will no longer be filtered. Wear and tear can then accumulate on the sensors and in the shift and control valves, causing the Mechatronic to malfunction and adversely affecting the operation of the gearbox. It is therefore important that the oil and filter of the DSG 6 gearbox are changed every 60,000 km.

REMOVING THE MECHATRONIC

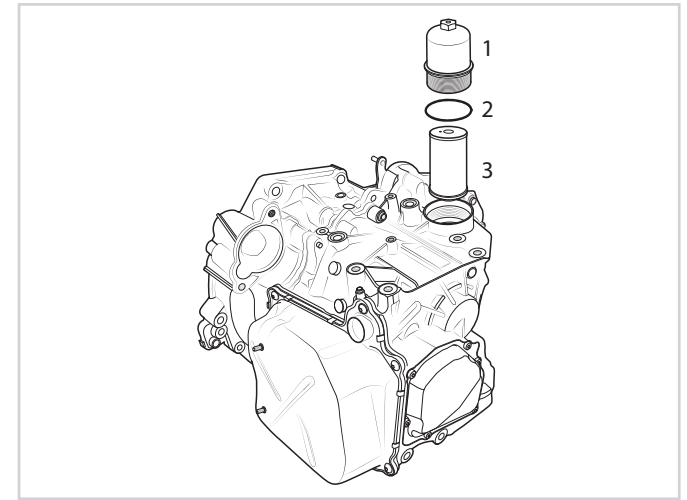
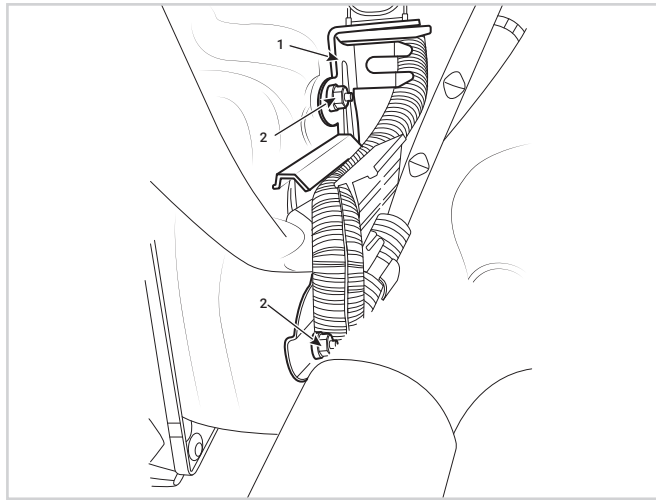
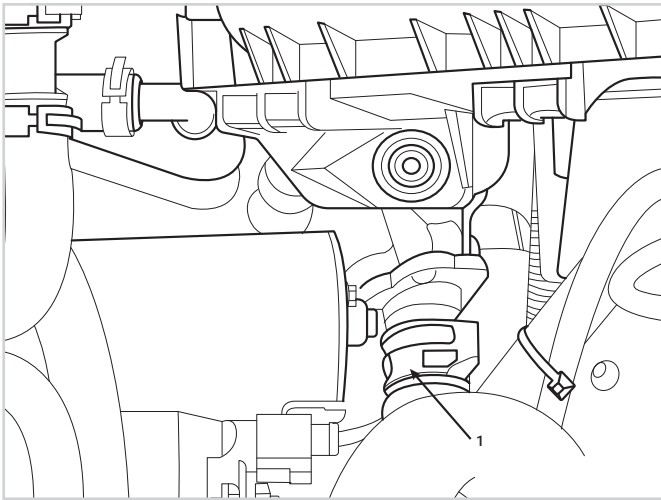

ATTENTION:

Considering the high number of cars in which the DSG 6 Mechatronic is mounted, this chapter only focuses on the steps that are universally applicable. Always refer to the manufacturer's official documentation for specific instructions.

Prior to disassembly

1. Set the selector lever to "P".
2. If there is a radio with a radio code, make sure that the radio code is known before disconnecting the battery.
3. Turn off the ignition and disconnect the battery ground lead.

Disconnecting the plug with the wiring harness

1. Turn the bayonet connection of the Mechatronic plug anticlockwise and remove the plug. Both O-rings have to be **renewed**. Remove (if present) the sound-proofing panel under the gearbox.
2. Remove (if present) the connecting hose between the intercooler and the intercooler tube.
3. Loosen the two M6 nuts (2) of the wiring guide bracket (1) and remove the bracket.
4. Guide the wiring upwards and temporarily tie it there.
5. Place a container that can collect at least 5 litres of oil under the gearbox.

Changing the gearbox oil filter

1. Remove all parts that prevent the oil filter from being undone. Think for example of the engine cover and the air filter housing.
2. Rotate the gearbox oil filter housing (1).
3. Keep the oil filter housing slightly tilted before removing it. This will allow the oil remaining in the oil filter to drain out of the filter into the gearbox.
4. Now remove the oil filter (3).
5. O-ring (2) must be replaced. Lubricate the **new** O-ring with DSG oil.
6. Also lubricate the small O-ring at the bottom of the filter with DSG oil

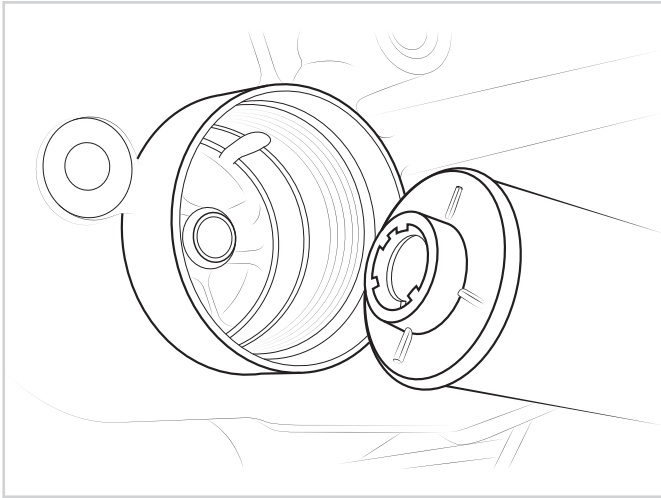

7. Fit the **new** oil filter and the **new** large O-ring and tighten the oil filter housing to a torque of 20 Nm.
8. Reassemble all previously removed parts.

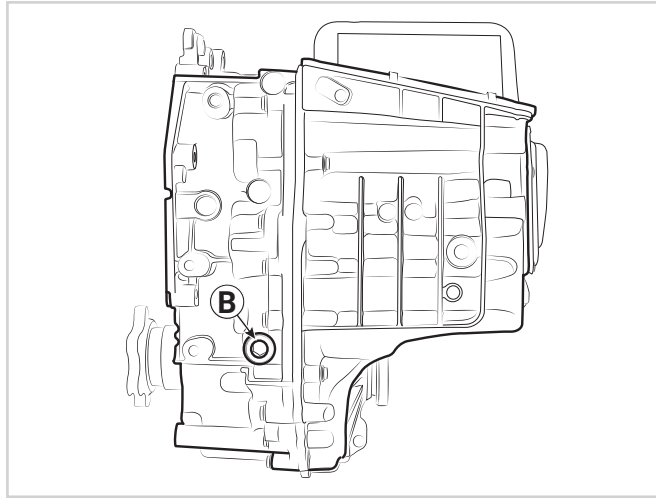

Draining the oil and removing the sump

1. Unscrew oil drain plug B at the pendulum support and then disassemble the overflow pipe fitted in the hole with an 8 mm Allen key. About 5 litres of oil will now be released from the gearbox.
2. When the gearbox is empty, install the overflow pipe again with a tightening torque of 3 Nm.

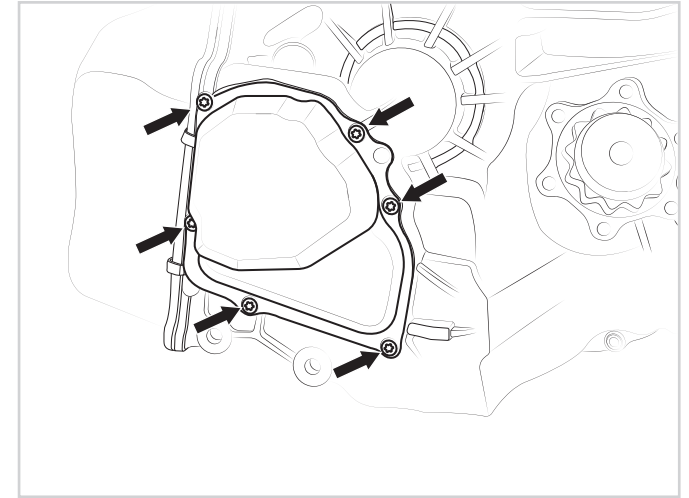

3. Loosen the bolts of the oil pump cover (on the side of the gearbox) crosswise and remove the cover.



ATTENTION:

Make sure that no dirt gets into the oil pump.

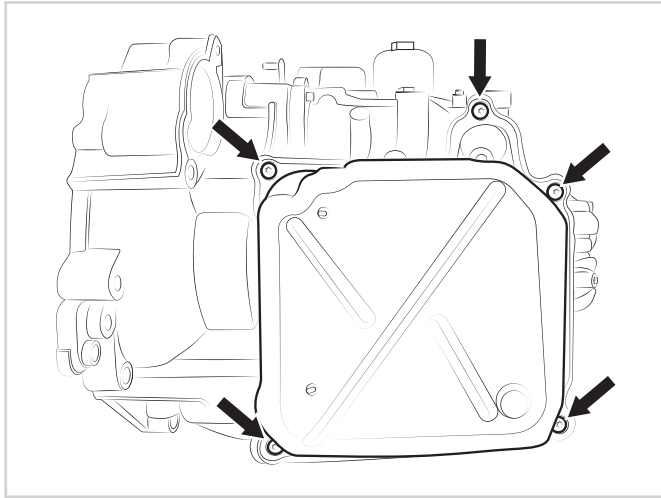

4. Loosen the oil sump screws crosswise. These bolts must be **renewed**.
5. Remove the oil sump with the gasket. The gasket must be **renewed**.
6. Make sure that no dirt gets into the Mechatronic.

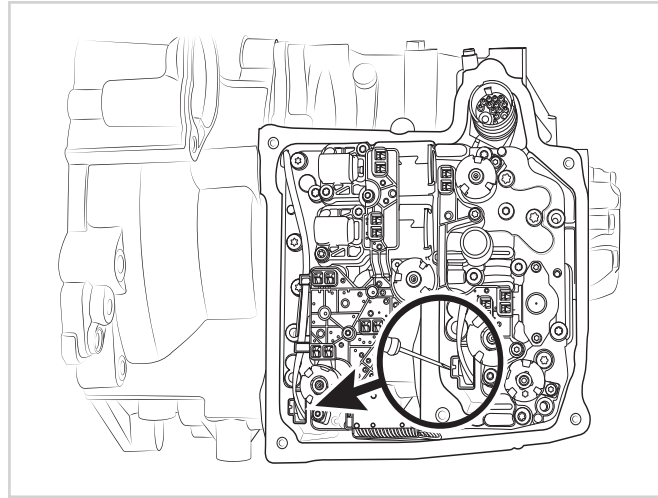

Removing the Mechatronic

1. Carefully unplug input speed sensor G182 and oil temperature sensor G509. Use two flathead screwdrivers: one to unlock and one to separate the connector from the socket. Do not pull on the wiring! When the plug is disconnected, disconnect the wiring from the terminals (see arrows).

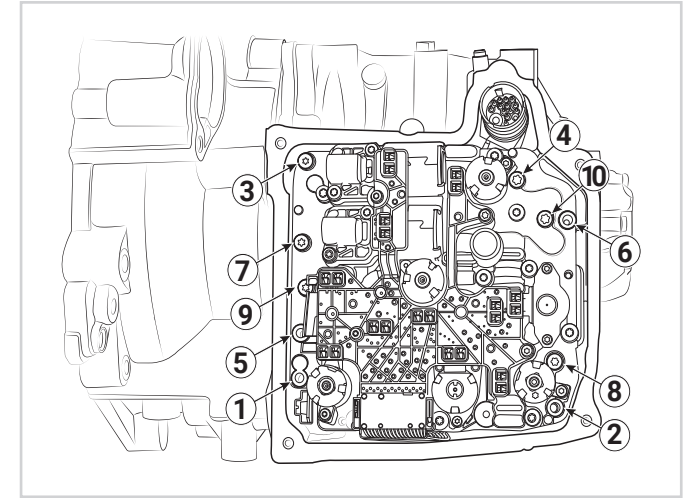

2. Remove the screws from the Mechatronic in the order indicated.



ATTENTION:

Before touching the Mechatronic, you must first touch a grounded object (e.g. the lift) in order to discharge any static electricity.

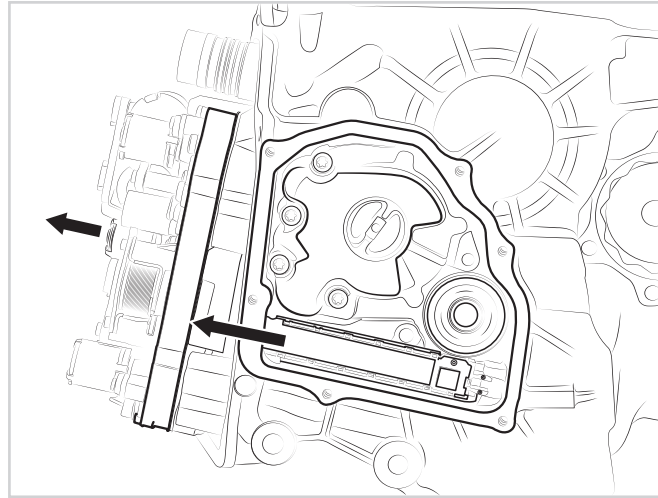
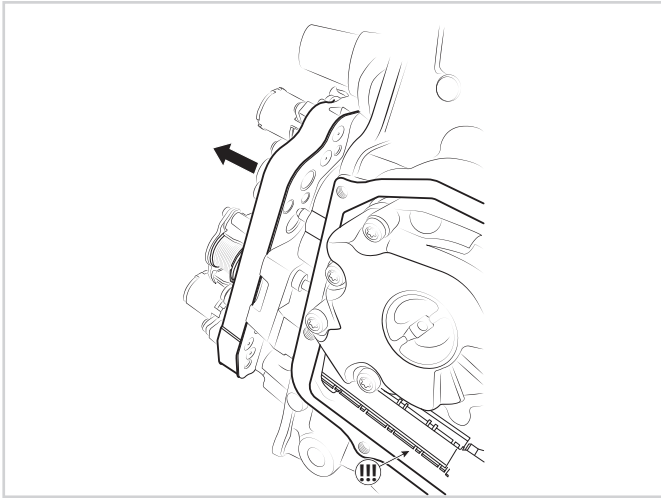

3. Carefully remove the Mechatronic from the gearbox housing and pay attention to the long sensor arm (see !!!) under the oil pump. This is very vulnerable.
4. When the sensor arm of the Mechatronic has been completely pushed out of the gearbox housing, the Mechatronic can be removed with a rotating movement downwards. Make sure that the long sensor arm is not loaded.
5. Carefully lay the Mechatronic down with the long sensor arm up. Never lift the Mechatronic by the sensor arm because it breaks easily.

OFFER FOR REMANUFACTURE

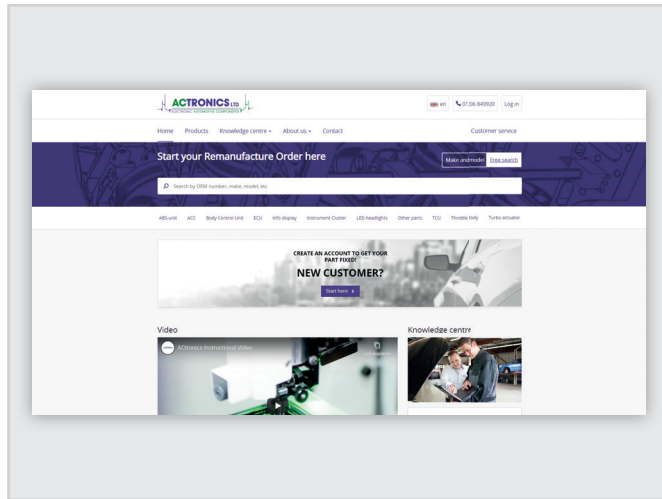

Sign up online

- › Go to www.actronics.co.uk and click on “Free search”.
- › Then enter “DSG 6” and the product will immediately appear on the screen.
- › Click on “View product” and follow the dropdown menu.
- › You have now selected the right product.
- › Now click on “Next” and log in to complete the registration.
- › Print the [Remanufacture Order Form](#) after registration.



Shipping

To prevent transport damage, the Mechatronic of the DSG 6 must be sent in specially designed transport packaging. Before sending the Mechatronic, please contact our Customer Service: 01206 849920. They will then send you the transport packaging free of charge.

**IMPORTANT:**

Enclose the printed Remanufacture Order Form with the product in the transport packaging. This is crucial for identification upon receipt.

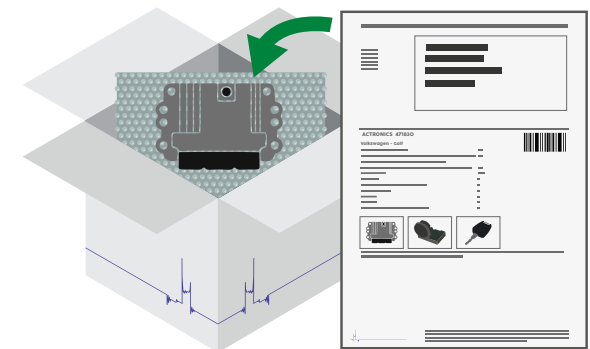

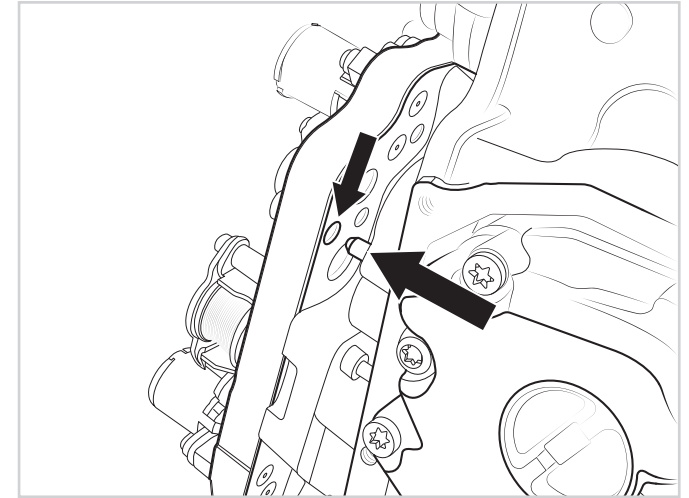
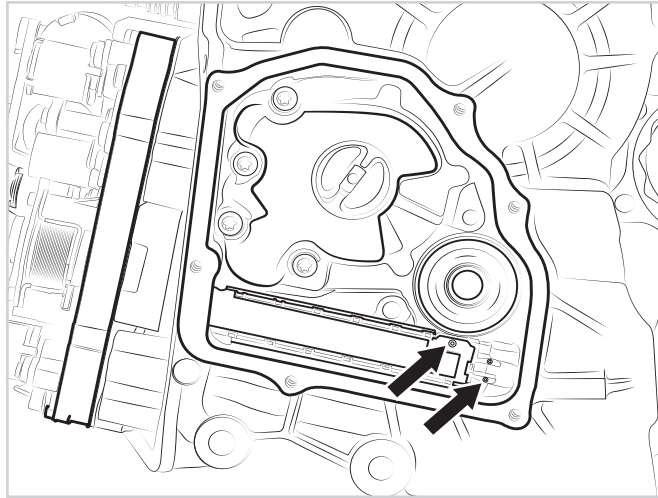
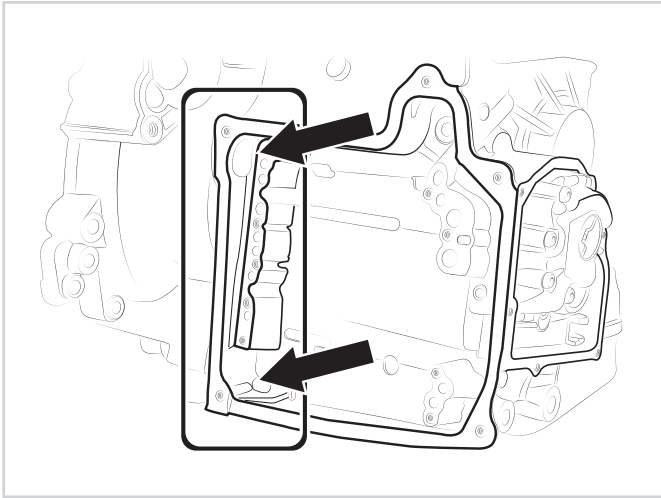
INSTALLING THE MECHATRONIC AFTER REMANUFACTURING**Installing the Mechatronic**

1. First check whether the speed sensor G182 and the oil temperature sensor G509 are installed.
2. Carefully insert the Mechatronic into the gearbox housing. Pay close attention to the long sensor arm: it must be correctly positioned in the seat of the gearbox housing
3. Check that the alignment pin is properly positioned in the recess.

**ATTENTION:**

Be careful not to pinch and/or damage the wiring for the G182 and G509 sensors.

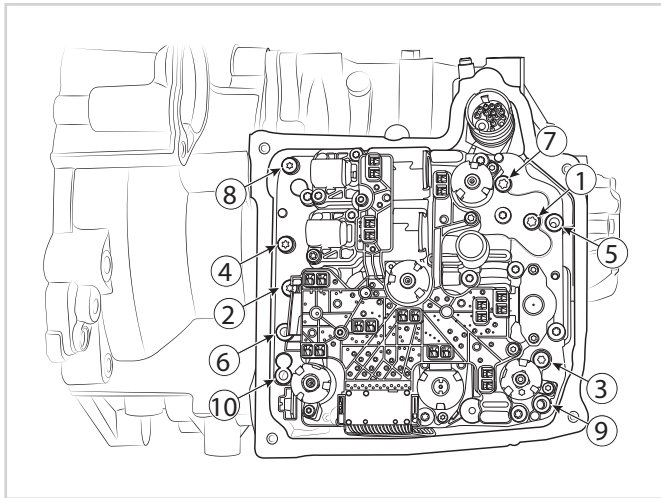

4. Mount the bolts of the Mechatronic hand-tight.
5. Now tighten the bolts in the specified order
Tightening torque: 5 Nm + 90°
6. Secure the wiring for the G182 and G509 sensors with clamps: first the upper clamp, then the lower clamp.
7. Mount the plug of sensors G182 and G509.

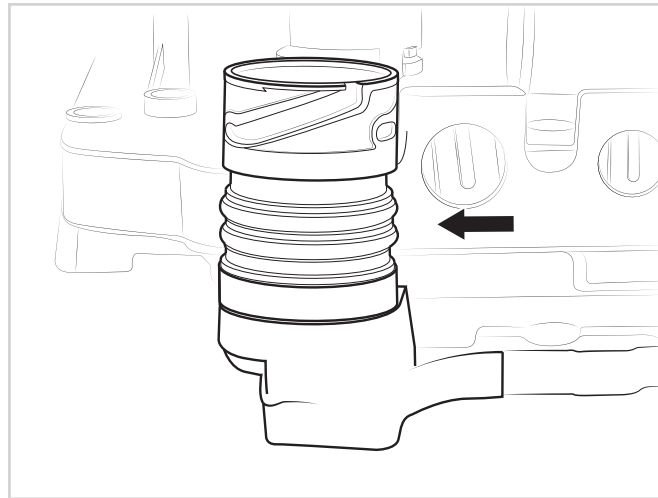

8. Replace both O-rings on the Mechatronic connector: clear the sealing surfaces of the connector of old oil and dirt and lubricate the **new** O-rings with DSG oil.

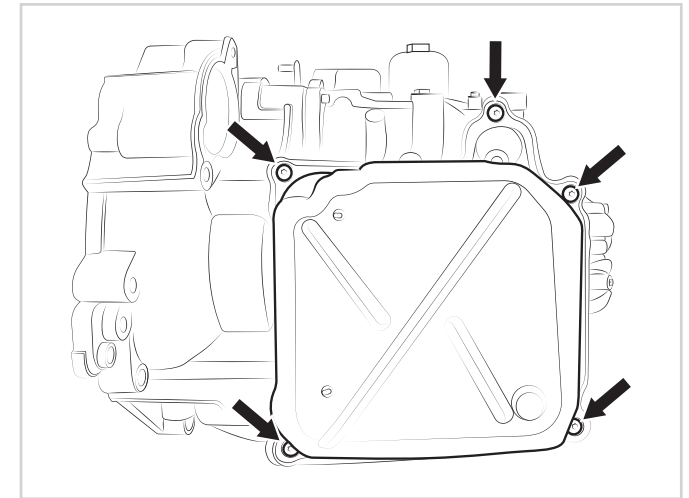

9. Insert the oil sump with **new** gasket. Make sure no wiring is pinched.
10. Install the **new** bolts and tighten them crosswise.
Tightening torque: 10 Nm.

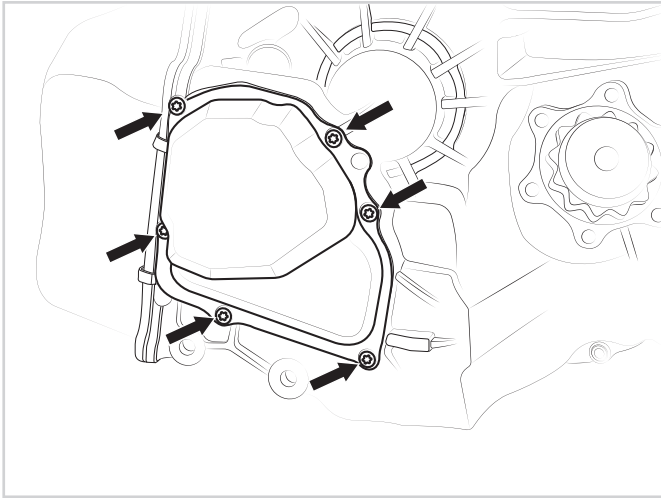

11. Fit the oil pump cover and fit the bolts.
12. Tighten the bolts crosswise in several steps. Tightening torque: 8 Nm.
13. Mount the wire guide bracket and tighten the two M6 nuts to 10 Nm.
14. Place the round connector on the Mechatronic plug and tighten the bayonet fitting clockwise.
15. If applicable, install the connecting hose between the intercooler and the intercooler tube.
16. Connect the battery ground cable, but do not start the engine yet!

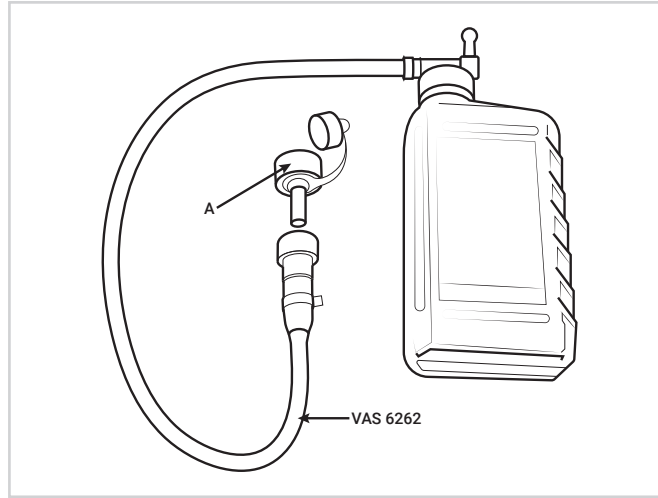

Filling with gearbox oil

1. Check that the overflow pipe is present in the hole of the drain plug.
2. Mount adapter "A" of VAS 6262 hand-tight in the drain opening.
3. Fill the gearbox with at least 5.5 litres of DSG oil via adapter "A" of VAS 6262: shake the DSG oil bottles before opening them.
4. Read the gearbox oil temperature using the factory scan tool (VAG-COM or VAS 5051).
5. Start the engine, hold down the brake pedal and select each selector lever position for about 3 seconds.
6. Return the selector lever to "P" and let the engine run.

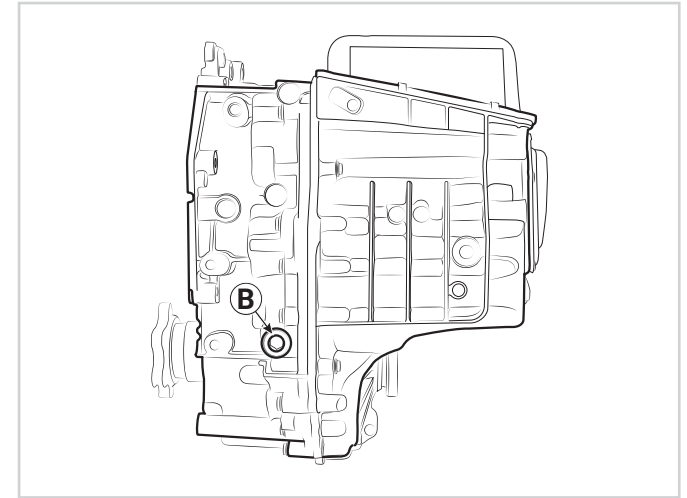

7. Disassemble (with engine running and gearbox temperature 35°C to 45°C) adapter "A" from VAS 6262.
 8. Excess oil will now flow over the overflow pipe. If this is not the case, oil must be added. Wait until the overflow turns to a drip. The gearbox is now full.
9. Install the drain plug with a **new** sealing ring. Tightening torque: 45 Nm.
10. Now turn off the engine.
11. If applicable, install the soundproofing panel under the gearbox.

TEACHING THE BASIC MECHATRONIC SETTINGS

The DSG 6 gearbox (DQ250, 02E) is a self-learning transmission. After the Mechatronic has been remanufactured and installed, only the basic settings need to be reset.

The easiest way to set the basic settings is to use the factory scan tool (VAG-COM or VAS 5051) with VCDS Version 10.64 or equivalent.

The following description is based on the use of VAG-COM:

1. Preconditions

- › DSG oil temperature between 30 °C and 100 °C (read this via (02) - (Auto Trans) - (Measuring block 019))
- › Selector lever in P
- › Ignition on
- › Engine on (idle) for at least one minute
- › Keep the brake pedal depressed for the entire procedure
- › Do not operate the accelerator pedal

2. Synchronisation

- › Go to (02) - (Auto Trans) - (Basic Settings 060) and select (Go!).
- › Wait until the measured values stabilise and the gearbox no longer makes any noise.
- › The screen then displays 'Basic Settings: ON'.

3. Calibration

- › Go to (02) - (Auto Trans) - (Basic Settings 061) and select (Go!).
- › Wait until the measured values stabilise and the gearbox no longer makes any noise. The screen then displays 'Basic Settings: ON'.

4. Clutch setting

For Mechatronic software version:

- › Go to (Basic Settings 062) and select (Go!).
- › Activate the 'Basic Settings' (ON/OFF/Next).

For Mechatronic software version \geq 0800:

- › Go to (Basic Settings 067) and select (Go!).
- › Activate the 'Basic Settings' (ON/OFF/Next).

5. Resetting the values of the clutch safety function

- › Go to (Basic Settings 068) and select (Go!).
- › Activate the 'Basic Settings' (ON/OFF/Next).

6. Resetting clutch pressure values

- › Go to (Basic Settings 065) and select (Go!).
- › Activate the 'Basic Settings' (ON/OFF/Next).

7. Resetting the values of the steering wheel paddles

- › Go to (Basic Settings 063) and select (Go!).
- › Activate the 'Basic Settings' (ON/OFF/Next).

8. Resetting ESP / Cruise Control values

- › Go to (Basic Settings 069) and select (Go!).
- › Activate the 'Basic Settings' (ON/OFF/Next).

9. Closing comments

- › Press (Done, Go Back).
- › Turn off the ignition.
- › Wait 15 seconds and turn on the ignition again.
- › Read out any error codes and delete them via (Fault Codes - 02).
- › To finalise, select: (Close Controller, Go Back - 06).

NOTE:

It is normal for the gearbox to make a noise while performing the learning procedure. Do not close the 'Basic Settings' sequence prematurely, even if you hear chattering sounds.

If necessary, perform the defined test drive:

1. The DSG oil temperature must remain between 30 °C and 100 °C.
2. Do not use Cruise Control.
3. In Tiptronic mode, drive from stationary through all gears up to and including 6th gear.
4. When driving, make sure you drive in 3rd and 5th gear for about 5 minutes and then in 4th and 6th gear for about 5 minutes.
5. Keep the engine speed for all gears at between 1200 and 3500 revolutions per minute.
6. Perform a powerful braking action in "D" (Drive) followed by full throttle acceleration.
7. Evaluate the creep and driving behaviour of the gearbox.
8. After the test drive, check the gearbox for leaks.

NOTE:

If the test drive cannot be performed in the recommended manner or in the time required, the remaining adjustments will be made automatically during normal driving. This may take a few more days.



DSG 7 DQ200

After the success of the DSG 6, a successor was inevitable. Having said that, a DSG 7 gearbox can't really be called a successor. This newer DSG version uses a dry clutch and can handle a bit less torque than its older brother. So why did Volkswagen AG make this choice? The answer can be found in weight and resistance. With regard to the environment and fuel consumption, the DSG 7 is the better option, as long as it doesn't require too much torque, that is...



AUDI A1 8X 2010-2018

DSG 7 - DQ200



AUDI A3 8P 2003-2012

DSG 7 - DQ200



AUDI TT 8J 2006-2014

DSG 7 - DQ200

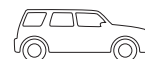

SEAT ALTEA 5P1, 5P5, 5P8 2004-2015

DSG 7 - DQ200



SEAT IBIZA V 6J5, 6J1, 6J8 2008-2017

DSG 7 - DQ200



SEAT LEON 1P1 2005-2012

DSG 7 - DQ200



SEAT TOLEDO III 5P2 2004-2009

DSG 7 - DQ200



ŠKODA FABIA 5J 2007-2014

DSG 7 - DQ200



ŠKODA OCTAVIA 1Z 2004-2013

DSG 7 - DQ200

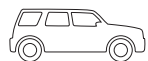

ŠKODA ROOMSTER 5J 2006-2015

DSG 7 - DQ200



ŠKODA SUPERB 3T 2008-2015

DSG 7 - DQ200

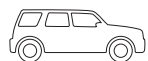

ŠKODA YETI 5L 2009-2017

DSG 7 - DQ200

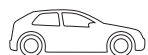

VW NEW BEETLE 5C1 2011-2019

DSG 7 - DQ200

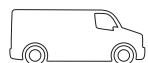

VW CADDY III 2K, 2C 2004-2015

DSG 7 - DQ200



VW GOLF V 1K 2003-2009

DSG 7 - DQ200



VW GOLF VI 5K1, 517, AJ5 2008-2012

DSG 7 - DQ200



VW JETTA III 1K2 2005-2011

DSG 7 - DQ200



VW JETTA IV 162, 16A 2011-2019

DSG 7 - DQ200

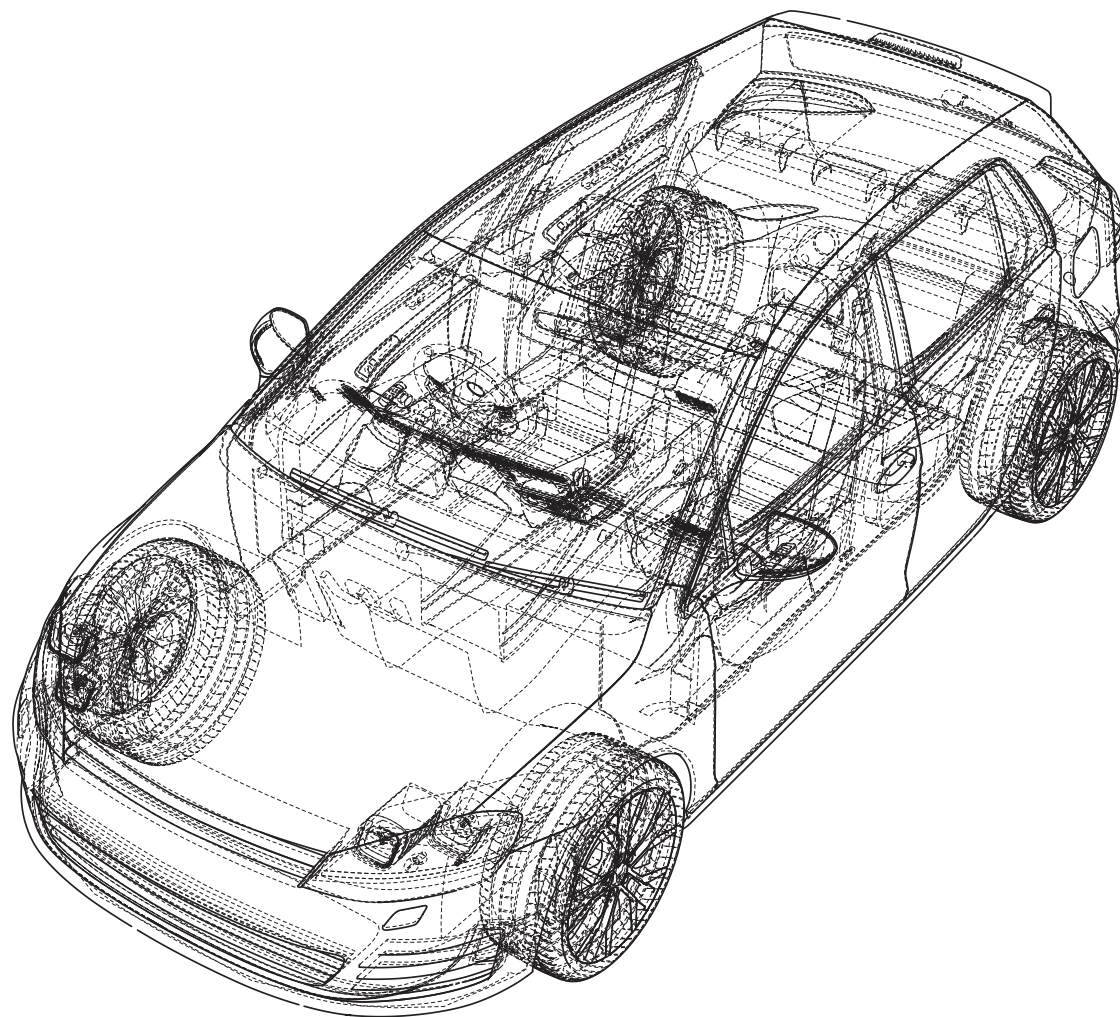

KNOWN COMPLAINTS

- › The gearshift indicator ("PRNDS") on the dashboard will flash
- › The gearbox does not shift
- › Short circuit: 30A fuse blown
- › Leakage and/or pressure loss

CAN BE REMANUFACTURED

OBDII	VAG	Description
P0562	16946	System voltage, voltage too low
P0841	17225	Sensor / pressure switch transmission fluid pressure A, implausible signal
P1604	18012	Control module defective
P177F	-	Hydraulic pump system, supply voltage too low
P17BF	-	Hydraulic pump system, overload protection
P1895	18303	Functional limitation due to pressure drop
P189C	-	Functional limitation due to insufficient pressure
U0101	28773	No communication with TCM

REMANUFACTURE MAY BE POSSIBLE ADDITIONAL DIAGNOSIS REQUIRED

OBDII	VAG	Description
P173A	-	Position sensor 1 for gear selector, implausible signal
P173B	-	Position sensor 2 for gear selector, implausible signal
P173C	-	Position sensor 3 for gear selector, implausible signal
P173D	-	Position sensor 4 for gear selector, implausible signal

Check the position sensors and the corresponding magnets for contamination by metal particles.

If there is any contamination, check the gearbox thoroughly for mechanical wear/damage. Then clean the sensor and check that the error code is still present. If this is the case, then it is still plausible that the TCU is defective and needs to be remanufactured.

If in doubt, please contact our Customer Service.

Telephone: 01206 849920

CANNOT BE REMANUFACTURED

OBDII	VAG	Description
P072A	-	Neutral not selectable
P072B	-	Reverse gear not selectable
P072C	-	1st gear not selectable
P072D	-	2nd gear not selectable
P072E	-	3rd gear not selectable
P072F	-	4th gear not selectable
P073A	-	5th gear not selectable
P073B	-	6th gear not selectable
P073C	-	7th gear not selectable

The above error codes usually appear after installing the Mechatronic. These error codes indicate that one or more shifting pins are not properly mounted in the forks of the gearbox.

In "Installing the Mechatronic" on page 84, we give tips on how to avoid this situation.

PIN ASSIGNMENT

Pin 8	Ground 31
Pin 9	Power supply 12V 30+ (30A)
Pin 10	Power supply 12V 15+ (10A)
Pin 11	K-line
Pin 12	CAN low
Pin 13	CAN high
Pin 16	P/N signal (start control)
Pin 24	Ground 31
Pin 25	Power supply 12V 30+ (15A)

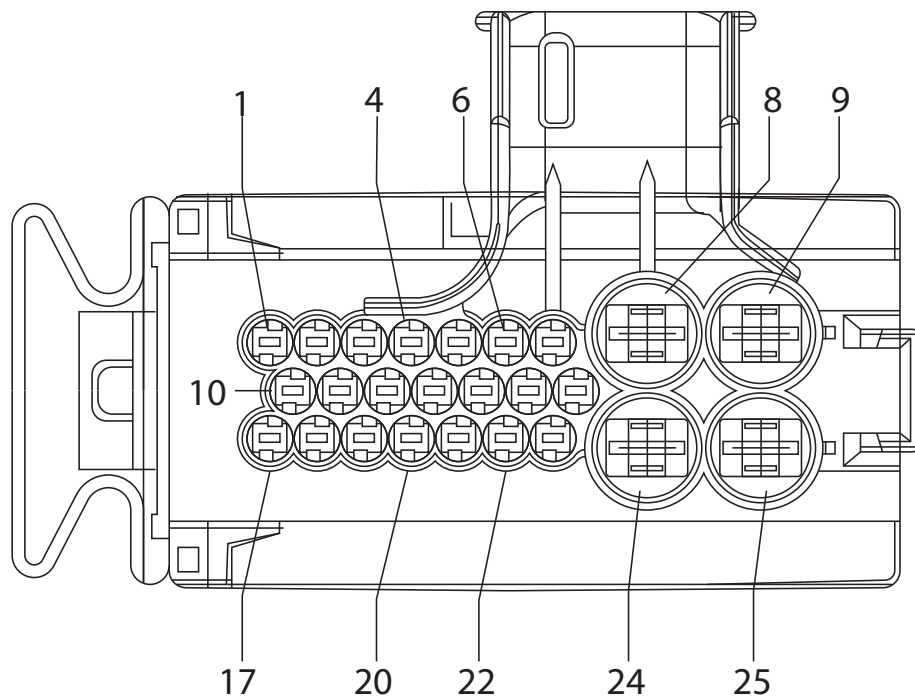

Connector on harness side.

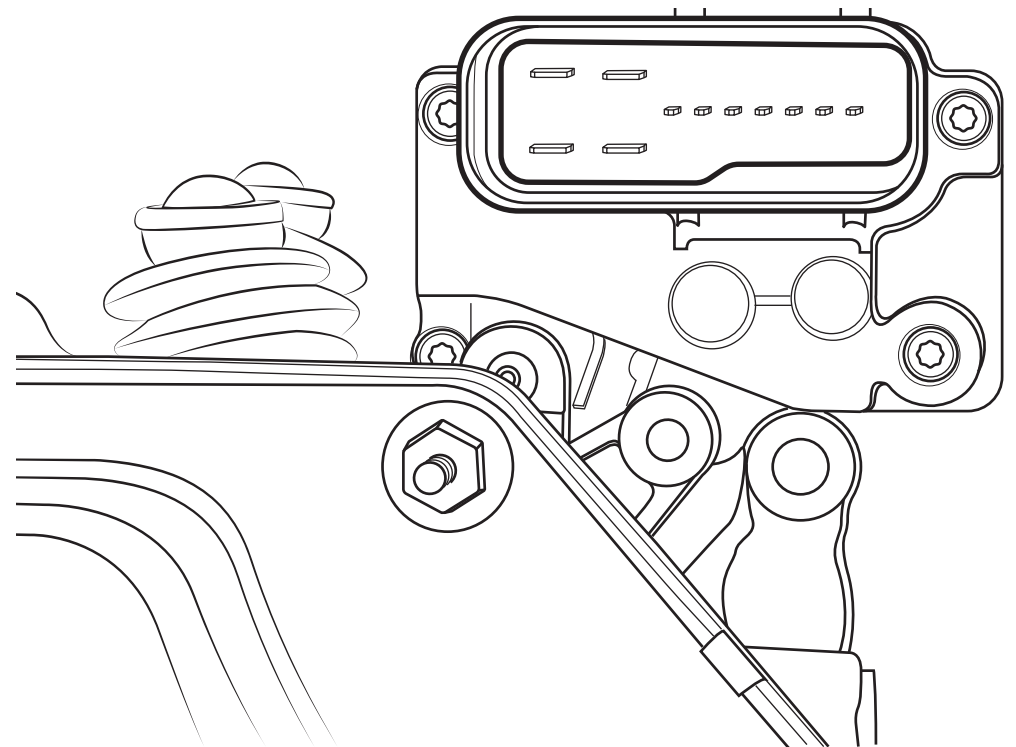

Connector on DSG 7 side.

ELECTRIC SCHEMATIC

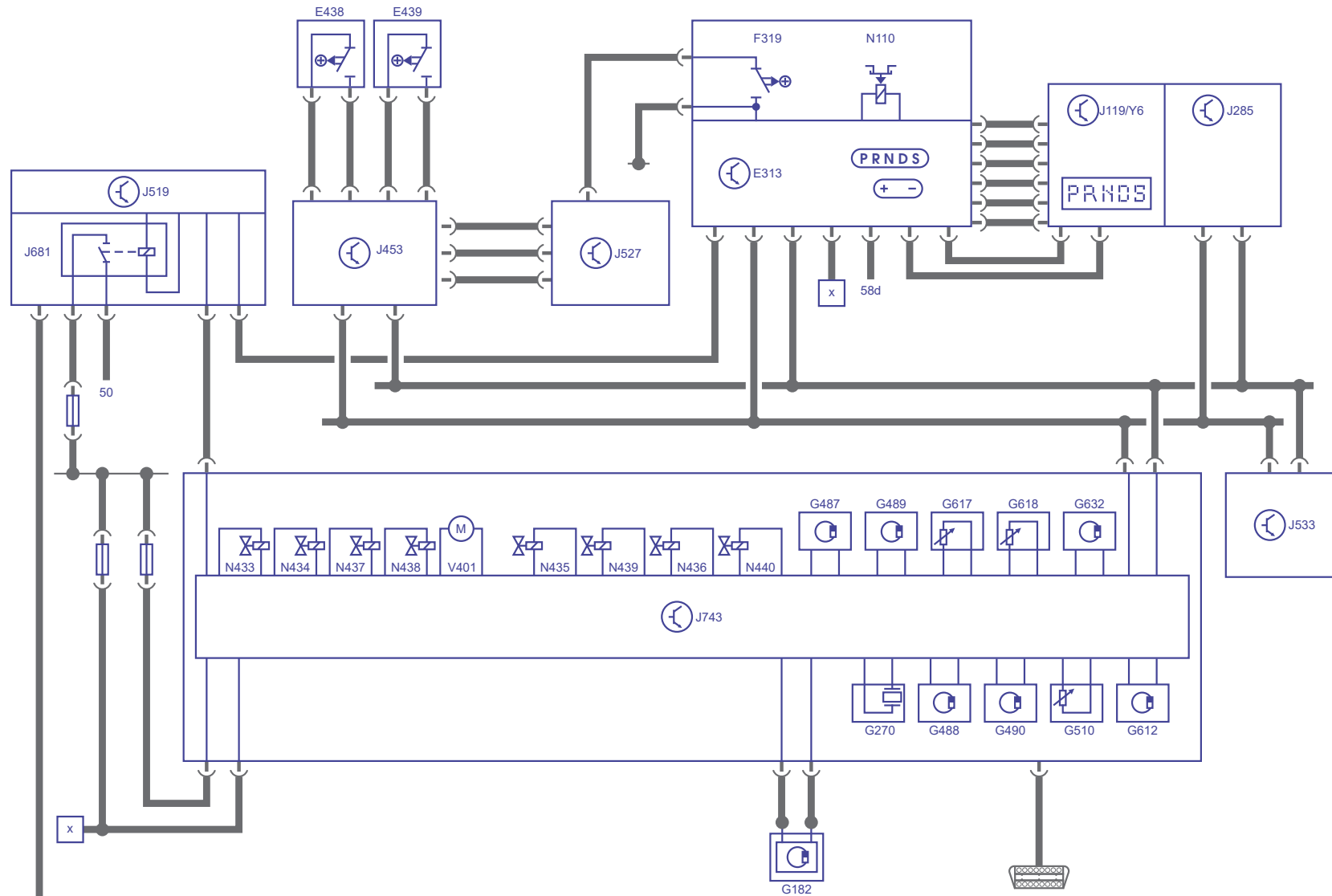

GENERAL OPERATION



The DSG 7 gearbox is an automatic double clutch gearbox. DSG stands for "Direktschaltgetriebe" or "Direct Shift Gearbox" and the 7 indicates that there are seven forward gears. For this gearbox the designation 'DQ200' is also used. The Q ('Quermotor') indicates that this gearbox is used for transverse engines.

Mechanically, the DSG 7 gearbox can be described as a manual gearbox with two dry plate clutches, two drive shafts (input, primary) and three output shafts (secondary).

An electronically controlled hydraulic control (Mechatronic) ensures that the gearbox can operate fully automatically. As an option, an additional manual shifting option can be selected (Tiptronic).

A dual mass flywheel connects the crankshaft of the engine with the drive plate that rotates in line with the crankshaft. Two dry clutches on either side of the drive plate rotate independently of each other around the same shaft and each drives its own drive shaft by means of a 'spline shaft'. Drive shaft 1 rotates inside the hollow drive shaft 2.

On **drive shaft 1** are the gears for 1st, 3rd, 5th and 7th gear. The gears for the 2nd, 4th, 6th and reverse gear are on **drive shaft 2**.

From drive shaft 1, the gears for 1st and 3rd gear are driven on the first output shaft and the gears for 5th and 7th gear are driven on the second output shaft. From drive shaft 2, the gears for 2nd and 4th gear are driven on the first output shaft and the gears for 6th and reverse gear are driven on the second output shaft. Sprocket R1 on the second output shaft drives the third output shaft for reverse gear via sprocket R2. All three output shafts drive the differential gear.

Because the gears for 1st, 3rd, 5th and 7th gear are on **drive shaft 1** and the gears for 2nd, 4th, 6th gear on **drive shaft 2**, shifting takes place from one drive axle to the other when shifting to the next gear.

The next gear is already engaged on the corresponding output (main) shaft. When shifting gears, the clutch to the drive shaft of the 'old' gear is decoupled in one smooth movement and the clutch to the drive shaft of the 'new' gear is coupled in one smooth movement. So there is an overlap in the drive through both gears. In addition, when shifting up, the engine torque is slightly lowered, while when shifting down, the engine torque is slightly increased. All in all, this ensures a fast and smooth shifting action with no noticeable interruption in propulsion.

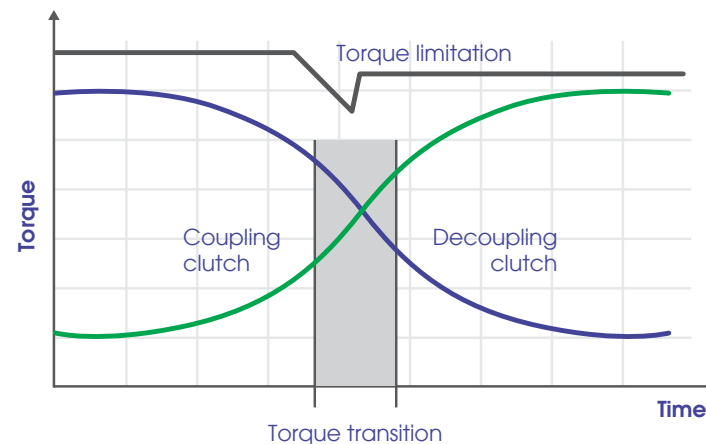

Schematics of the DSG 7 gearbox

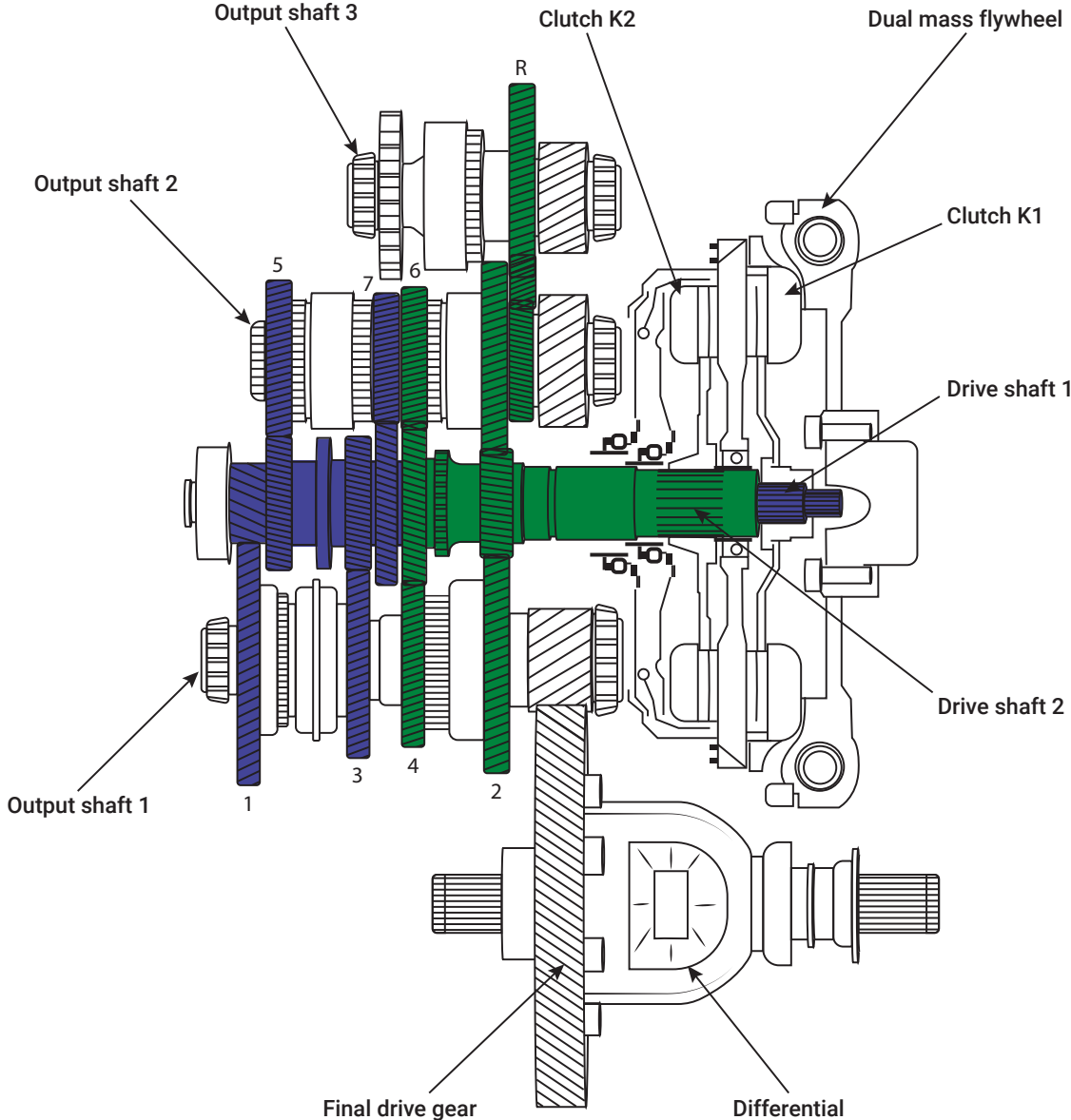

THE MECHATRONIC IN DETAIL

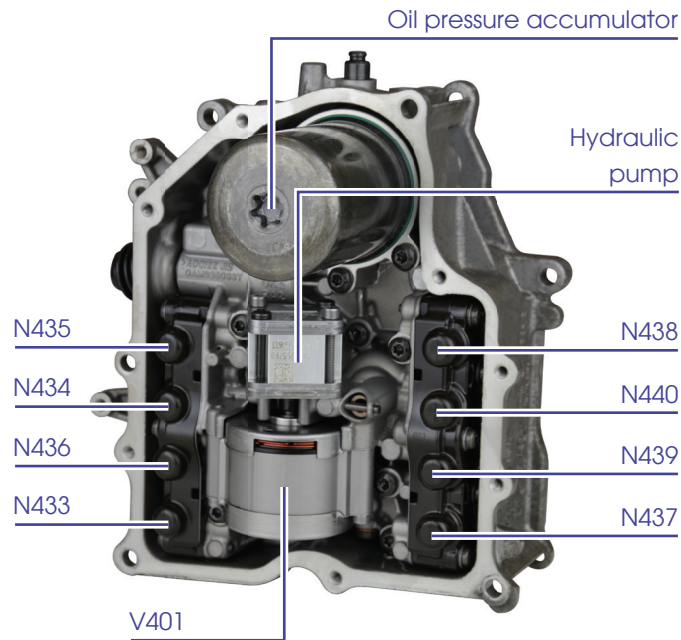

system pressure in the control unit remains between 40 and 60 bar.

The electro-hydraulic control unit has eight control valves. Valves N433, N434, N437 and N438 operate the shift forks that engage the gearwheels on the output shafts. Control valves N435 and N439 operate both clutches. Valves N436 and N440 regulate the required system pressures in both gearbox halves:

Control valve N436 controls the pressure in gearbox half 1 for valve N435, which controls clutch K1, for valve N433, which controls the shift fork for 1st and 3rd gears, and for valve N434, which controls the shift fork for 5th and 7th gears.

Control valve N440 controls the pressure in gearbox half 2 for valve N439, which controls clutch K2, for valve N437, which controls the shift fork for 2nd and 4th gears, and for valve N438, which controls the shift fork for 6th and reverse gears.

Actuator	Function
N433	Shift valve for shifting 1st and 3rd gears
N434	Shift valve for shifting 5th and 7th gears
N435	Pressure control valve for clutch K1
N436	Pressure control valve for system pressure in gearbox half 1
N437	Shift valve for shifting 2nd and 4th gears
N438	Shift valve for shifting 6th and reverse gears
N439	Pressure control valve for clutch K2
N440	Pressure control valve for system pressure in gearbox half 2
V401	Hydraulic pump motor

Shifting, clutch activation and clutch de-activation are controlled from the central gearbox control unit, the Mechatronic (J743). This consists of an electronic control device and an electro-hydraulic control unit.

The Mechatronic is attached to the gearbox and has its own oil circuit, independent of that of the actual gearbox. This means that the hydraulic part of the DSG 7 DQ200 has its own oil pump, valves and cylinders. These cylinders are directly connected to the shift forks and the clutch levers.

The electro-hydraulic control unit incorporates an electrically driven V401 hydraulic pump and an oil pressure accumulator, which together ensure that the

THE TCU IN DETAIL

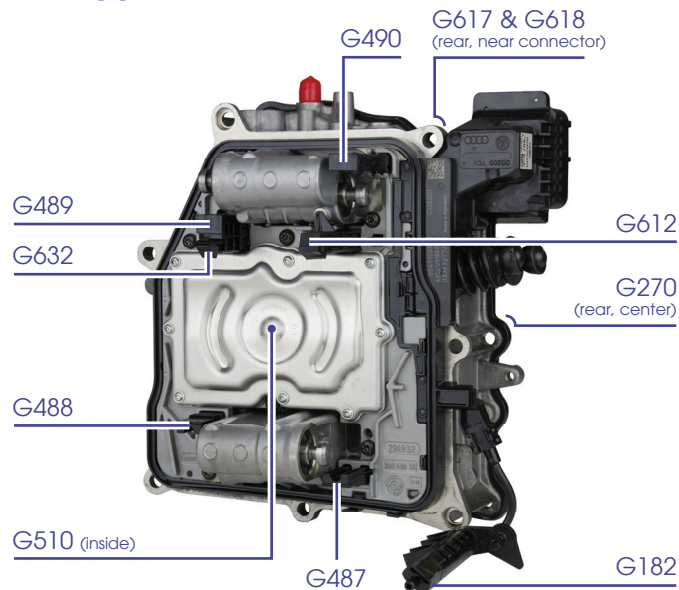

Sensor	Function
G182	Speed sensor input shaft gearbox
G270	Pressure sensor for the hydraulic pressure of the gearbox
G487	Position detection sensor for the selector fork for 2nd and 4th gears
G488	Position detection sensor for the selector fork for 1st and 3rd gears
G489	Position recognition sensor for the shifting fork for 5th and 7th gears
G490	Position detection sensor for the selector fork for 6th and reverse gears
G510	Gearbox oil temperature sensor in the electronic control unit
G612	Speed sensor for drive shaft 2
G617	Clutch path sensor for clutch K1
G618	Clutch path sensor for clutch K2
G632	Speed sensor for drive shaft 1



Always check the three speed sensors for metal particles. If there is any contamination, check the gearbox thoroughly for mechanical wear/damage. Then clean the sensor

In order to provide the Mechatronic with the necessary information, the TCU receives information from a number of sensors. The overview alongside shows exactly what information is received. Almost all of these sensors are built into the Mechatronic. However, speed sensor G182 is located outside the Mechatronic.

The TCU not only receives the necessary information from its own sensors but also exchanges information with the various measuring and control devices in the car via the CAN bus, for example:

E313	Gear selector lever
J104	ABS (with EDL) control device
J248	Control unit for diesel direct injection
J285	Control unit for display instrument panel
J453	Control unit for multifunction steering wheel
J519	Control unit for electrical installation
J527	Control unit for steering column electronics
J533	Diagnostic interface for data bus
J623	Engine control unit for diesel engines

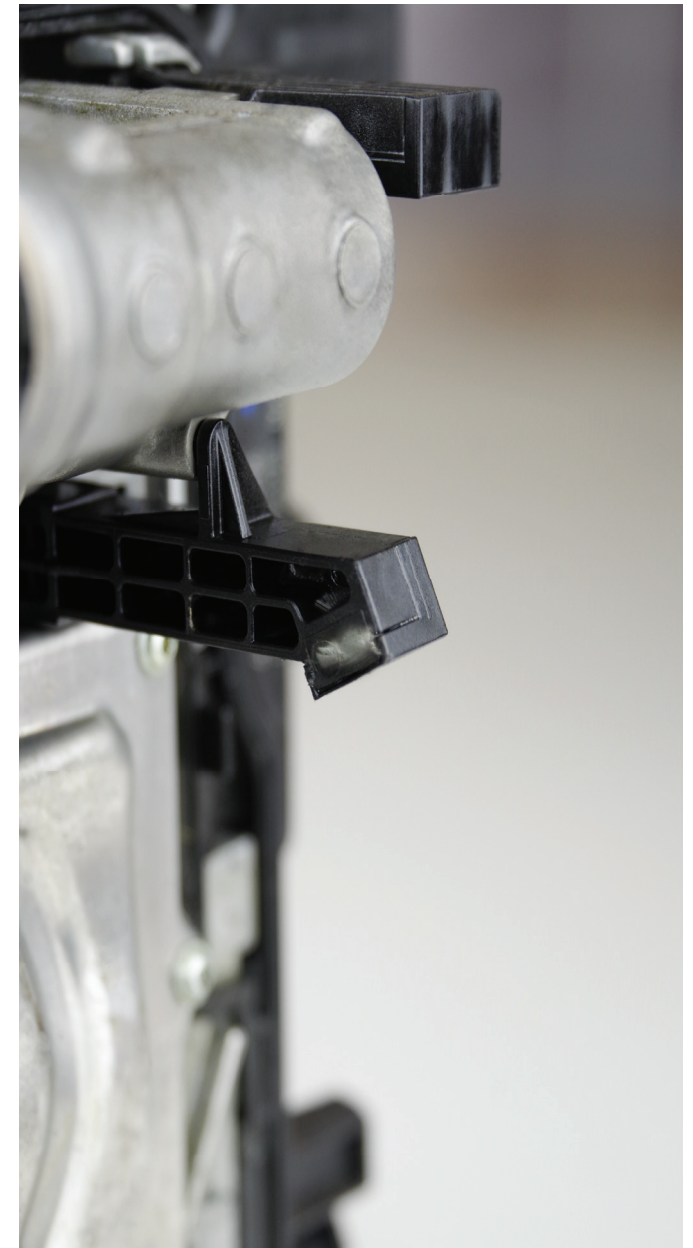

REMOVING THE MECHATRONIC

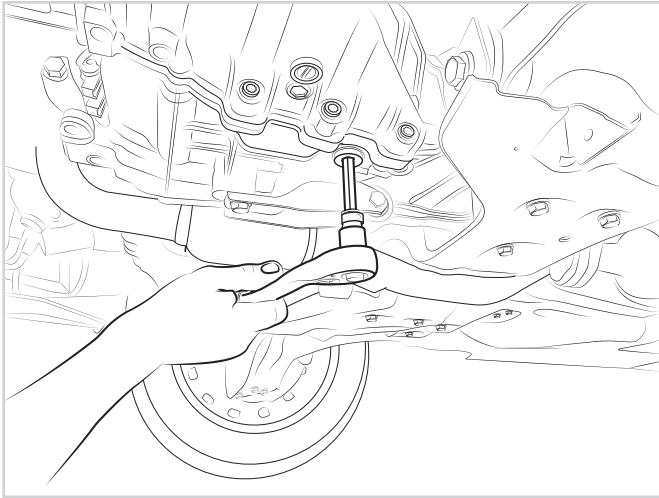

Prior to disassembly

1. Set the selector lever to "P".
2. If there is a radio with a radio code, make sure that the radio code is known before disconnecting the battery.
3. Turn off the ignition and disconnect the battery ground lead.
4. Use the VAS or ODIS diagnostic test to set all gear shifting mechanisms to "neutral". If such a diagnostic test is not available, it can also be done manually. We will describe this in the last step.
5. Drain the transmission oil from the gearbox through the bottom plug.
6. Reinstall the plug. Tightening torque: 30 Nm.

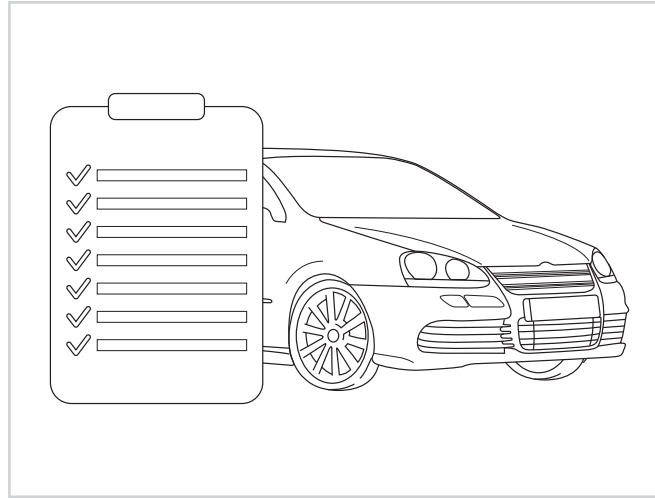

Removing the surrounding parts

1. Remove the battery.
2. Remove the battery support: the support is secured with 3 large bolts.
3. Remove the starter motor.
4. Pull the plug off the Mechatronic and remove the cable supports.



ATTENTION:

Due to the high number of cars in which the DSG 7 Mechatronic is mounted, this chapter only focuses on the steps that are universally applicable. For specific instructions, always refer to the manufacturer's official documentation.

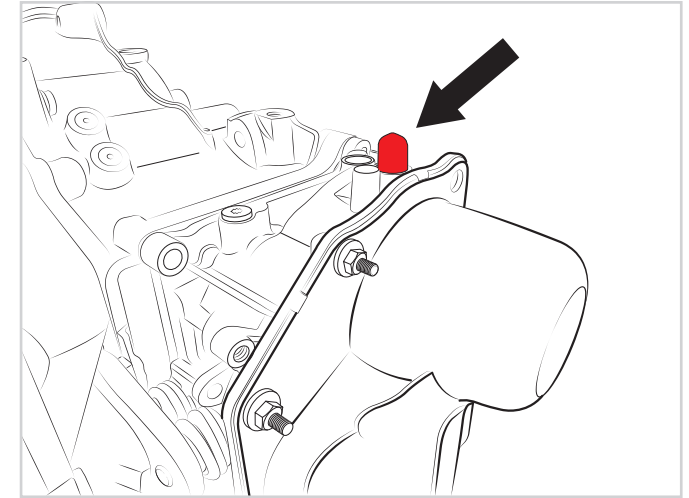

Sealing the Mechatronic

1. Now remove the breather plug (see figure) and seal the opening **oil-tight**.



ATTENTION:

The above step is very important, because the oil level in the Mechatronic cannot be checked and therefore cannot be topped up correctly. No hydraulic oil should leak out of the Mechatronic at all, not even after disassembly!

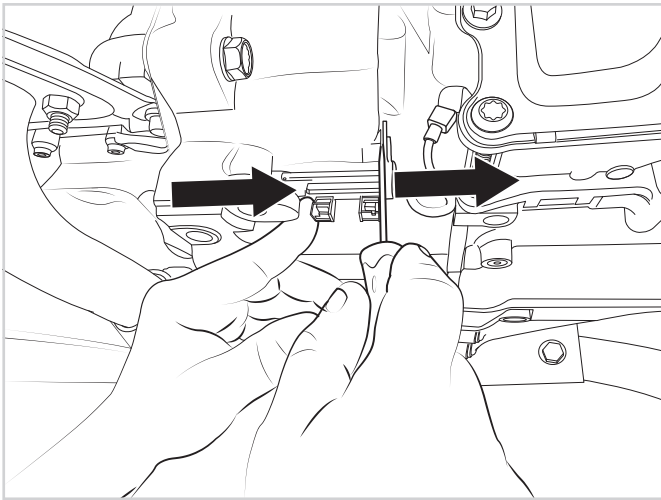

Releasing the control arms from the tappets

1. Carefully push the speed sensor out of the housing with a screwdriver.

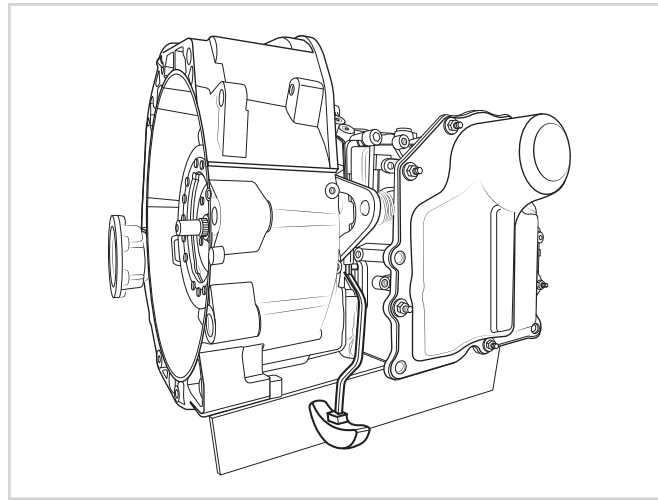

2. Insert the mounting lever T10407 (original Volkswagen AG tool) to the right of the control arms.
 3. Slide the mounting lever all the way through until the rear end is against the gearbox housing: the groove of the mounting lever must be in a straight line with the edge of the housing.

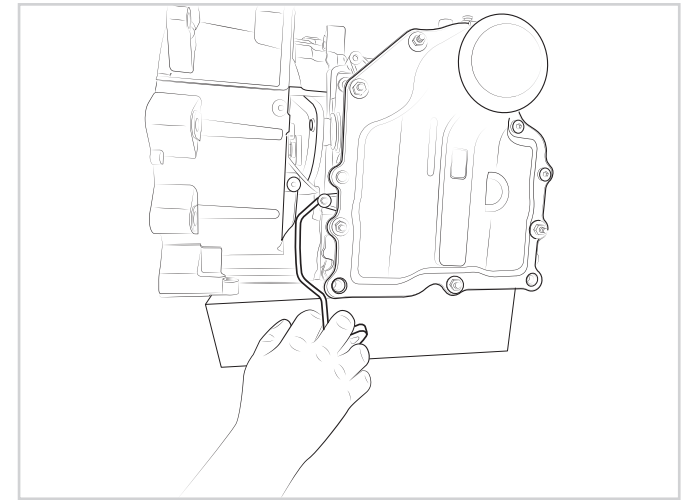

4. Now slowly turn the mounting lever anticlockwise to release the control arms from the tappets.



When turning, apply some downward force to the mounting lever to prevent slipping.



ATTENTION:

Then leave the mounting lever in exactly the same place. Removing it may have a negative effect on the clutch adjustment mechanism.

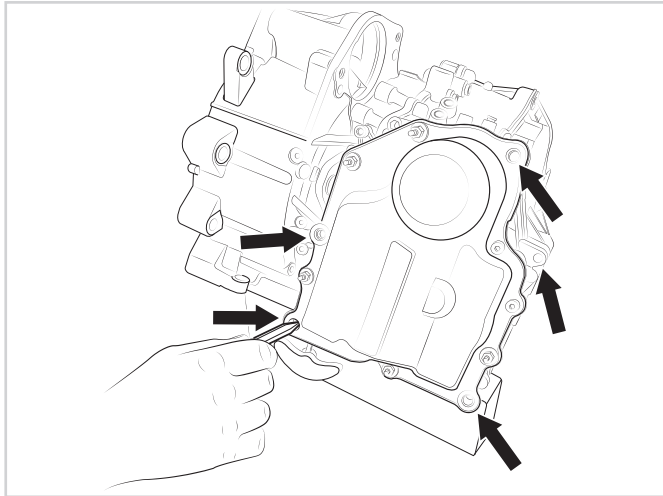

Removing the Mechatronic

1. Remove only the 7 bolts that hold the Mechatronic in place, see arrows in the illustration: 4x long, 3x short, Torx 45.
2. Remove the Mechatronic from the gearbox in a straight line and keep it upright so that no oil can escape from the Mechatronic.

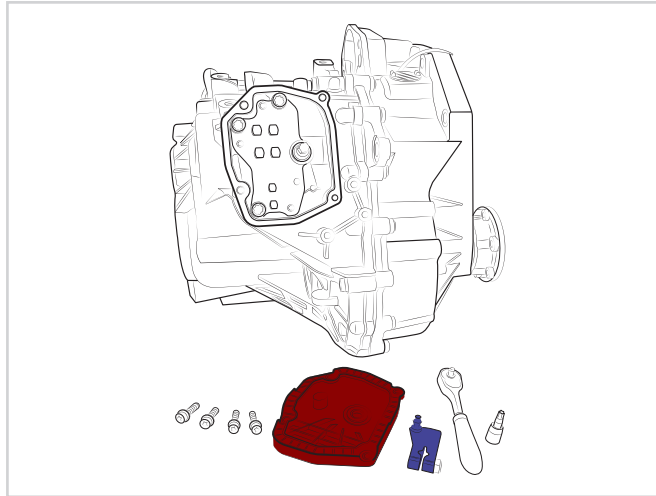

Set the gearshift mechanisms to "neutral"

If the mechatronic is stuck and cannot be removed, secure it again with a bolt and follow the next steps:

1. Disconnect the shift cable from the gearbox.
2. Remove the shift fork (purple).
3. Remove the cover (red).
4. Now push the selector fork (purple) aside by hand.
5. It is now possible to remove the Mechatronic.

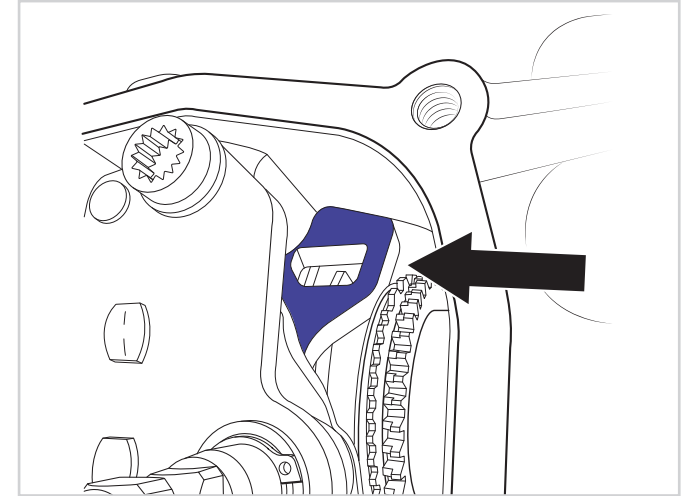

OFFER FOR REMANUFACTURE

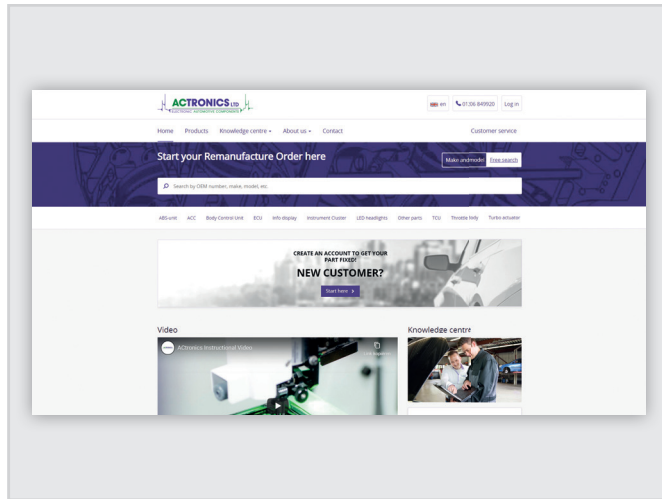

Sign up online

Go to www.actronics.co.uk and click on "Free search".

- › Then enter "DSG 7" and the product will immediately appear on the screen.
- › Click on "View product" and follow the dropdown menu.
- › You have now selected the right product.
- › Now click on "Next" and log in to complete the registration.
- › Print the [Remanufacture Order Form](#) after registration.

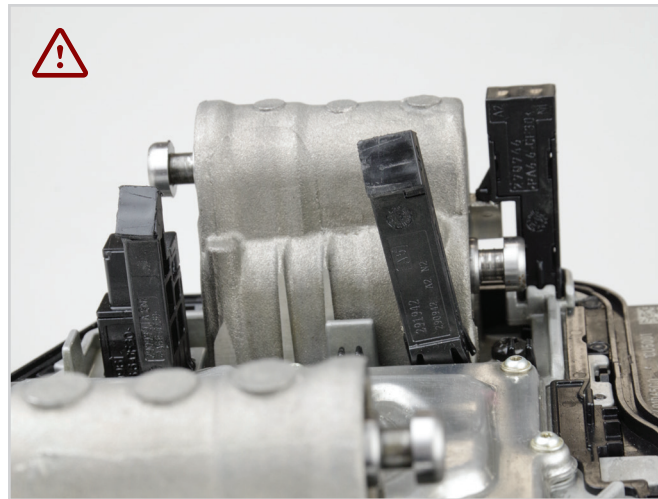

Shipping

To prevent transport damage, the Mechatronic of the DSG 7 must be sent in specially designed transport packaging. Before sending the Mechatronic, please contact our Customer Service: 01206 849920. They will then send you the transport packaging free of charge.

Pack the Mechatronic in such a way that absolutely no oil can leak out of the unit during transport. It is very important that the oil level is maintained at all times. Save the vent cap. This is necessary when the Mechatronic is placed back in the vehicle.



IMPORTANT:

Enclose the printed Remanufacture Order Form with the product in the transport packaging. This is crucial for identification upon receipt.

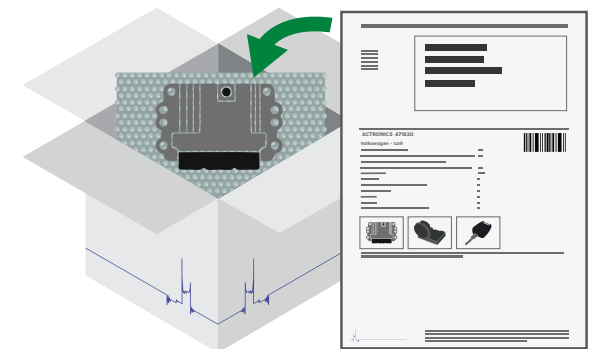

INSTALLING THE MECHATRONIC AFTER REMANUFACTURING

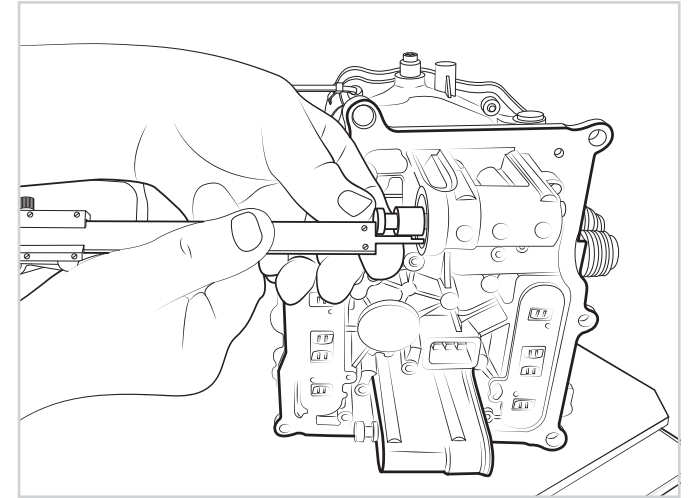
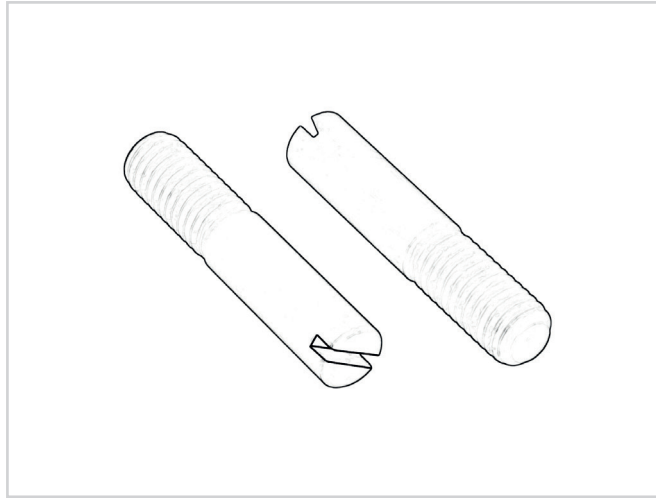
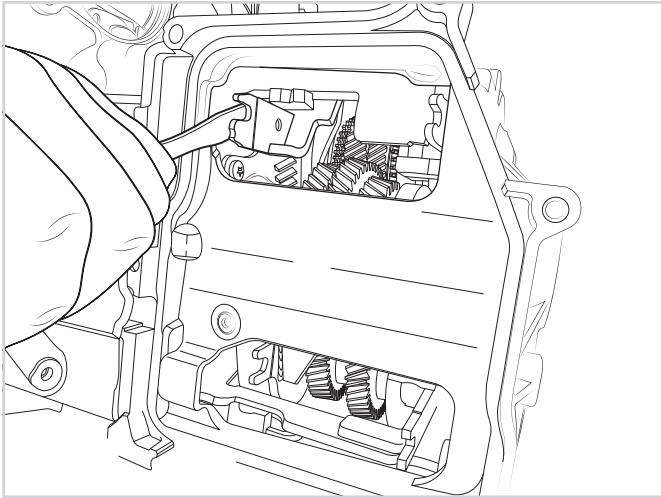

Prior to assembly

1. Check that all shift forks (4x) are still in neutral position. Each fork has 3 positions: gear, neutral, gear. All forks must therefore be in the middle position.
2. Insert 2x guide bolt T10406 (original Volkswagen AG tool).
3. Check that the 4 tappets of the Mechatronic all protrude by 25 mm, see dimension "a" in the illustration.
4. Check that the seal of the Mechatronic is undamaged and leak-proof.



If the Mechatronic is remanufactured by us, we always send a tool (in the form of a black bushing) to help with point 3. This tool can be slid over the tappet. The tool will then always depress the tappet to the correct length.

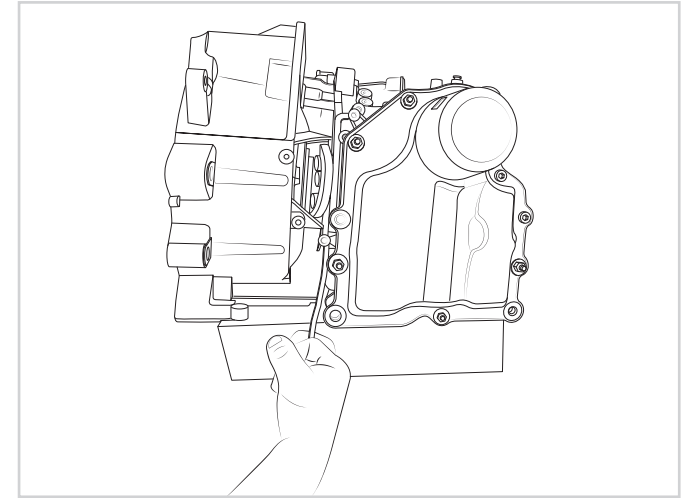
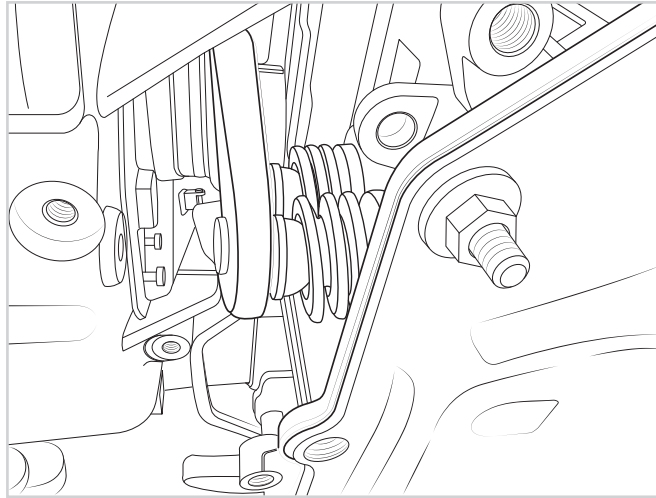
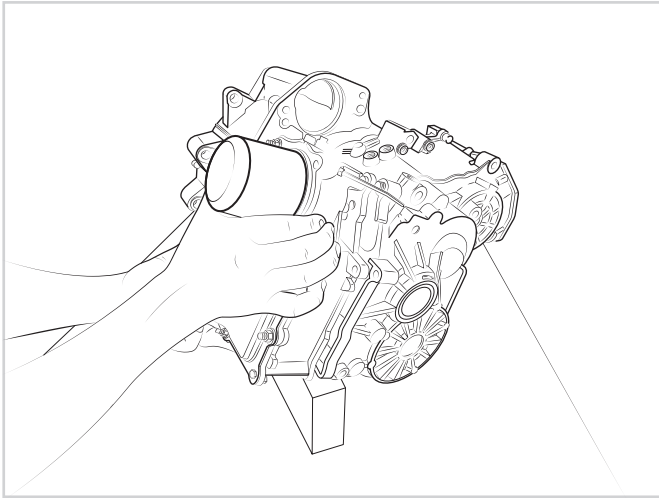

Mounting the Mechatronic

1. Place the Mechatronic gently over the guide bolts into the correct position.
2. Tighten the Mechatronic by **hand-tightening** the 7 bolts.
3. Remove the guide bolts.
4. Check the position of the clutch cylinders in relation to the clutch levers. Incorrectly attached clutch cylinders can damage the Mechatronic.
5. Tighten the 7 fixing bolts crosswise. Tightening torque: 10 Nm.
6. Turn the mounting lever clockwise and remove it from the shift mechanism.



ATTENTION:

It is important that the clutch cylinders engage correctly in the clutch levers.

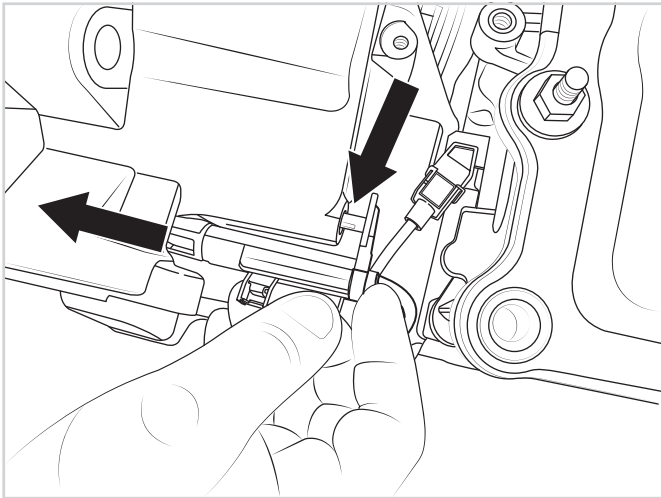

7. Put the speed sensor back in position. The clip must not be broken and the sensor must be completely attached to the housing as shown by the arrows in the illustration.

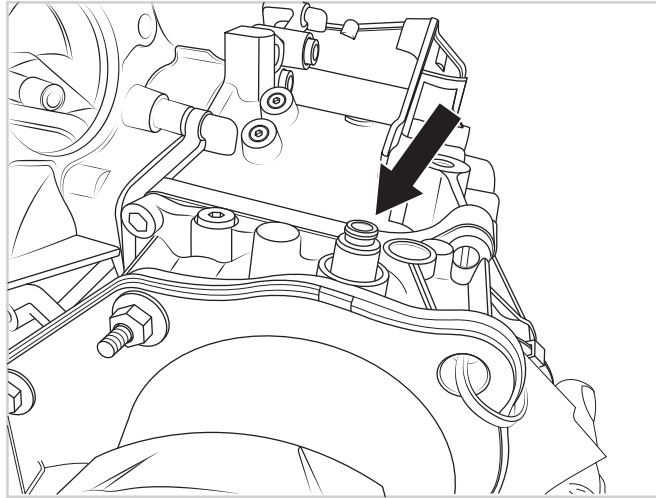

8. Remove the bleed plug and replace the original bleed plug.
9. Click the plug back onto the Mechatronic.
10. Refit the cable supports

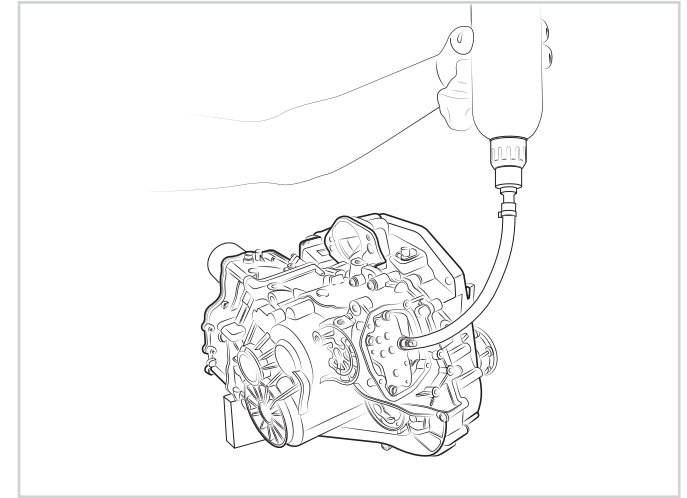

Filling with gearbox oil

1. First follow the steps of "Setting the gearshift mechanisms to "neutral"" in "Removing the Mechatronic".
2. Pour exactly 1.9 litres of the prescribed gearbox oil into the opening by the fork.
3. Also apply some oil to the O-ring before replacing the cover plate.

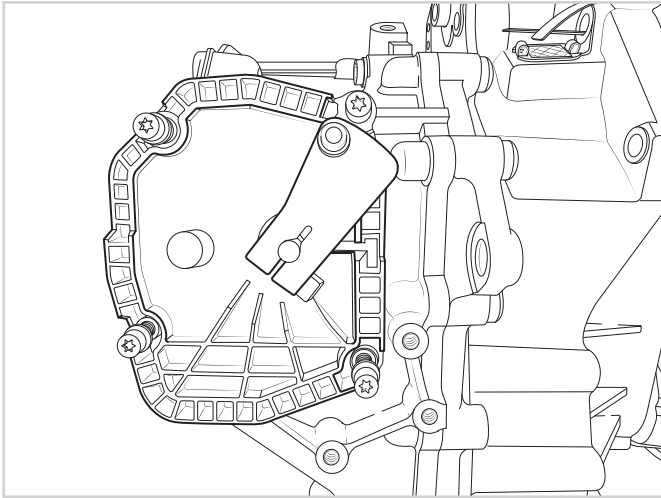

Mounting the cover and surrounding parts

1. Refit the cover and tighten the screws. Tightening torque: 8 Nm.
2. Refit the fork and tighten the screws. Tightening torque: 15 Nm.
3. Secure the shift cable to the fork by clicking it onto the ball.
4. Insert a **new** mounting clip to secure the shift cable to the mounting point (see arrow).
5. Refit the starter motor.
6. Refit the battery support.
7. Insert the battery.

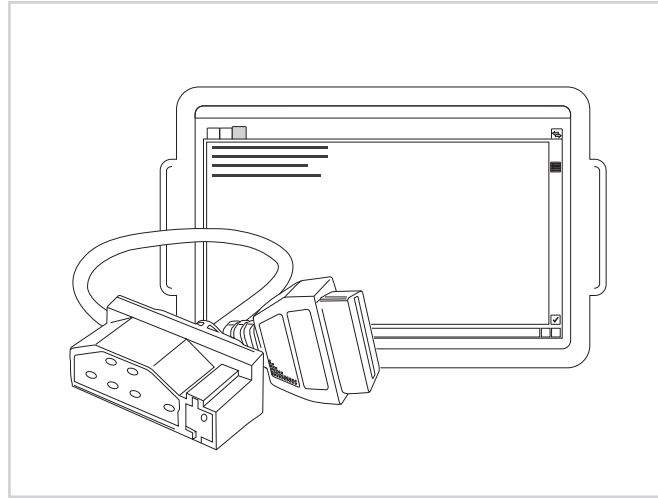

Programming the basic Mechatronic settings

There are several diagnostic testers in circulation that can all perform the basic setting. For example: VAS, ODIS and VCDS. The aforementioned diagnostic testers all use a program with easy to follow steps.

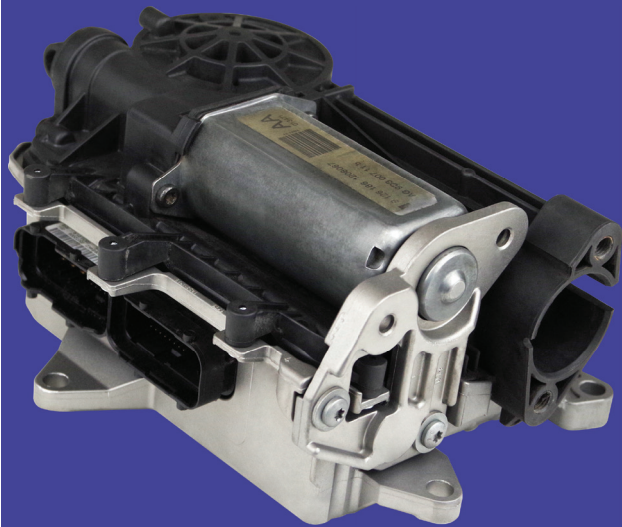

BOSCH EASYTRONIC F13/F17 MTA

Manual gearboxes are frequently robotised. Which is actually quite a nice solution because you can basically build any car with the same manual gearbox. The only thing that needs to be added to turn it into an automatic is a piece of mechatronics that controls the clutch and gears, such as, for example, the Easytronic F13/5 from Bosch. Problem solved!



VAUXHALL AGILA A 2000-2007

Bosch Easytronic - F13/F17 MTA



VAUXHALL ASTRA G 1998-2004

Bosch Easytronic - F13/F17 MTA



VAUXHALL ASTRA H 2004-2010

Bosch Easytronic - F13/F17 MTA



VAUXHALL ASTRA J 2009-2015

Bosch Easytronic - F13/F17 MTA

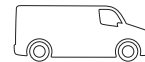

VAUXHALL COMBO C 2001-2011

Bosch Easytronic - F13/F17 MTA



VAUXHALL CORSA C 2000-2006

Bosch Easytronic - F13/F17 MTA



VAUXHALL CORSA D 2006-2014

Bosch Easytronic - F13/F17 MTA

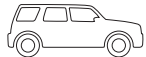

VAUXHALL MERIVA A 2003-2010

Bosch Easytronic - F13/F17 MTA

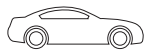

VAUXHALL TIGRA TWINTOP 2004-2009

Bosch Easytronic - F13/F17 MTA

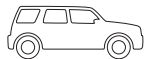

VAUXHALL SIGNUM 2003-2008

Bosch Easytronic - F13/F17 MTA



VAUXHALL VECTRA C 2002-2008

Bosch Easytronic - F13/F17 MTA

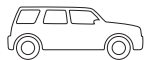

VAUXHALL ZAFIRA B 2005-2011

Bosch Easytronic - F13/F17 MTA

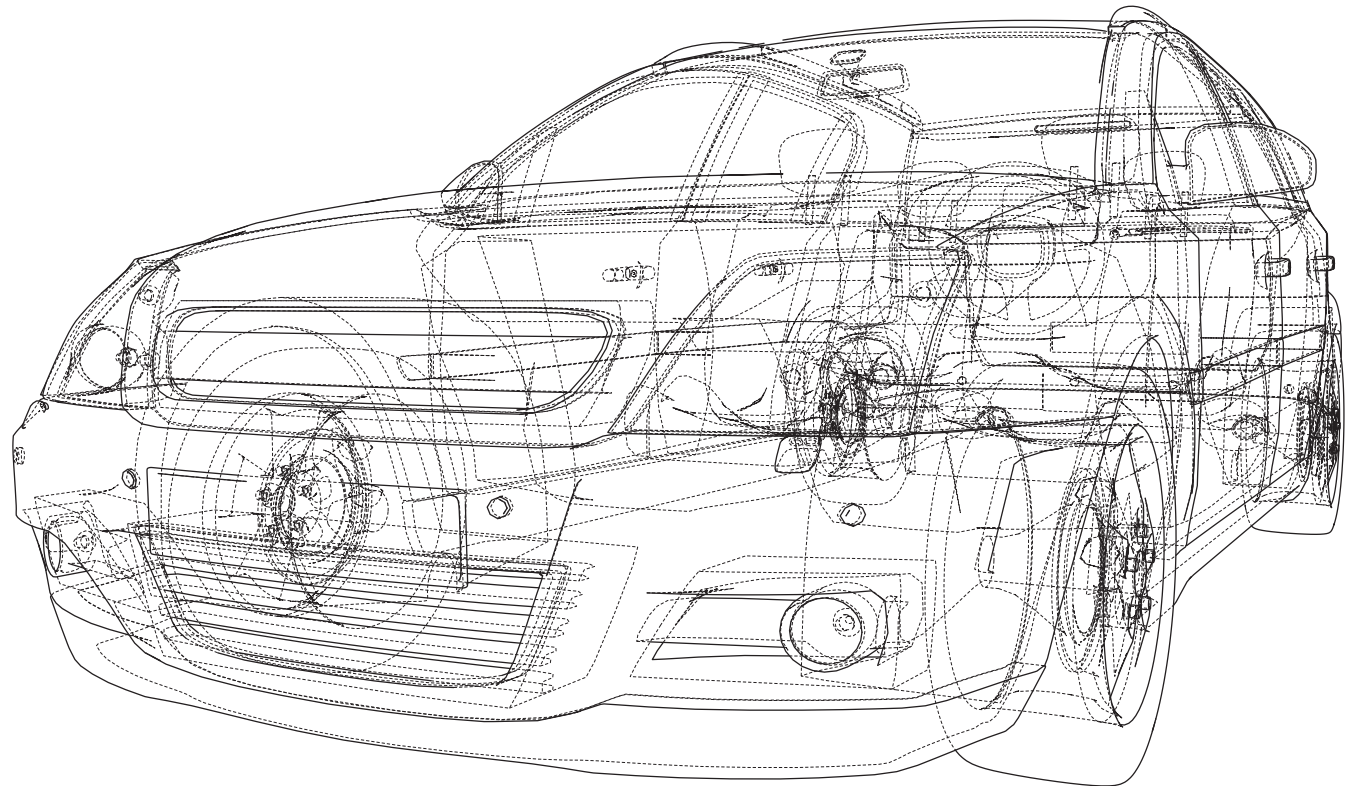

KNOWN COMPLAINTS

- › “F” appears in the display
- › The car does not start
- › The gearbox doesn’t shift at all or doesn’t shift smoothly
- › The clutch does not operate smoothly

CAN BE REMANUFACTURED

OBD II	Description
P1607	Position control error coupling actuator
P1609	Position sensor clutch actuator
P1700	Gearbox steering system operating problem
P1723	Selector delivers data via unused cable
P1728	Shift motor mechanical failure
P1729	Shift motor electrical failure
P1730	Fault control gearbox
P1735	Gearbox parameters not learned
P1740	Shift motor malfunction (often in combination with P1728)



IMPORTANT:

Some malfunctions may be caused by worn contacts on the gear selector lever. By this we mean the contact points of the different positions (“P”, “N”, “R” and “D”).

REMANUFACTURE MAY BE POSSIBLE ADDITIONAL DIAGNOSIS REQUIRED

OBD II	Description
P1725	Shift motor sensor supply voltage
P1726	Select motor sensor supply voltage

These error codes often appear when a problem occurs in the Easytronic system wiring. Check in particular the wiring harness between the shift motors and the Mechatronic.

Is the wiring really OK? If so, then the shift motor may really be defective. In this case, the Mechatronic must still be remanufactured.

If in doubt, please contact our Customer Service.

Telephone: 01206 849920



CANNOT BE REMANUFACTURED

OBD II	Description
P1734	Touchpoint adaption not done
P1735	Gearbox parameters not learned

These error codes only appear if the learning process has not been completed correctly. Without the presence of other error codes, this means that the learning process simply has to be repeated.

OBD II	Description
P1703	Brake light switch signal not in nominal range

This error code also causes an "F" in the display and the car cannot be started, but in this case the problem really lies with the brake lights themselves. Think of moisture in the rear lights or a wire break. A defective reversing light switch or brake light switch can also activate this fault code.

OBD II	Description
P1733	Wrong variant configuration

There is an incorrect type of Easytronic built into the car. Pay close attention to the part numbers when exchanging.

PIN ASSIGNMENT FOR TCU CONNECTOR 1 (XC13/X68)

Pin 45	K-line
Pin 47	Power supply 12V +15
Pin 48	Ground 31
Pin 49	Power supply 12V +30
Pin 52	Brake light switch
Pin 54	CAN high
Pin 56	CAN low
Pin 57	Complement from pin 74 (interspersed with ecu check pulses)
Pin 61	Link CAN high
Pin 63	Link CAN low
Pin 74	Manual position = pulse train to 12V Auto position = pulse train to 10V
Pin 76	Data burst signal
Pin 77	Clock burst signal

The pin numbers in **bold** refer to the selector lever, which can be used to change gears manually if necessary. See also the wiring diagram for both types (2-wire or 4-wire)

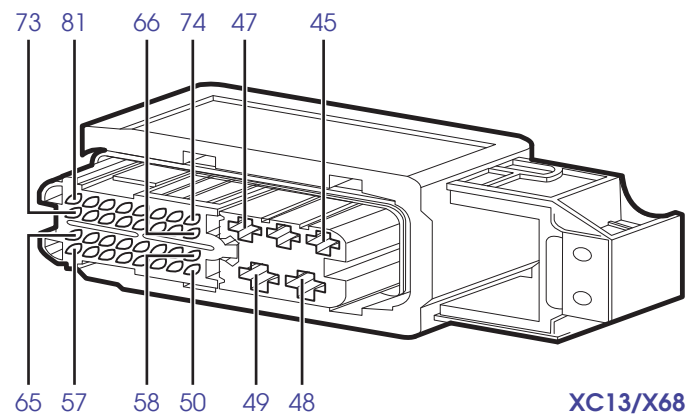

PIN ASSIGNMENT FOR TCU CONNECTOR 2 (XC14/X69)

Pin 106	Sensor input 2 (counter)
Pin 107	Sensor input 1 (direction)
Pin 108	Sensor input 2 (counter)
Pin 109	Sensor input 1 (direction)
Pin 114	Engine ground
Pin 115	Engine ground
Pin 116	Power supply 12V motor
Pin 117	Power supply 12V motor
Pin 118	Power supply 12V sensor
Pin 119	Power supply 12V sensor
Pin 120	Ground sensor
Pin 121	Ground sensor

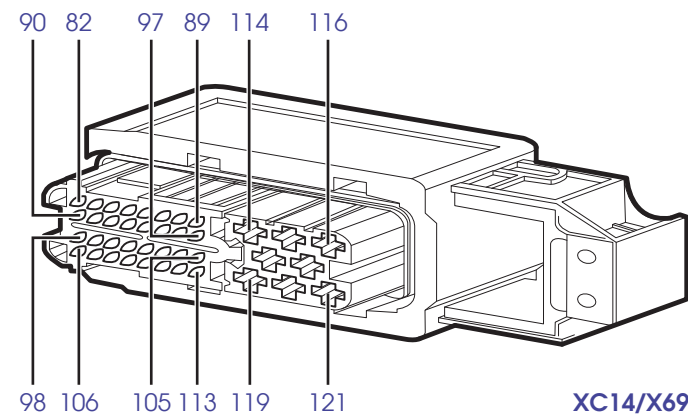

PIN ASSIGNMENT FOR THE CONNECTORS OF THE SHIFT MOTORS (XC25/X74 AND XC26/X75)

Pin 1	Power supply 12V motor
Pin 2	Ground sensor
Pin 3	Power supply 12V sensor
Pin 4	Sensor output 1 (direction)
Pin 5	Sensor output 2 (counter)
Pin 6	Engine ground

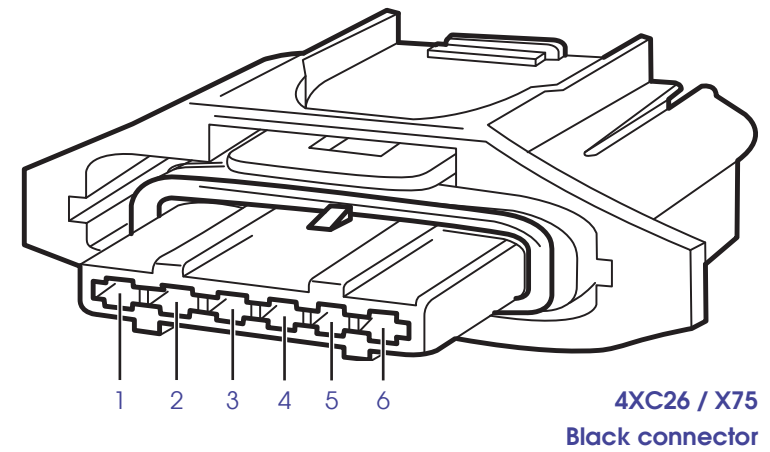
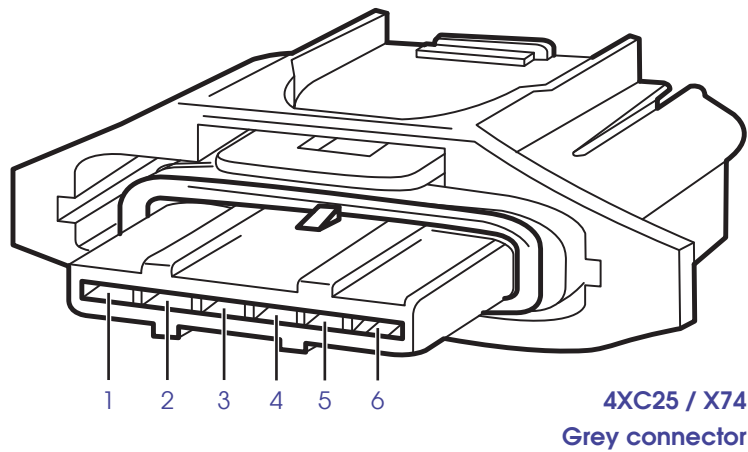

ELECTRIC SCHEMATIC

Easytronic with 2-wire lever (Corsa-D, 2012, A12XER)

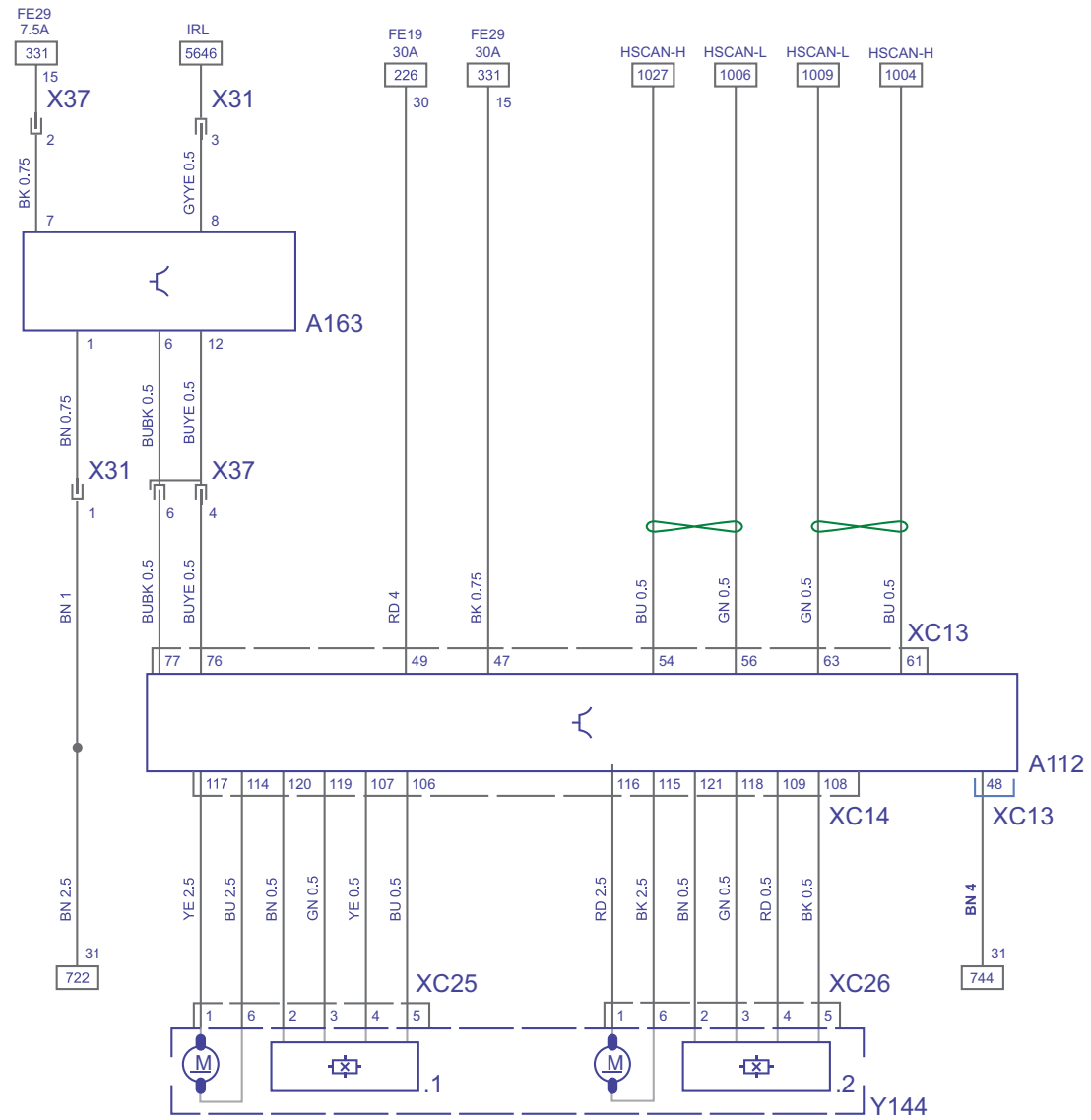

Easytronic with 4-wire lever (Corsa-C, 2002, Z12XE)

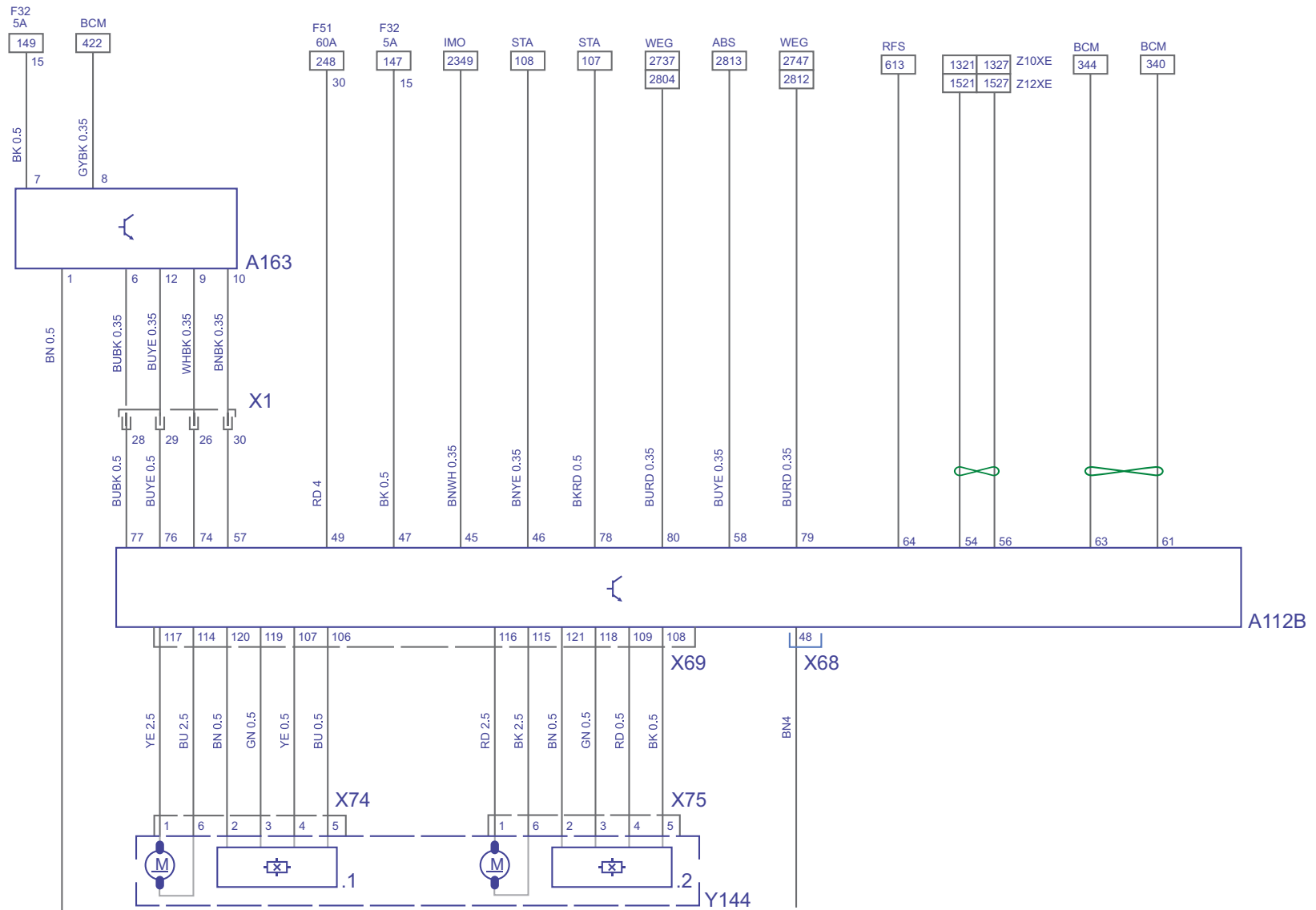

GENERAL OPERATION

The Easytronic F13 system is a so-called robotised gearbox, based on Vauxhall's manual five-speed gearbox with type number F13. This gearbox allows both automatic shifting and shifting with a selector lever.

For hydraulic disconnection, an electric motor (basically a large actuator) drives a hydraulic pump in the clutch actuator. The gearbox is shifted by two electric motors: the shift motors. In terms of power and size, the electric motors are comparable to wiper motors, for example.

The system is controlled from the TCU (Transmission Control Unit) which is mounted on the clutch actuator and is connected to the two shift motors and to the car's wiring via a wiring harness. The TCU receives the required signals via the CAN network.

Furthermore, this gearbox functions in the same way as a conventional manual gearbox: there is a clutch plate with a pressure group and the different gears are selected in the same way.

Possible causes of gearbox problems

A non-working robotised gearbox does not necessarily mean that the Mechatronic is faulty. We can identify three specific components that are more likely to fail:

1. Clutch system

A clutch is always subject to wear and tear, so it is wise to check the clutch and the pressure group before focusing on the rest of the gearbox. Because the clutch is operated automatically, the driver does not notice that the clutch is starting to wear out or not working as well. To the layman, the mechanism seems to be "suddenly" faulty.

2. Hydraulic fluid

There are many cases where the system has not been maintained for years and where extensive flushing and bleeding has completely solved all problems. The flushing and bleeding of the hydraulic circuit has even more advantages: possible malfunctions of the clutch actuator can be detected relatively easily (see also "The Mechatronic in detail"). This is because the bleeding procedure is so extensive that deviations can easily be spotted when operating the clutch actuator. It is not uncommon for this actuator to stop working properly.



3. Crankshaft sensor

Check carefully that the crankshaft sensor is doing its job all the time. Failing crankshaft sensors are commonplace. The common "F" will also appear in the display. You disassemble the entire gearbox and send the Mechatronic for repair, only to find out right at the end that a simple sensor is defective...



Complaints because of contaminated hydraulic fluid

Unfortunately, the periodic change of the hydraulic fluid is often neglected. What many people don't seem to think about is the fact that old/dirty hydraulic fluid can cause a lot of problems. Moving parts can cause excessive wear and therefore even leaks. It is also possible that certain channels may become clogged.

Sometimes these complaints can be solved by flushing and venting the system with a suitable diagnostic device. However, excessive wear may already have occurred.

THE MECHATRONIC IN DETAIL

The Mechatronic consists of three different parts: the Easytronic (the actual mechatronic part), the gear selector and the gear selector lever. Unfortunately, the name "Easytronic" is alternately used in various documentation for the system as a whole or just to indicate the mechatronic part. So pay close attention to what is meant!

Easytronic

Easytronic is the name of the mechatronics that control the clutch and the gear selector. The component consists of a TCU, a clutch actuator and an electric motor.

The most vulnerable part of the Easytronic is the clutch actuator. It is mounted in a plastic housing and can quickly start leaking. If you suspect that the clutch actuator is leaking, carry out the official bleeding procedure at all times (see later in this document). The clutch actuator will certainly leak if it is defective.

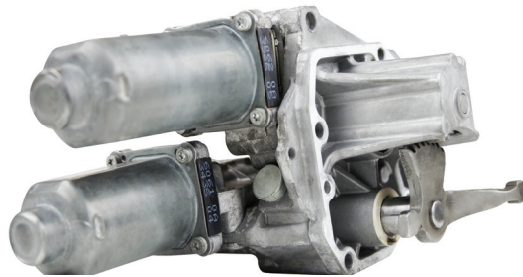
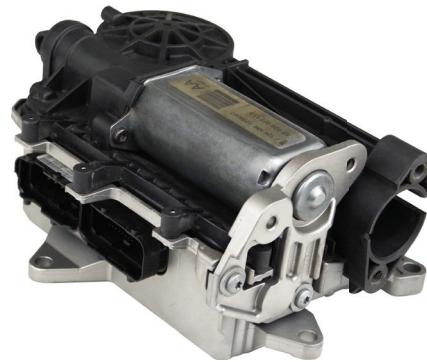

The gear selector

The gear selector consists of two electric shift motors. These shift motors are used to select the gears. As explained above, both motors are controlled by the TCU, which is located in the Easytronic.

The gear selector is still controlled in the "old-fashioned" way by the TCU.

This means that CAN messages are

not used, but power, ground and signals for direction and time are used. Because both signals are necessary to activate these "smart" electric motors, it is unfortunately not possible to connect power and ground to test the electric motors yourself.

The gear selector lever

The gear selector lever occasionally causes strange malfunctions. The mechanism is not entirely mechanical, as in a normal manual gearbox: the selector lever operates the gears by sending an electrical signal (so no CAN message!) to the TCU in the Easytronic. It is therefore more like a joystick. The signal sent depends on the position in which the selector lever is set. It often fails as soon as the contact points become worn out: the correct signal is no longer sent to the TCU.



Want to check if the signal is still being sent? Under "Pin assignment", you can see which pins in the TCU connector are intended for the gear selector lever. For example, the signal at pin 76 should change when the selector lever is moved from "N" to "R".

For the luxury (4-wire) versions:

A pulse train to 12V must be visible on pin 74 in manual mode. In automatic mode, the pulse train must drop to 10V.

DISENGAGING A STUCK GEARBOX

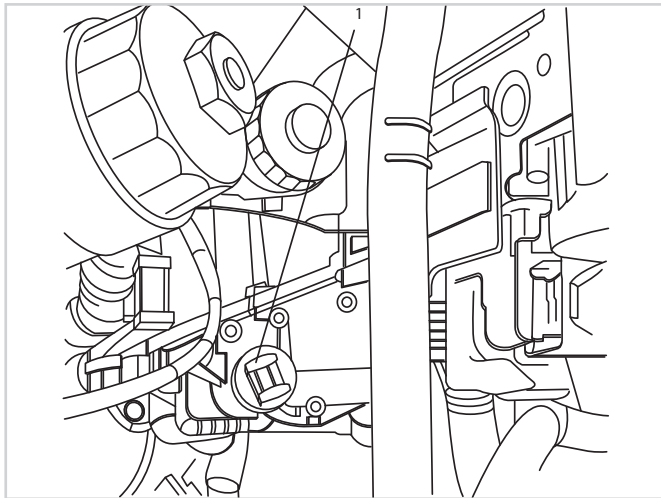

If the gearbox cannot be set to "N" – e.g. due to a malfunction or a flat battery – the clutch can be disengaged with an emergency control. To do so, follow these steps:

1. Turn off the engine and apply the parking brake.
2. Clean the area around the sealing cap "1" **thoroughly**.
3. Turn the sealing cap "1" and pull it upwards.

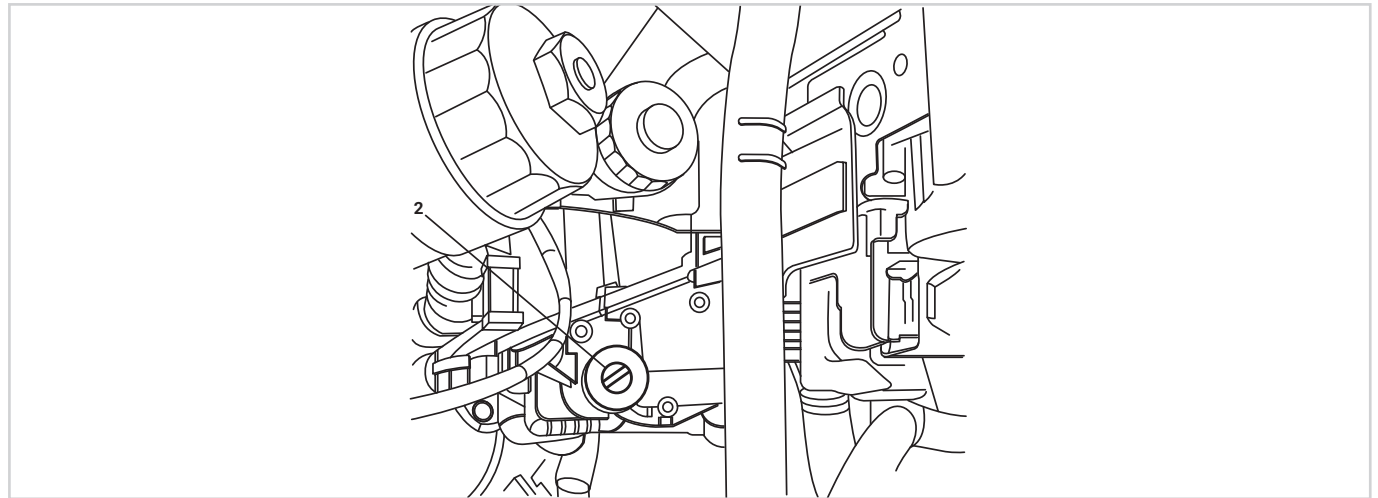

4. Turn the adjustment screw "2" clockwise (to the right) until resistance is felt. Do not turn any further, as this may damage the Easytronic.

The clutch is now free. The gearbox is no longer stuck and the car can be moved.

The emergency control must, of course, be switched off again after use. To do so, follow these steps:

1. Turn the adjustment screw "2" anticlockwise (to the left) until resistance is felt.
2. Install a **new** sealing cap "1".
3. Turn on the ignition and wait at least 5 seconds. The clutch will adjust itself during this time.

REMOVING THE EASYTRONIC COMPONENTS

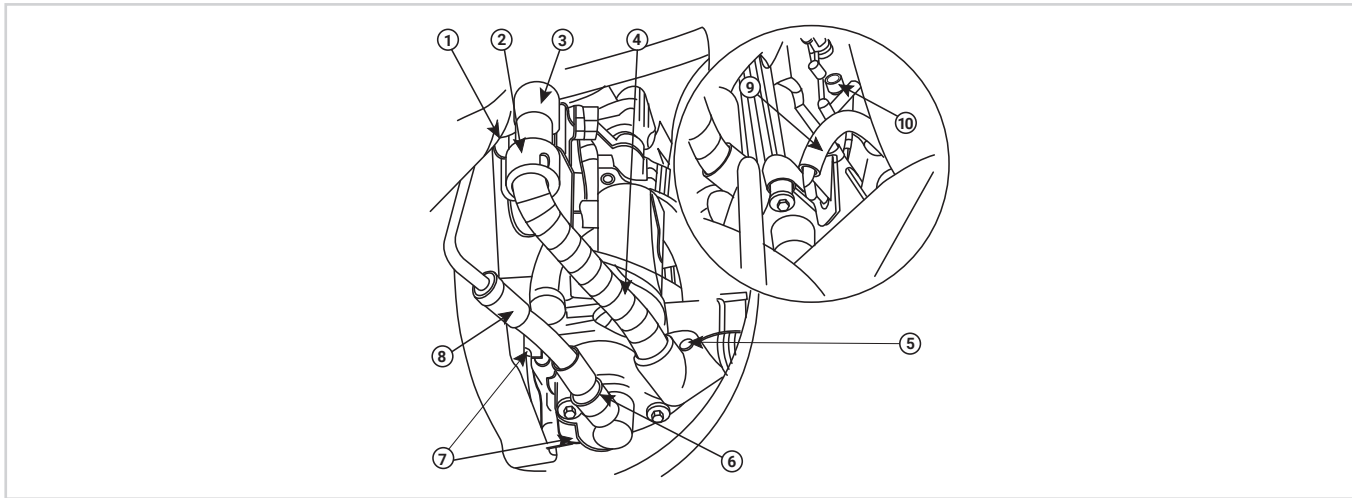

The Easytronic

1. Remove the cover of the hydraulic fluid reservoir.
2. Unlock and remove the wiring harness plug "3" from the Easytronic.
3. Remove the lower engine panelling (if applicable).
4. Disconnect the wiring harness holders "4" and "5". Unlock and remove the wiring harness plug "2" from the TCU.
5. Disconnect the brake fluid supply hose "9" and collect the escaping brake fluid.
6. Disconnect the clutch pressure line "8" by releasing the clamp "6" and collect the escaping brake fluid.
7. Remove the clutch actuator and the TCU together by loosening the clutch actuator screws "1", "7" and "10".

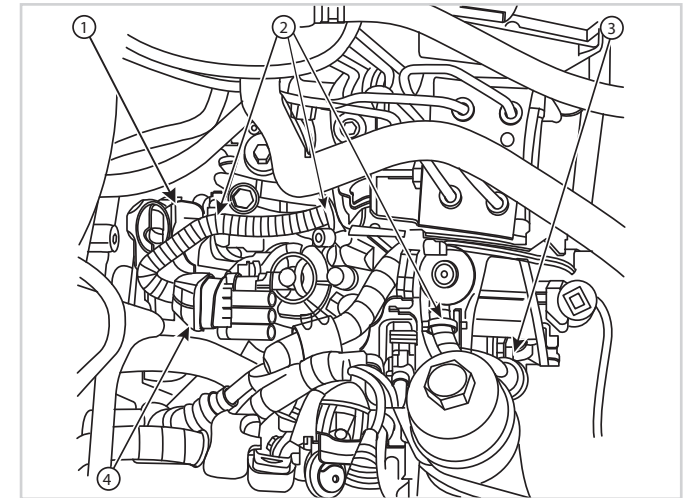

The wiring harness

1. Unlock and remove the wiring harness plug "3" from the Easytronic.
2. Unlock and remove the wiring harness plugs "1" and "4" from the shift module.
3. Loosen the cable tie "2".
4. Remove the wiring harness.

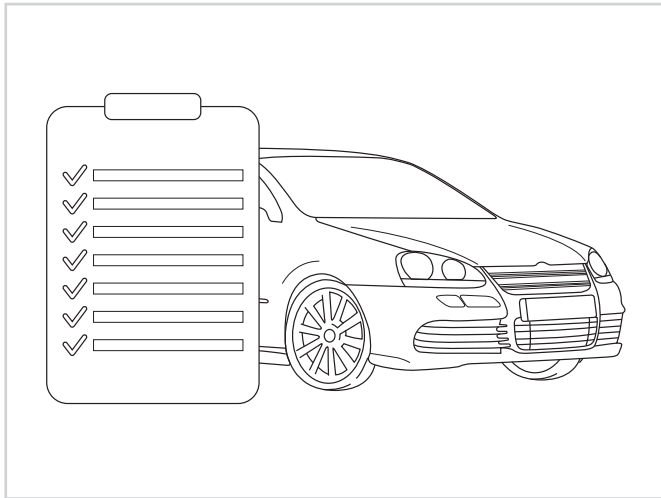

The gear selector (shift motors)

1. Turn the ignition on and keep the brake pedal pressed.
2. Set the selector lever to "N".
3. Release the brake pedal and turn off the ignition.

4. Only for motors Z13DT and Z13DTJ:

Remove the crash box and the pressure filling tube. To do this, remove 4 bolts.

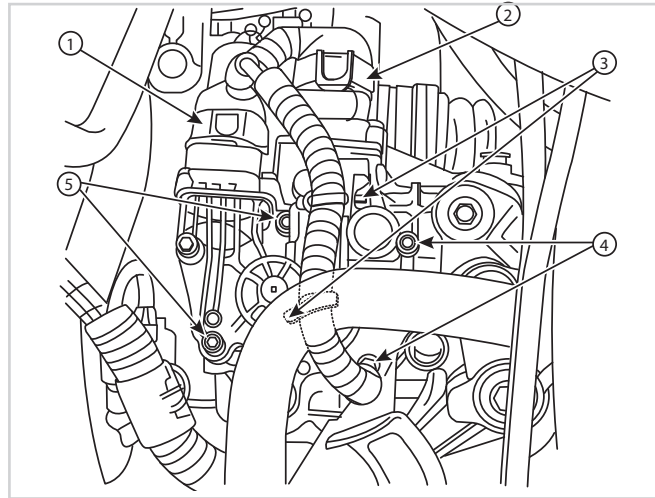

5. Unlock and remove the wiring harness plugs "1" and "2" from the gear selector.
6. Loosen the cable tie "3".
7. Remove the bolts "4" and "5".
8. Lift the gear selector and tilt it forward to remove it.
9. Clean the sealing surface and the threaded holes where the shift module is mounted on the gearbox.

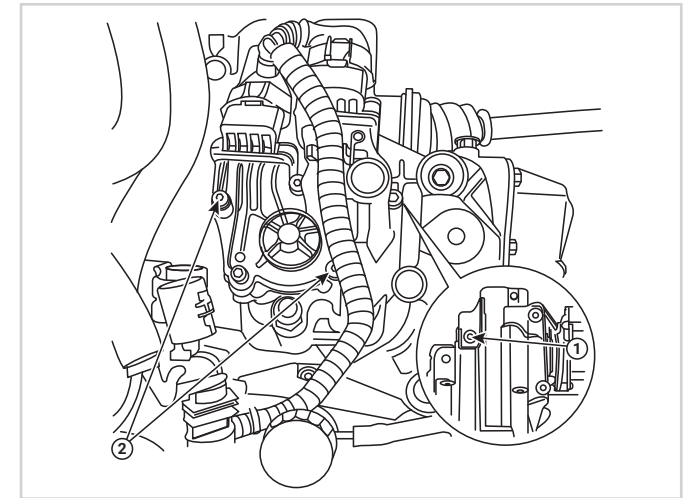

If removal is not possible

If it is not possible to remove the actuator (e.g. due to a defect or external cause) as described below, consider both shift motors as separate components. Proceed as follows:

1. Remove the bolts "1" of the 1st shift motor.
2. Remove the 1st shift motor.
3. Remove the screws "2" of the 2nd shift motor.
4. Remove the 2nd shift motor

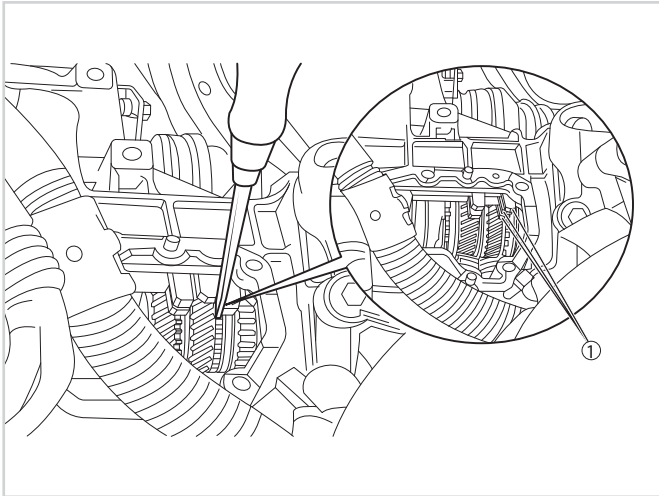
**Only perform in case of a defective gear selector**

Should the gear selector have to be removed because it is defective, then it is necessary to carry out an extra step:

1. Move the gearbox to neutral by allowing the selector forks "1" to coincide: use a screwdriver to move the selector forks.
2. Reverse gear must not be engaged.

OFFER FOR REMANUFACTURE

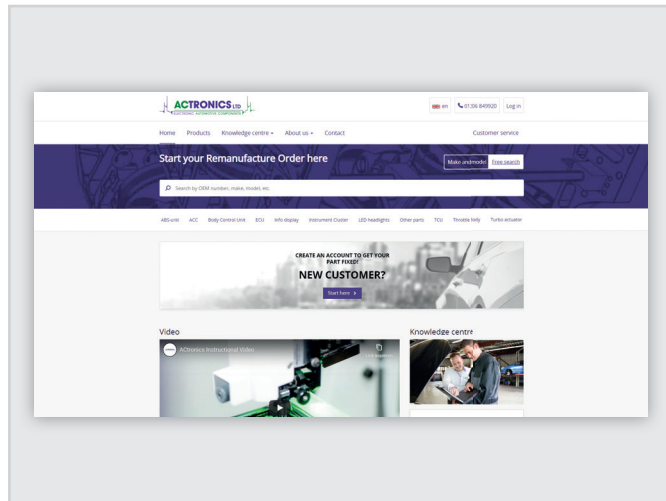

Sign up online

- › Go to www.actronics.co.uk and click on "Free search".
- › Then enter "Easytronic" and the product will immediately appear on the screen.
- › Click on "View product" and follow the dropdown menu.
- › You have now selected the right product.
- › Now click on "Next" and log in to complete the registration.
- › Print the [Remanufacture Order Form](#) after registration.



Shipping

When an Easytronic is offered for revision, the TCU with clutch actuator, the shift motors and the TCU wiring harness must be sent **together**. In this way, the entire system can be tested and a complete system remanufacture can be carried out.

Because the clutch pump is very vulnerable, it is better not to send it along so as to prevent transport damage. Therefore, before sending the TCU to us, disassemble the clutch pump. For further instructions on how to remove the clutch pump, look on page 103.



IMPORTANT:

Enclose the printed Remanufacture Order Form with the product in the transport packaging. This is crucial for identification upon receipt.

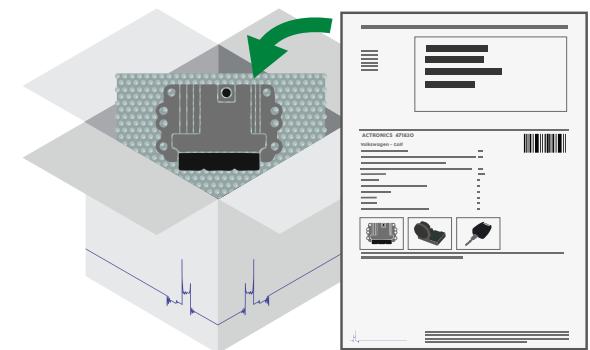

INSTALLING THE EASYTRONIC COMPONENTS AFTER REMANUFACTURING

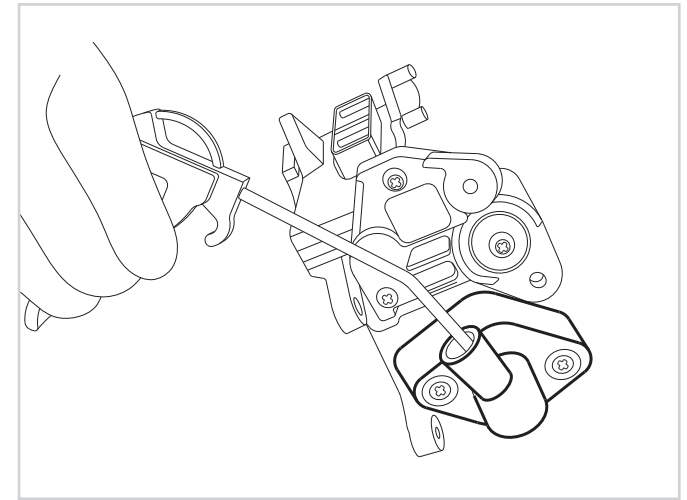
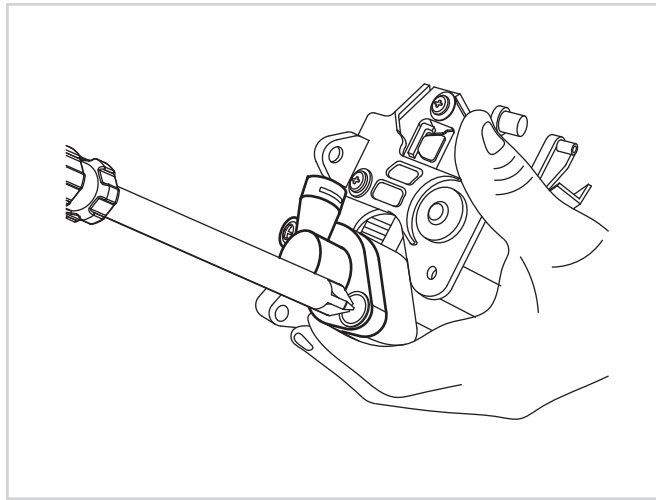
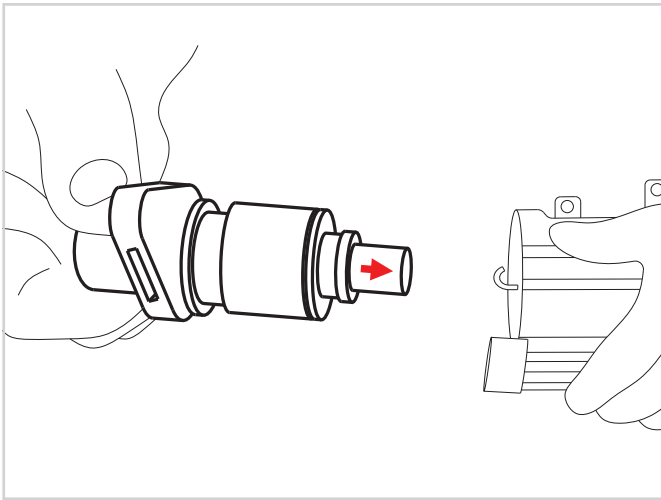
**The clutch pump**

If (to prevent transport damage) the clutch pump has been disassembled, it must first be reassembled:

1. Pull the piston rod all the way out, as shown by the red arrow in the illustration.
2. Place the clutch pump on the TCU.
3. Screw the clutch pump hand-tight.
4. The piston rod must be clamped back onto the drive rod. By applying air pressure to the pump outlet, the piston pushes the piston rod back onto the drive rod. You will hear a click when the clutch locks securely.

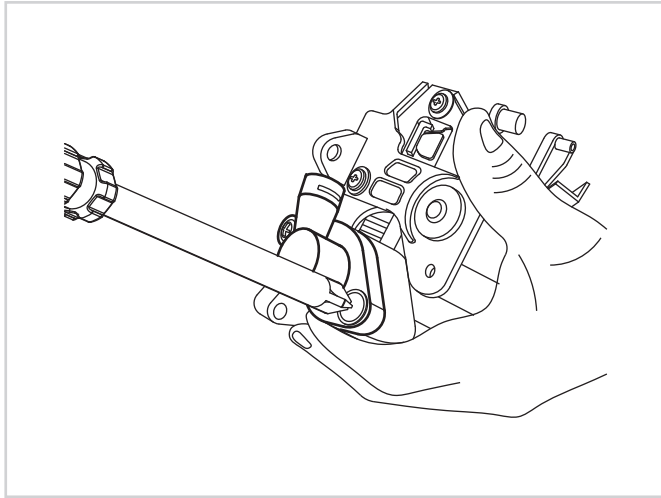

5. Remove the clutch pump screws.

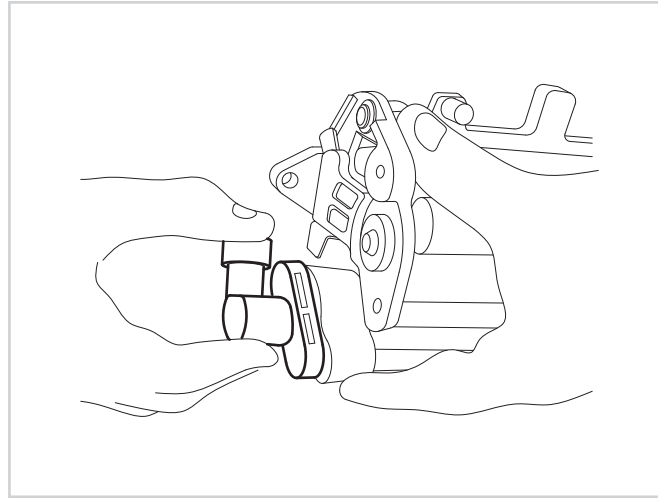

6. Now carefully pull out the clutch pump as indicated by the red arrow.

If the piston rod is **mounted correctly**, the pump can now only be pulled out of the TCU a small distance: resistance can be felt.

The piston rod is **not properly mounted** if the pump is easily pulled out of the TCU.

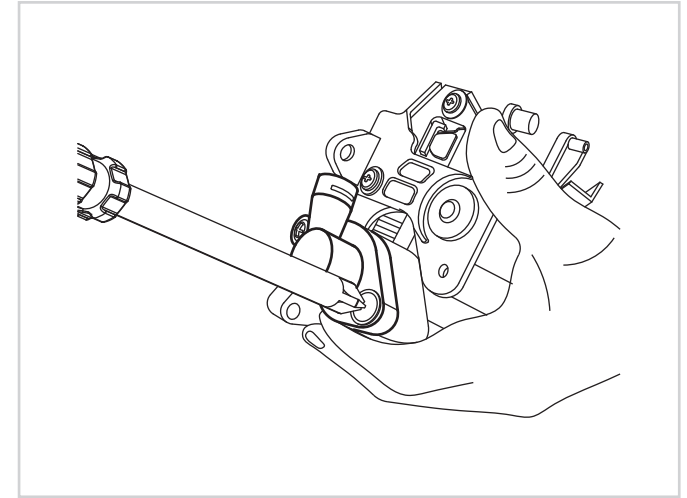

7. Has it been established that the piston rod is correctly mounted? Then finally screw the clutch pump in place.

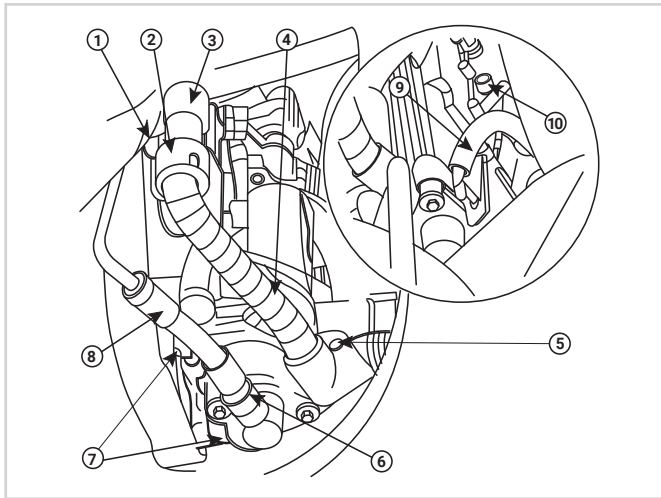

The Easytronic

1. Fasten the Easytronic with bolts "1", "7" and "10". Tightening torque: 11 Nm.
2. Push the brake fluid supply hose "8" onto the connection of the clutch actuator as far as it will go.
3. Press the clutch pressure line "6" firmly onto the clutch actuator connector until you hear and feel a click.
4. Connect the wiring harness plug "2" to the Easytronic and lock the plug.
5. Re-attach the wiring harness holders "4" and "5".
6. Mount the lower engine panelling (if applicable).
7. Connect the wiring harness plug "3" to the Easytronic and lock the plug.

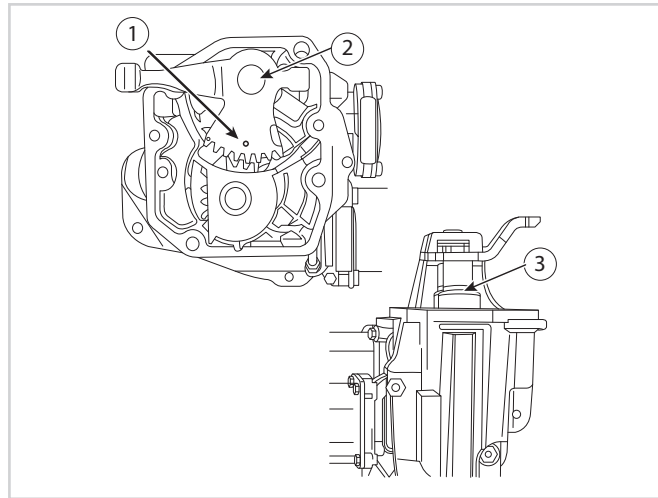

The gear selector

1. Align the marking "1" of the shift shaft "2" with the pinion of the shift motor.
2. Set the shift axle to the neutral position. Groove "3" is then visible and in line with the collar of the bushing.

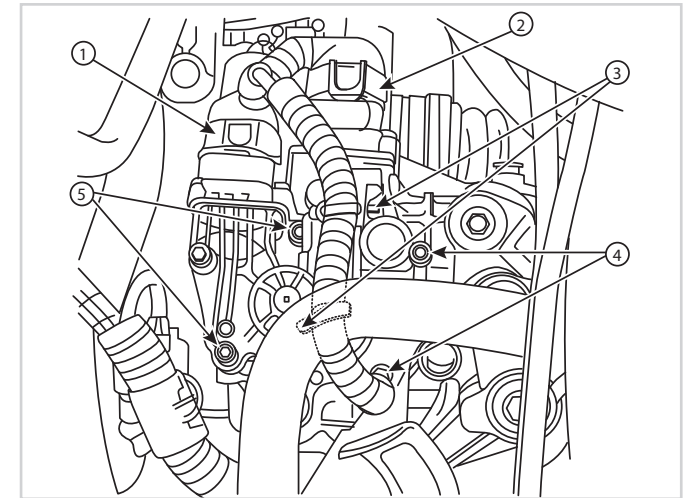

3. Fit the gear selector with a **new** gasket and fit four **new** bolts in places "4" and "5". Tightening torque: 11 Nm.
4. Re-attach the wiring harness plugs "1" and "2" to the gear selector. (The fit of both plugs is different, so it is not possible to confuse them)
5. Secure the wiring harness with 2 cable ties in place "3".

6. Only for motors Z13DT and Z13DTJ:

Reinstall the crash box and the pressure filling tube. To do this, install 4 bolts.

The wiring harness

Please refer to the instructions for further details.

PROCEDURES AFTER INSTALLATION

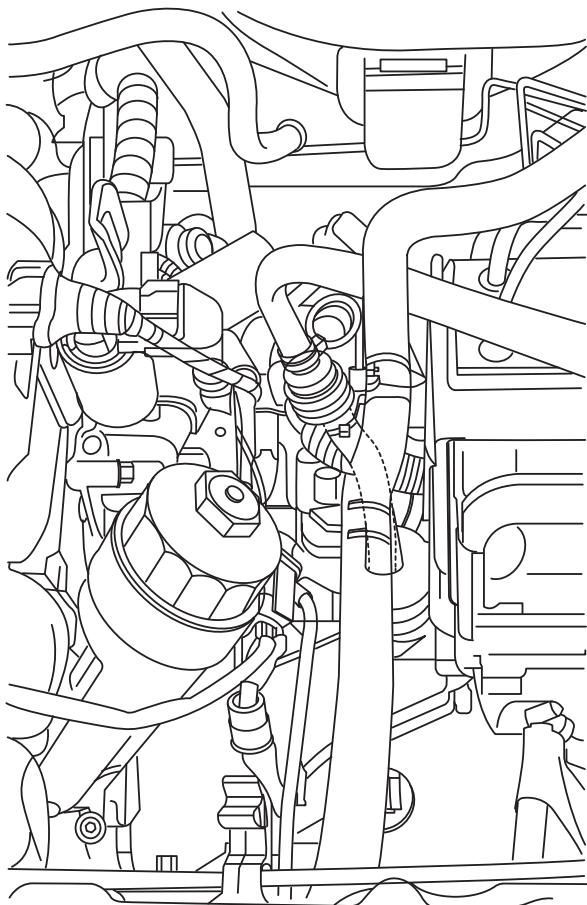

Bleeding the clutch

Bleeding is not only necessary after installation but also for locating leaks.

In Opcom, the bleed program is located under the (Programming) menu. It describes each step of the bleed process.

The simplest way of bleeding is to use a retention vessel (liquid vessel with a pressure of 2 bar). Always use at least Dot 4 brake fluid.

1. Only for motors Z13DT and Z13DTJ:

Remove the crash box and the pressure filling tube. To do this, remove 4 bolts.

2. Remove the valve cap from the bleed valve.
3. Connect a hose with a suitable brake fluid collection reservoir to the bleed valve.
4. Remove the cover from the hydraulic fluid reservoir.
5. Screw the brake bleed adapter onto the hydraulic fluid reservoir.
6. Connect the TECH 2 diagnostic device and select (Auto Diagnostics) from the main menu.
7. Select the corresponding auto-identification.
8. Select (Transmission) from the (System selection) menu.
9. Select auto-identification (Easytronic (MTA)).
10. Select (Additional functions) in the (Transmission) menu.
11. Select (Bleeding the clutch hydraulics) in the (Additional functions) menu.
12. Retrieve the programming permission from TIS 2000.
13. Reconnect the TECH 2.
14. Select (Bleeding the clutch hydraulics) again in the (Additional functions) menu.
15. Follow the further menu structure of TECH 2 until the end of the program.

16. Only for motors Z13DT and Z13DTJ:

Reinstall the crash box and the pressure filling tube. To do this, install 4 bolts.

17. Attach the valve cap to the manifold bleed valve.

18. Screw the cover onto the hydraulic fluid reservoir.
19. Clear the error code memory, take a test drive, and read out the error code memory.

Determining the clutch touch point

1. Connect the TECH 2 diagnostic device.
2. Select the corresponding auto-identification.
3. Select (Transmission) from the (System Selection) menu.
4. Select auto-identification (Easytronic (MTA)).
5. Select (Additional Functions) in the (Transmission) menu.
6. Select (Touch Point Determination) in the (Additional Functions) menu.
7. Retrieve the programming permission from TIS 2000.
8. Select (Touch Point Determination) again in the (Additional Functions) menu.
9. Follow the further menu structure of TECH 2.

Learning the transmission parameters

After reinstalling the Easytronic system, it is important that the transmission parameters be taught correctly:

1. Connect the TECH 2 diagnostic device.
2. Select the corresponding auto-identification.
3. Select (Transmission) from the (System Selection) menu.
4. Select auto-identification (Easytronic (MTA)).
5. Select (Additional Functions) in the (Transmission) menu.
6. Select (Learn Transmission Parameters) in the (Additional Functions) menu.
7. Retrieve the programming permission from TIS 2000.
8. Select (Learning Transmission Parameters) again in the (Additional Functions) menu.
9. Follow the further menu structure of TECH.



FORD DURASHIFT EST

Manual gearboxes are frequently robotised. Which is actually quite a nice solution because you can basically build any car with the same manual gearbox. The only thing that needs to be added to turn it into an automatic is a piece of mechatronics that controls the clutch and gears, such as, for example, the Ford Durashift. Problem solved!



FORD FIESTA V 2001-2008

Ford Durashift - EST



FORD FUSION 2002-2012

Ford Durashift - EST



MAZDA 2 2003-2007

Ford Durashift - EST



MAZDA 2 2007-2014

Ford Durashift - EST

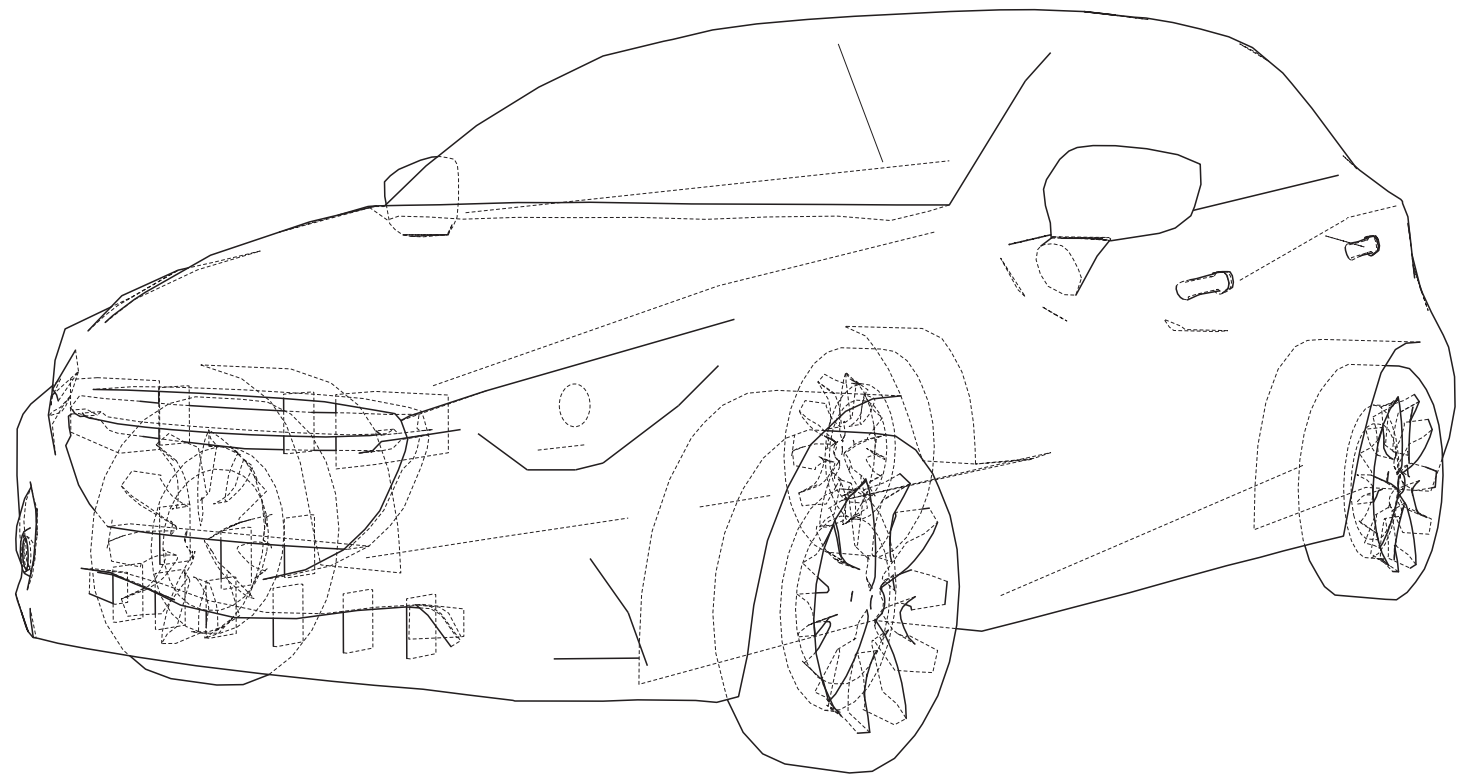

 **KNOWN COMPLAINTS**

- › The gear indicator in the display shows "--" or "N"
- › The "powertrain" warning light is illuminated
- › The car goes into limp mode
- › The gearbox no longer shifts
- › The gearbox shifts randomly to "N" or an illogical gear
- › The car won't start

 **CAN BE REMANUFACTURED**

OBD II	Description
P0810	Clutch position control error
P0919	Gearshift position control error
-	The "powertrain" warning light is illuminated
-	The gear indicator in the display shows "--"

REMANUFACTURE MAY BE POSSIBLE ADDITIONAL DIAGNOSIS REQUIRED

OBD II	Description
P0614	ECM / TCM Incompatible

Remanufacture is only possible on petrol models. In this case, please also send the ECU!

OBD II	Description
P0919-20-TCM	CAN fault with gear selector

For these and other gear selector errors, the problem may be either on the TCU or on the selector lever. In this case, please contact our Customer Service

In many cases, you will be asked to send both the TCU and the selector lever.

OBD II	Description
P0915	Shift position circuit range/performance
P0916	Shift position circuit low
P0917	Shift position circuit high
P2793	Gear shift direction circuit range/performance
P2794	Gear shift direction circuit low
P2795	Gear shift direction circuit high

These error codes often appear when there is a problem in the Durashift system wiring. Check in particular the wiring harness between the shift motors and the Mechatronic.

Is the wiring really OK? If so, then the shift motor may really be defective. In this case, the Mechatronic must still be remanufactured.

If in doubt, please contact our Customer Service.

Telephone: 01206 849920

CANNOT BE REMANUFACTURED

OBD II	Description
P1750	Maximum adapted (EPC) pressure for reverse

This complaint usually has a mechanical cause. Check the gearbox carefully for damage/wear. Furthermore, dirty hydraulic fluid can be the cause. More information about this can be found in the chapter "General operation" at page 115.



PIN ASSIGNMENT FOR CONNECTOR 1 OF THE TCU (C-676)

Pin 45	K-line
Pin 47	Power supply 12V +15
Pin 48	Ground 31
Pin 49	Power supply 12V +30
Pin 52	Brake light switch
Pin 54	CAN high
Pin 56	CAN low
Pin 57	Complement from pin 74 (interspersed with ecu check pulses)
Pin 59	Front door alarm switch
Pin 61	Link CAN high
Pin 63	Link CAN low
Pin 74	Manual position = pulse train to 12V Auto position = pulse train to 10V
Pin 76	Data burst signal
Pin 77	Clock burst signal
Pin 78	Start signal

The pin numbers in **bold** refer to the selector lever, which can be used to change gears manually if necessary. See also the wiring diagram for both types (2-wire or 4-wire).

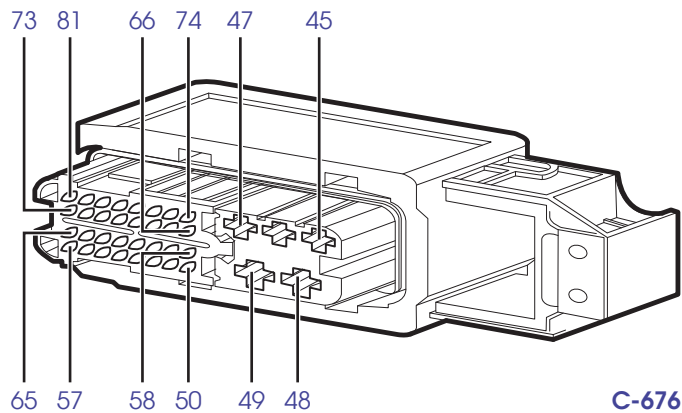

PIN ASSIGNMENT FOR CONNECTOR 2 OF THE TCU (C-712)

Pin 106	Sensor input 2 (counter)
Pin 107	Sensor input 1 (direction)
Pin 108	Sensor input 2 (counter)
Pin 109	Sensor input 1 (direction)
Pin 114	Engine ground
Pin 115	Engine ground
Pin 116	Power supply 12V motor
Pin 117	Power supply 12V motor
Pin 118	Power supply 12V sensor
Pin 119	Power supply 12V sensor
Pin 120	Ground sensor
Pin 121	Ground sensor

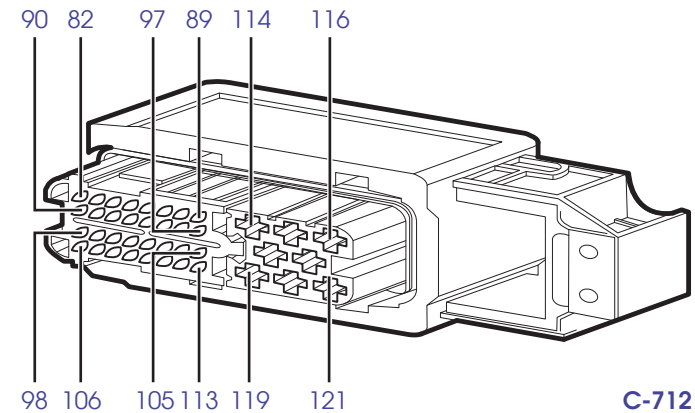

PIN ASSIGNMENT FOR THE CONNECTORS OF THE SHIFT MOTORS (C-677 AND C-678):

Pin 1	Power supply 12V motor
Pin 2	Ground sensor
Pin 3	Power supply 12V sensor
Pin 4	Sensor output 1 (direction)
Pin 5	Sensor output 2 (counter)
Pin 6	Engine ground

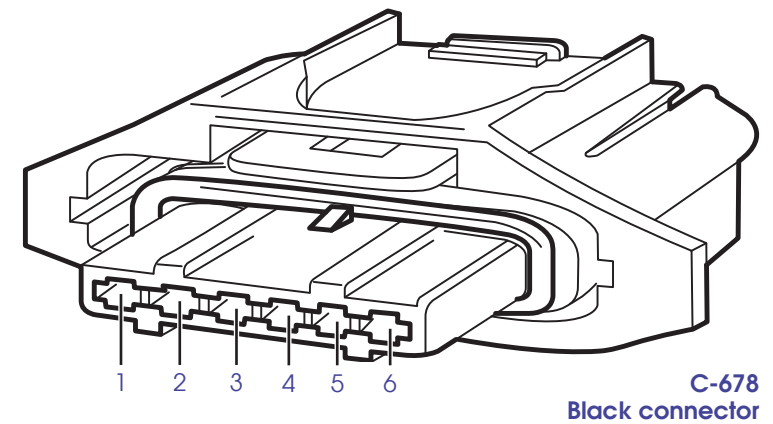
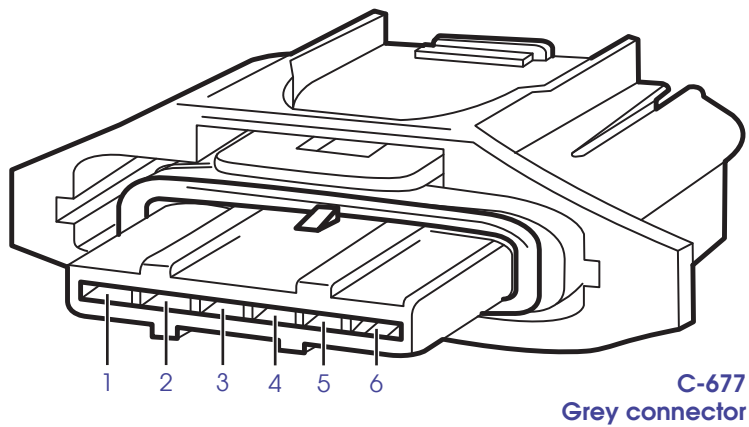

ELECTRIC SCHEMATIC

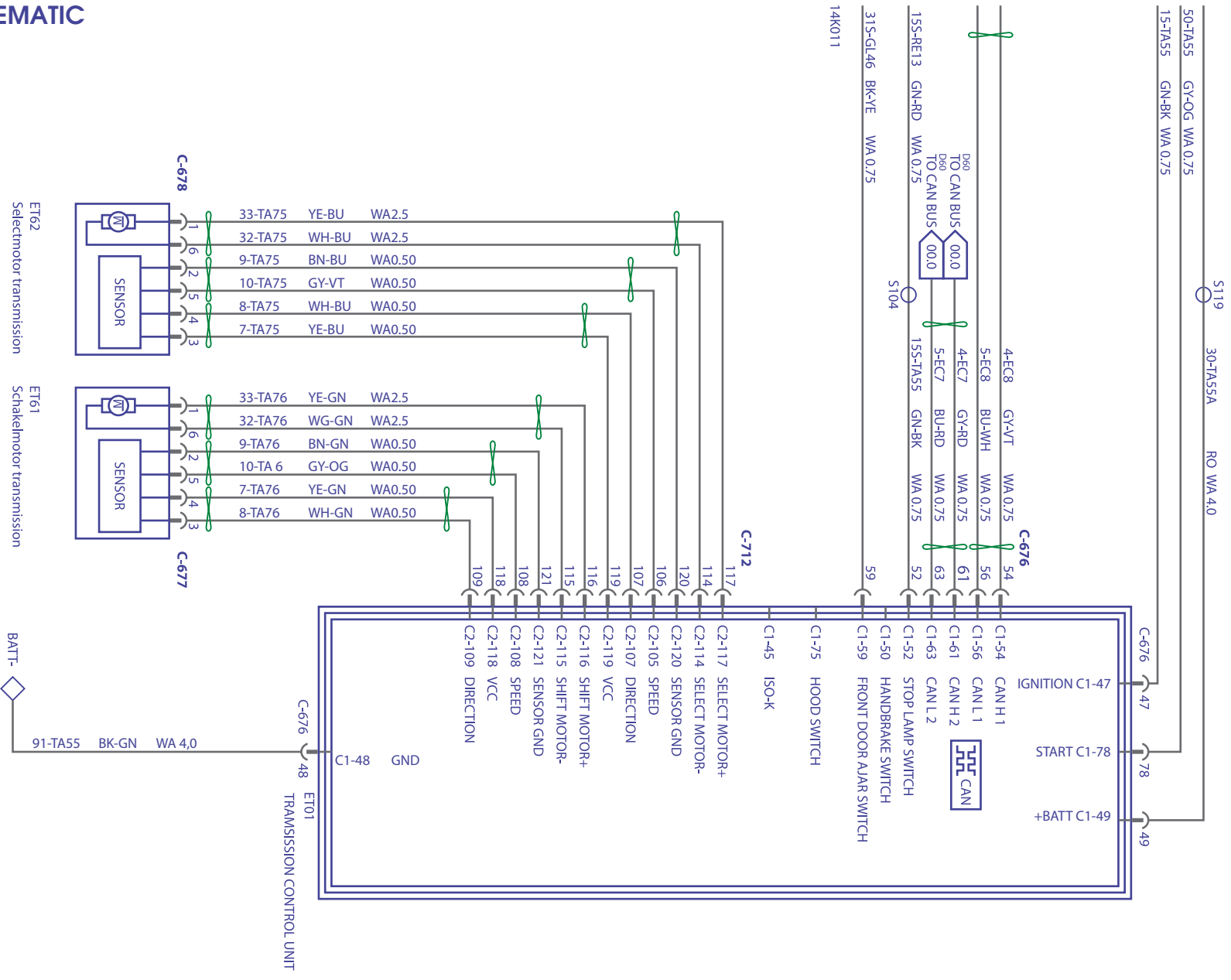

GENERAL OPERATION



The Durashift system is a so-called robotised manual gearbox based on Ford's iB5 five-speed manual gearbox. The Durashift gearbox allows both automatic shifting and shifting with the selector lever. In both cases, the clutch is operated automatically.

For hydraulic disconnection, an electric motor drives a hydraulic pump in the clutch actuator. The gearbox shifts via the two electric motors in the gearbox

actuator: the selection motor and the shift motor. The selection motor selects the shift area and the shift motor engages the gearbox.

The system is controlled from the TCU (Transmission Control Unit) which is mounted on the clutch actuator and is connected to the switching actuator and to the car wiring via the wiring harness. The selector lever allows the driver to select whether he wants to shift automatically or manually. It can also be used to select reverse gear and neutral. In the case of manual shifting, the selector lever is used to shift up and down.

Possible causes of gearbox problems

A Durashift gearbox that does not work does not automatically mean that electrical components are faulty. We can therefore identify three specific components that are more likely to fail:

1. Clutch system

A clutch is always subject to wear and tear, so it is wise to check the clutch and the pressure group before focusing on the rest of the gearbox. Because the clutch is operated automatically, the driver does not notice that the clutch is starting to wear out or not working as well. To the layman, the mechanism seems to be "suddenly" faulty.

2. Hydraulic fluid

There are many cases where the system has not been maintained for years and where extensive flushing and bleeding has completely solved all problems. The flushing and bleeding of the hydraulic circuit has even more advantages: possible malfunctions

of the clutch actuator can be detected relatively easily (see also "The Mechatronic in detail"). This is because the bleeding procedure is so extensive that deviations can easily be spotted when operating the clutch actuator. It is not uncommon for this actuator to stop working properly.



3. Crankshaft sensor

Check carefully that the crankshaft sensor is doing its job all the time. Failing crankshaft sensors are commonplace. In this case, too, the common "N" appears on the display. You disassemble the entire gearbox and send the Mechatronic for repair, only to find out right at the end that a simple sensor is defective...

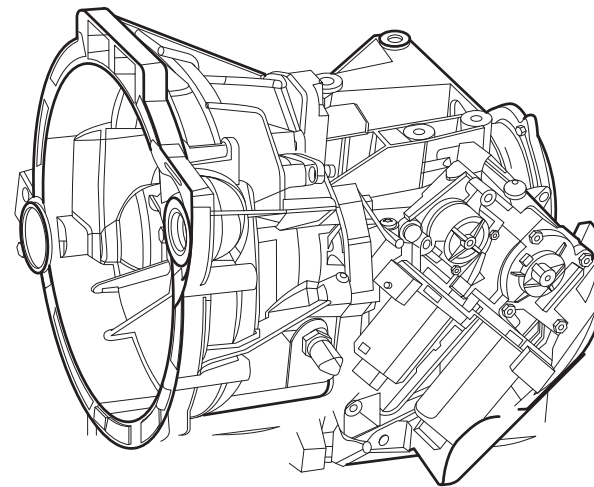

Complaints because of contaminated hydraulic fluid

Unfortunately, the periodic change of the hydraulic fluid is often neglected. What many people don't seem to think about is the fact that old/dirty hydraulic fluid can cause a lot of problems. Moving parts can cause excessive wear and therefore even leaks. It is also possible that certain channels may become clogged.

Sometimes these complaints can be solved by flushing and venting the system with a suitable diagnostic device. However, excessive wear may already have occurred.

THE MECHATRONIC IN DETAIL

The Mechatronic consists of three different parts: the Durashift (the actual mechatronic part), the gear selector and the gear selector lever. Unfortunately, the name "Durashift" is alternately used in various documentation for the system as a whole or just to indicate the mechatronic part. So pay close attention to what is meant!

Durashift

Durashift is the name of the mechatronics that control the clutch and the gear selector. The component consists of a TCU, a clutch actuator and an electric motor.



The most vulnerable part of the Durashift is the clutch actuator. It is mounted in a plastic housing and can quickly start leaking. If you suspect that the clutch actuator is leaking, carry out the official bleeding procedure at all times (see at page 124). The clutch actuator will certainly leak if it is defective.

The gear selector

The gear selector consists of two electric shift motors. These shift motors are used to select the gears. As explained above, both motors are controlled by the TCU, which is located in the Durashift.



The gear selector is still controlled in the "old-fashioned" way by the TCU. This means that CAN messages are not used, but power, ground and signals for direction and time are used. Because both signals are necessary to activate these "smart" electric motors, it is unfortunately not possible to connect power and ground to test the electric motors yourself.

The gear selector lever

The gear selector lever occasionally causes strange malfunctions. The mechanism is not entirely mechanical, as in a normal manual gearbox: the selector lever operates the gears by sending an electrical signal (so no CAN message!) to the TCU in the



Want to check if the signal is still being sent?

On page 112 you can see which pins in the TCU connector are intended for the gear selector lever. For example, the signal at pin 76 should change when the selector lever is moved from "N" to "R".

And a pulse train to 12V must be visible on pin 74 in manual mode. In automatic mode, the pulse train must drop to 10V.

Durashift. It is therefore more like a joystick. The signal sent depends on the position in which the selector lever is set. It often fails as soon as the contact points become worn out: the correct signal is no longer sent to the TCU.

Differences compared to Bosch Easytronic

The fact that Ford has chosen to use the name "Durashift" does not mean, of course, that the Easytronic system from Bosch suddenly works completely different. In fact, the components have all been taken over unchanged! For those who are already familiar with Easytronic, Durashift is a feast of familiarity.

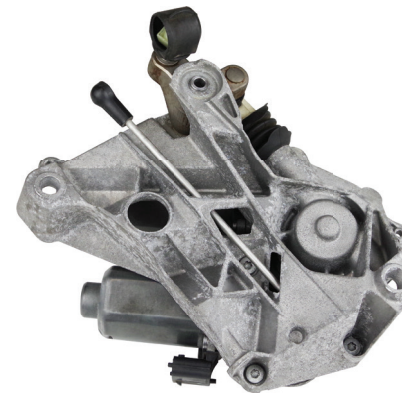

Real differences should be sought more in the assembly of the components. Ford has applied the Mechatronic to a gearbox of its own and therefore the mounting position differs from that of Vauxhall. The wiring has also been modified slightly: whereas Vauxhall always uses a standard wiring harness, Ford has some variations.

REMOVING THE DURASHIFT COMPONENTS

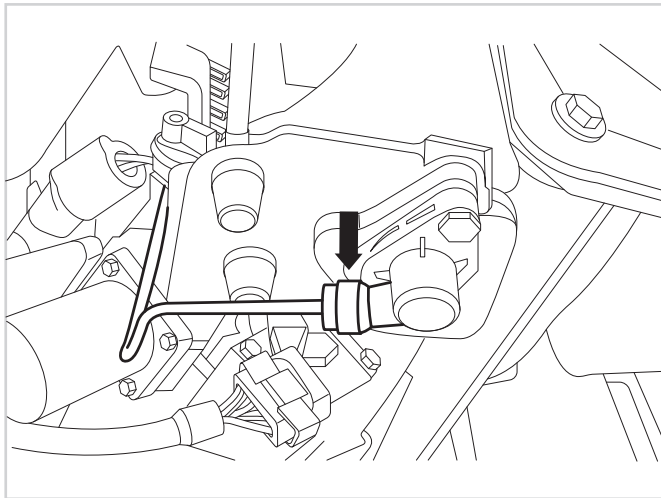

The Durashift

The Durashift is mounted in the engine compartment on the side member at front left.

1. Remove the cover of the hydraulic fluid reservoir.
2. Release and remove the wiring harness plug from the Durashift.
3. Place a container to catch the brake fluid.
4. Remove the spring clip from the brake fluid supply hose and pull out the brake fluid supply hose. Collect the escaping brake fluid.

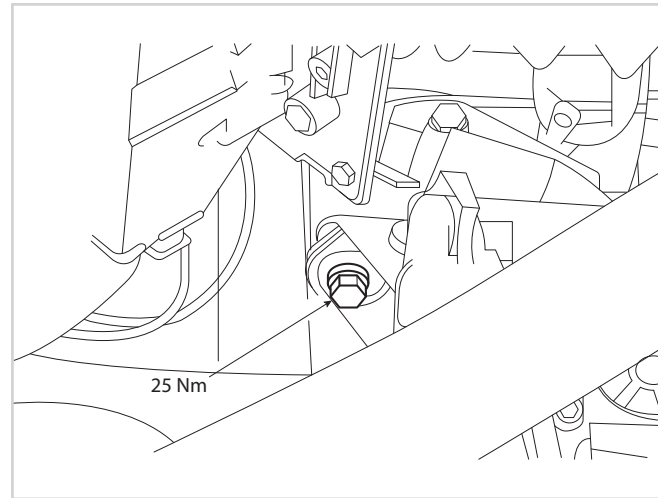

5. Remove the torque limiter and the TCU together by loosening the torque limiter bolt.

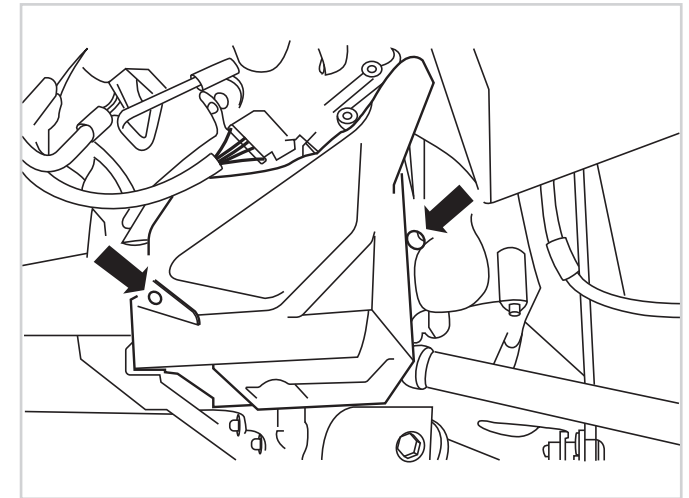

The gear selector

The gear selector is best disassembled from below. The use of a lift is therefore recommended.

1. Remove the cover of the shift actuator.

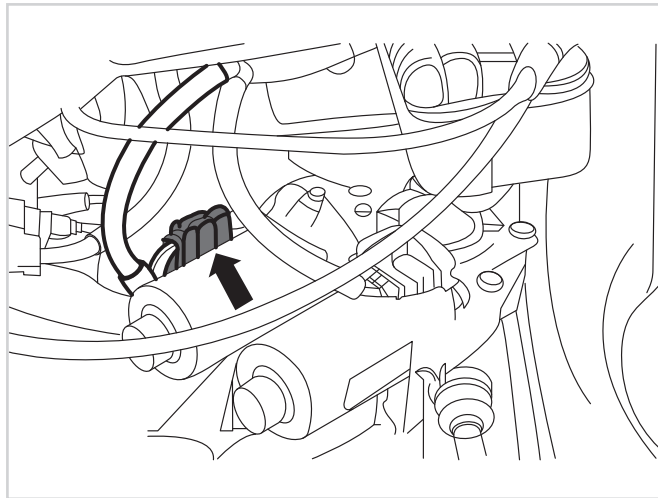
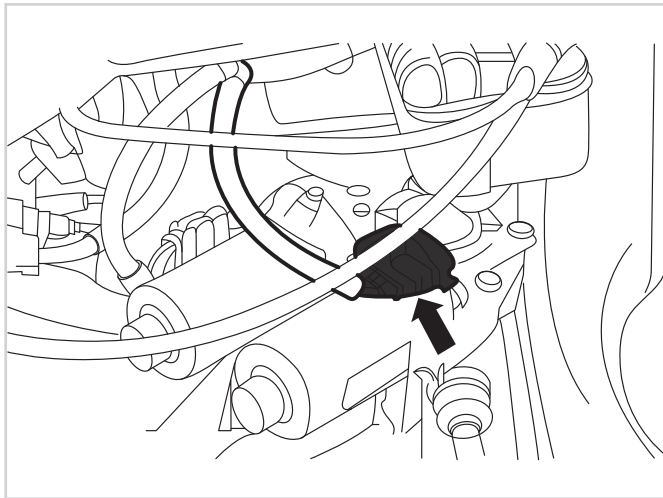

2. Disconnect both plugs from the shift actuator: the black plug is on top of a shift motor, the grey plug is blocked on the side of a shift motor. See illustrations above.

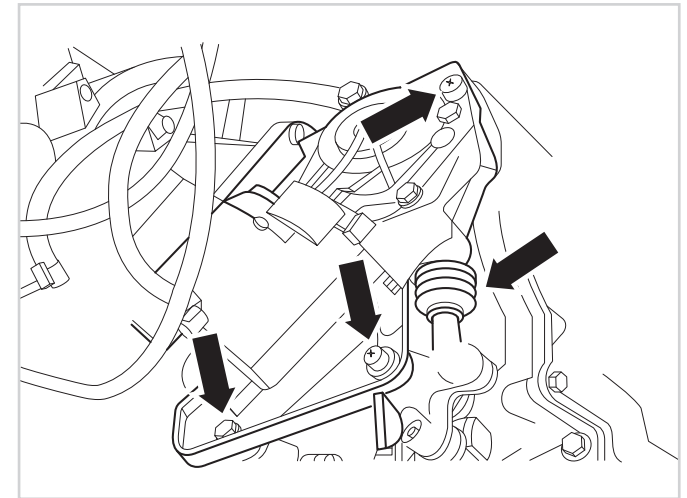

3. Click the black "bowl" of the control rod out of the "sphere" of the ball coupling.
4. Loosen the three fixing bolts and remove the shift actuator with base plate from the gearbox.

OFFER FOR REMANUFACTURE

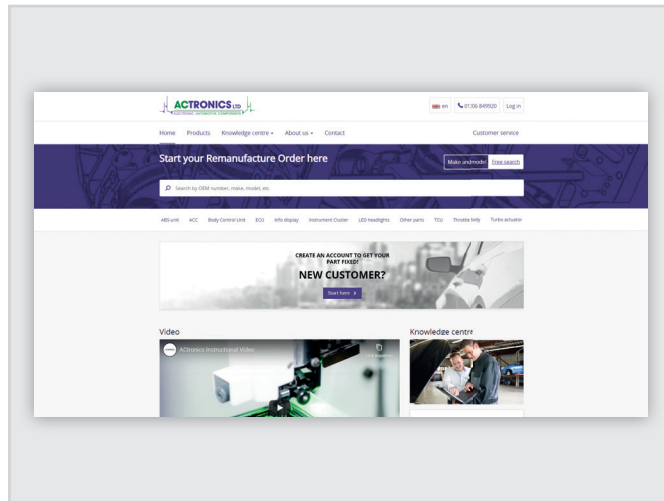

Sign up online

- › Go to www.actronics.co.uk and click on “Free search”.
- › Then enter “Durashift” and the product will immediately appear on the screen.
- › Click on “View product” and follow the dropdown menu.
- › You have now selected the right product.
- › Now click on “Next” and log in to complete the registration.
- › Print the [Remanufacture Order Form](#) after registration.



Shipping

When a Durashift is presented for remanufacture, the TCU with clutch actuator, the shift motors and the TCU wiring harness must be sent **together**. In this way, the entire system can be tested and a complete system remanufacture can be carried out.

Because the clutch pump is very vulnerable, it is better not to send it along so as to prevent transport damage. Therefore, before sending the TCU to us, disassemble the clutch pump. For further instructions on how to remove the clutch pump, look on page 120.



IMPORTANT:

Enclose the printed Remanufacture Order Form with the product in the transport packaging. This is crucial for identification upon receipt.

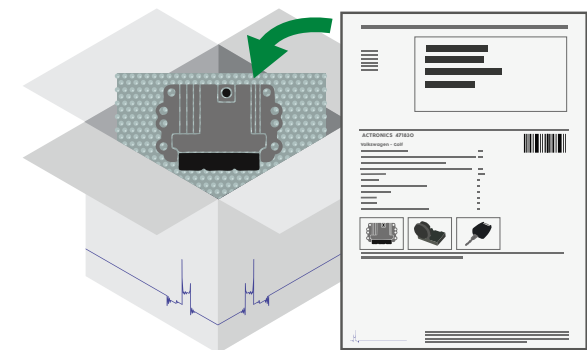

INSTALLING THE DURASHIFT COMPONENTS AFTER REMANUFACTURING

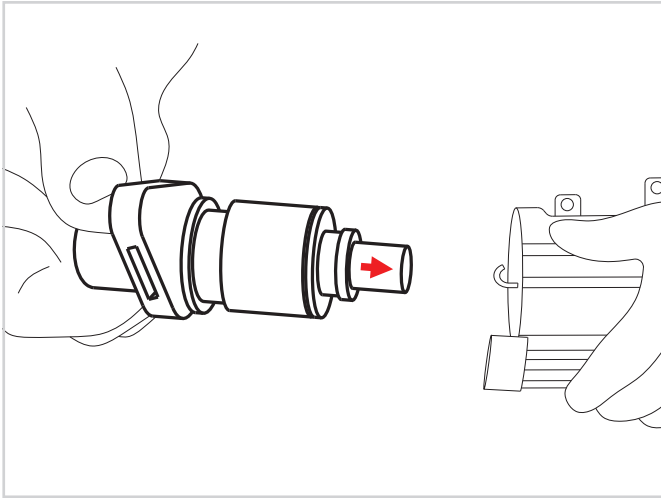
**The clutch pump**

If (to prevent transport damage) the clutch pump has been disassembled, it must first be reassembled:

1. Pull the piston rod all the way out, as shown by the red arrow in the illustration.
2. Place the clutch pump on the TCU.

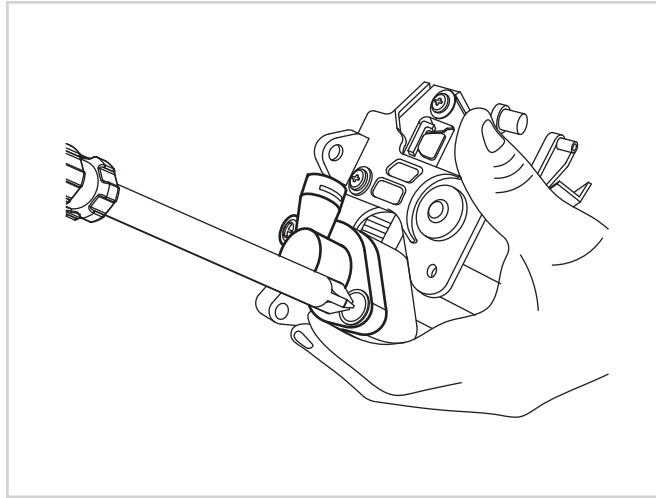

3. Screw the clutch pump hand-tight.

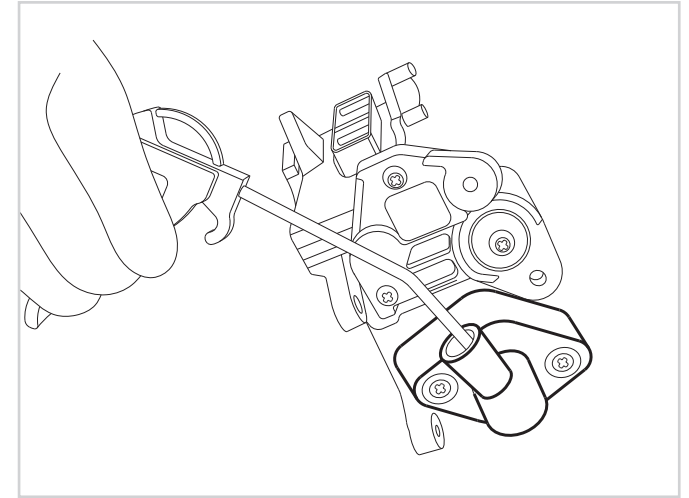

4. The piston rod must be clamped back onto the drive rod. By applying air pressure to the pump outlet, the piston pushes the piston rod back onto the drive rod. You will hear a click when the clutch locks securely.

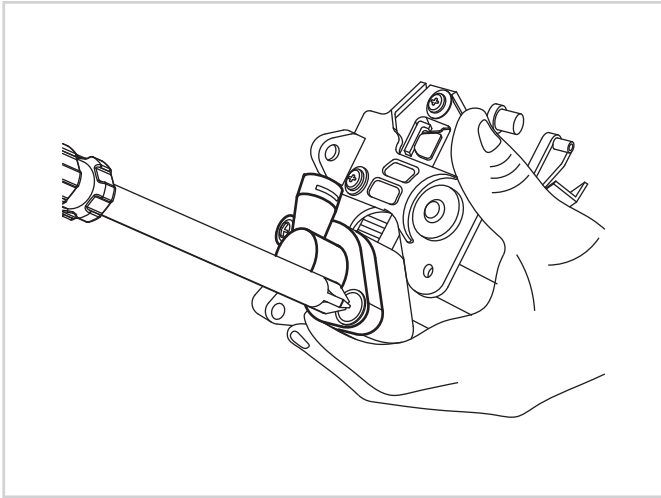

5. Remove the clutch pump screws.

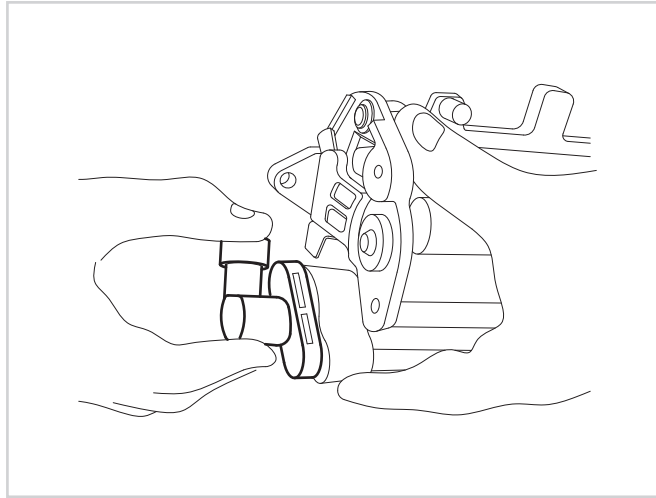

6. Now carefully pull out the clutch pump as indicated by the red arrow.

If the piston rod is **mounted correctly**, the pump can now only be pulled out of the TCU a small distance: resistance can be felt.

The piston rod is **not properly mounted** when the pump is easily pulled out of the TCU.

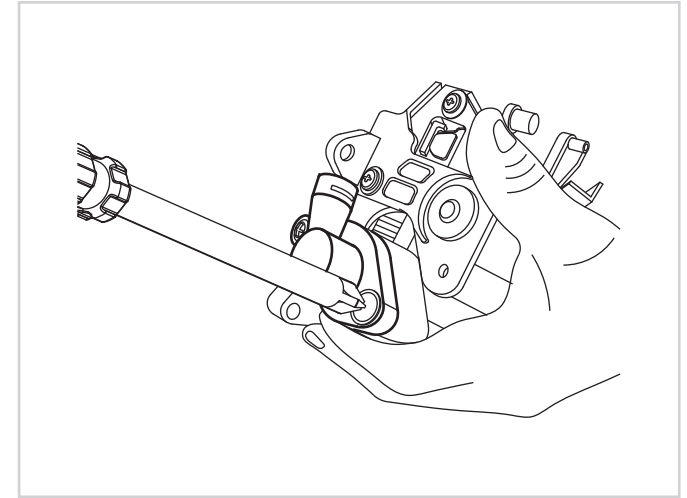

7. Has it been established that the piston rod is correctly mounted? Then finally screw the clutch pump in place.

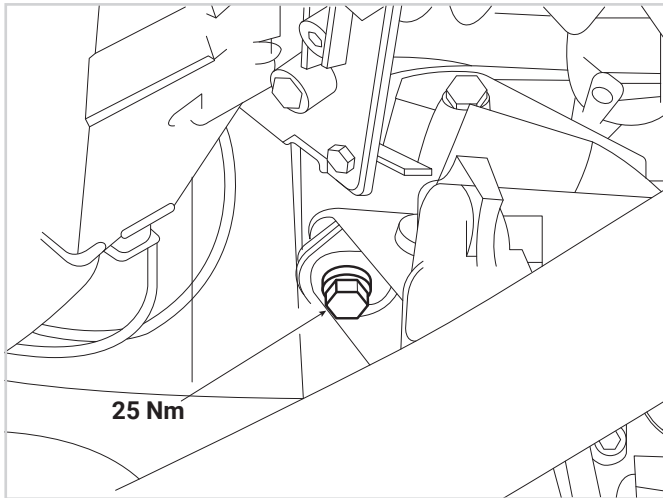

The Durashift

1. Assemble the torque limiter and the TCU together by tightening the torque limiter bolt. Tightening torque: 25 Nm.

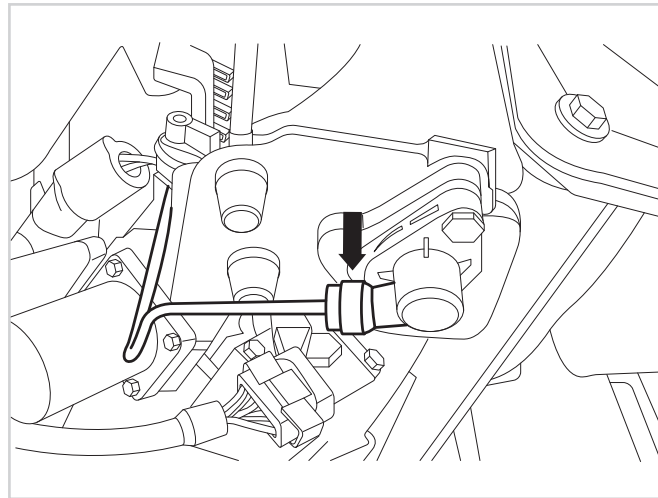

2. Replace the brake fluid supply hose on the connection and mount the spring clip.
3. Install the wiring harness plug of the Durashift.

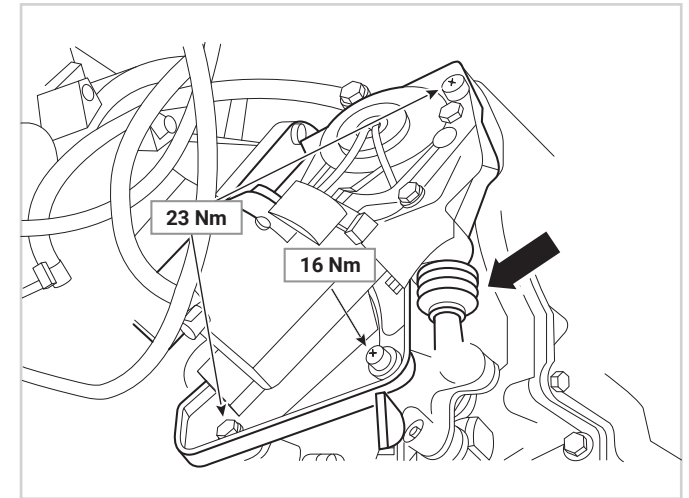

The gear selector (shift motors)

1. Mount the gear selector by tightening the 3 bolts. See illustration for correct tightening torques.
2. Click the black "bowl" of the control rod back on the "sphere" of the ball coupling.

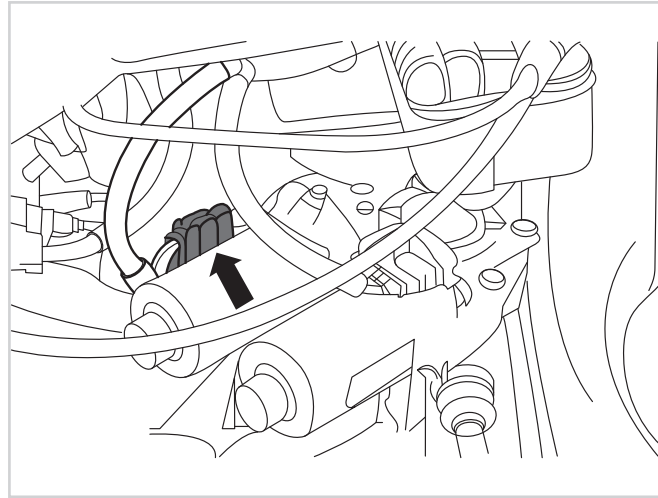
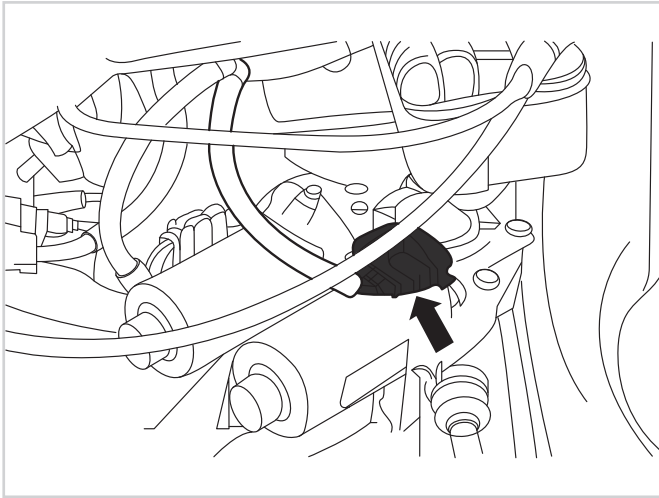

3. Attach both plugs to the shift actuator: the black plug belongs on top of a shift motor, the grey plug belongs on the side of a shift motor. See illustrations above.

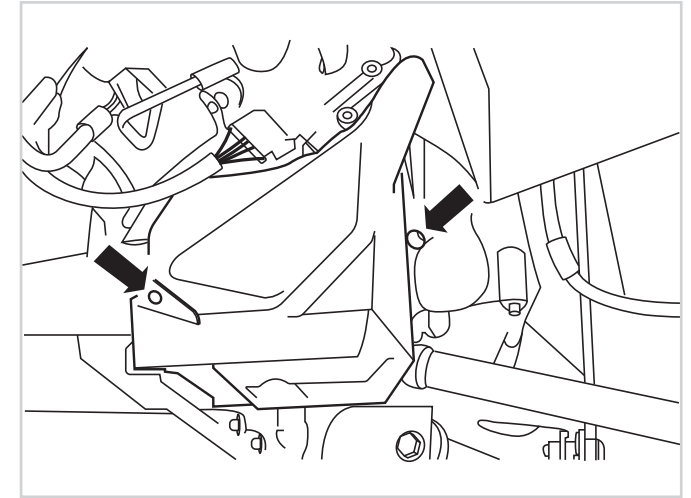

4. Install the cover of the shift actuator.

PROCEDURES AFTER INSTALLATION

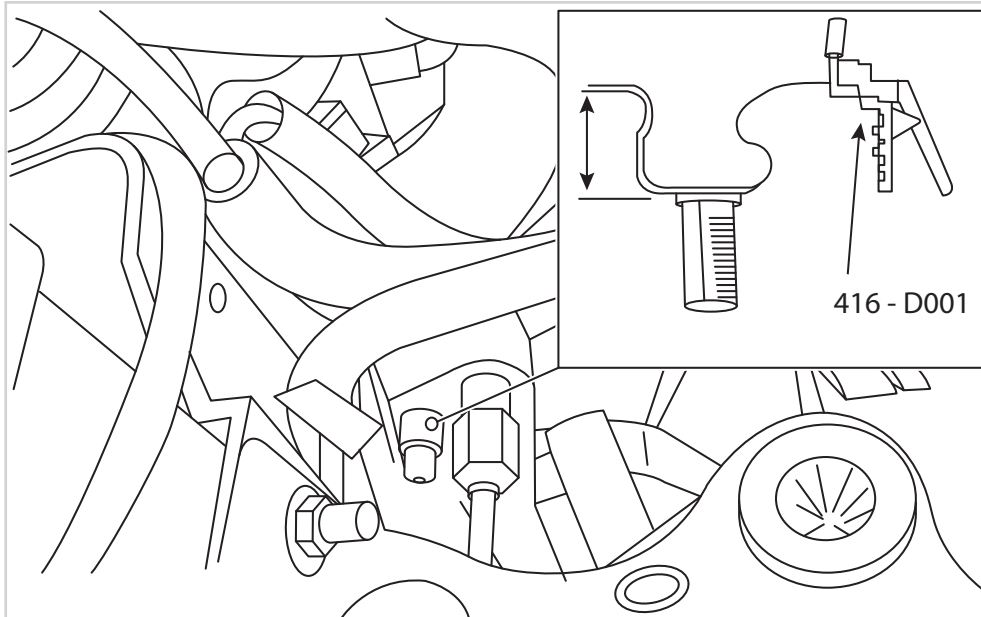

Preparation

1. Check the level in the brake fluid reservoir.
2. If necessary, top up with DOT4 brake fluid to the "MAX" mark on the reservoir.
3. Connect the suction line of the manually operated fluid pump to the plastic bleed nipple.



The bleed nipple can be opened and closed by hand or with a spanner. Make sure that the reservoir of the manual fluid pump is below the level of the bleed nipple during bleeding (see illustration).

4. Continuously monitor the brake fluid level throughout the procedures and top up if necessary.

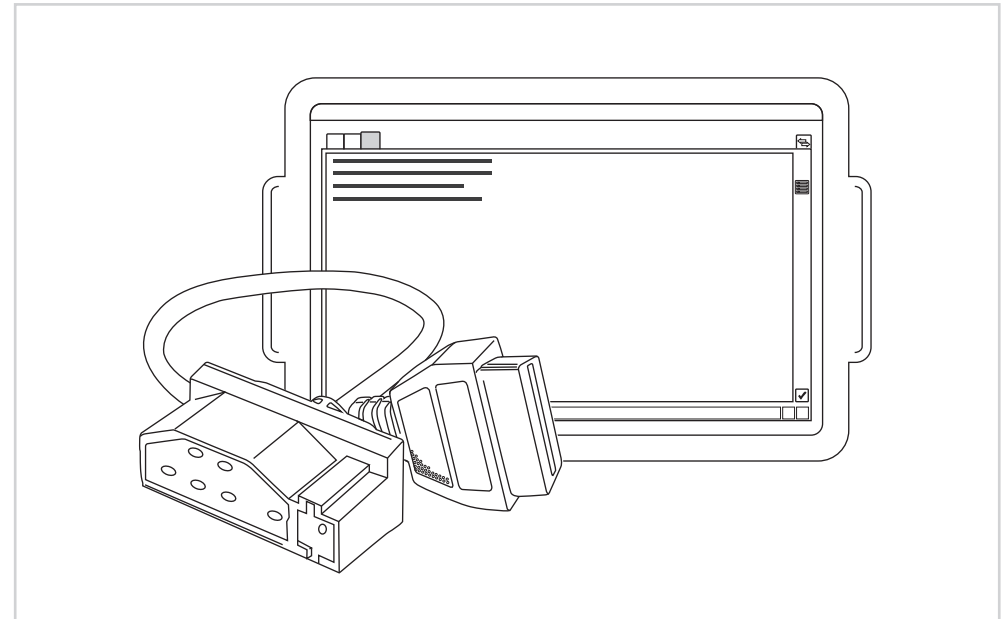

Performing procedures via Ford IDS

1. First, delete all error codes with a diagnostic device of your choice.

The following steps are explained using Ford IDS, but can also be carried out with alternative software.

2. Start the Ford diagnostic unit IDS and connect to the vehicle via the DLC diagnostic plug.
3. Select the Toolbox in the header (3rd icon) and then click on (Powertrain) and (ASM Service Functions). Confirm your choice with the check mark in the lower right corner.
4. Now follow the procedures that appear on the screen. These should be: "Shift actuator bleed, "Learn transmission" and "Learn clutch touch point".

AUDI**AUDI A3 8P 2003-2012**

DSG 6 - DQ250.....	48
DSG 7 - DQ200.....	70

AUDI TT 8N 1998-2006

DSG 6 - DQ250.....	48
--------------------	----

AUDI TT 8J 2006-2014

DSG 6 - DQ250.....	48
DSG 7 - DQ200.....	70

AUDI A1 8X 2010-2018

DSG 7 - DQ200.....	70
--------------------	----

FORD**FORD FIESTA V 2001-2008**

Ford durashift - EST.....	108
---------------------------	-----

FORD FUSION 2002-2012

Ford durashift - EST.....	108
---------------------------	-----

MAZDA**MAZDA 2 2003-2007**

Ford durashift - EST.....	108
---------------------------	-----

MAZDA 2 2007-2014

Ford durashift - EST.....	108
---------------------------	-----

MERCEDES-BENZ**MERCEDES-BENZ A-CLASS W168 1997-2004**

Mercedes-Benz 722.7 - Siemens FTC.....	4
--	---

MERCEDES-BENZ Vaneo W414 2002-2005

Mercedes-Benz 722.7 - Siemens FTC.....	4
--	---

MERCEDES-BENZ A-CLASS W169 2004-2012

Mercedes-Benz 722.8 - Temic VGS.....	18
--------------------------------------	----

MERCEDES-BENZ B-CLASS W245 2005-2011

Mercedes-Benz 722.8 - Temic VGS.....	18
--------------------------------------	----

MERCEDES-BENZ M-CLASS W164 2006-2012

Mercedes-Benz 722.9 - 7G-tronic.....	32
--------------------------------------	----

MERCEDES-BENZ M-CLASS W166 2011-2015

Mercedes-Benz 722.9 - 7G-tronic.....	32
--------------------------------------	----

MERCEDES-BENZ SLK W171, R171 2004-2011

Mercedes-Benz 722.9 - 7G-tronic.....	32
--------------------------------------	----

MERCEDES-BENZ C-CLASS W203, CL203, S203 2000-2007

Mercedes-Benz 722.9 - 7G-tronic.....	32
--------------------------------------	----

MERCEDES-BENZ C-CLASS W204, C204, S204 2007-2014

Mercedes-Benz 722.9 - 7G-tronic.....	32
--------------------------------------	----

MERCEDES-BENZ CLK W209, A209, C209 2002-2009

Mercedes-Benz 722.9 - 7G-tronic.....	32
--------------------------------------	----

MERCEDES-BENZ E-CLASS W211, S211 2002-2008

Mercedes-Benz 722.9 - 7G-tronic.....	32
--------------------------------------	----

MERCEDES-BENZ E-CLASS W212 S212, C207, A207 2009-2016

Mercedes-Benz 722.9 - 7G-tronic.....	32
--------------------------------------	----

MERCEDES-BENZ CL-CLASS W215 1998-2005

Mercedes-Benz 722.9 - 7G-tronic.....	32
--------------------------------------	----

MERCEDES-BENZ CL-CLASS W216 2006-2013

Mercedes-Benz 722.9 - 7G-tronic.....	32
--------------------------------------	----

MERCEDES-BENZ CLS W219, C219 2004-2010

Mercedes-Benz 722.9 - 7G-tronic.....	32
--------------------------------------	----

MERCEDES-BENZ S-CLASS W220 1998-2005

Mercedes-Benz 722.9 - 7G-tronic.....	32
--------------------------------------	----

MERCEDES-BENZ S-CLASS W221 2005-2013

Mercedes-Benz 722.9 - 7G-tronic.....	32
--------------------------------------	----

MERCEDES-BENZ SL W230, R230 2001-2012

Mercedes-Benz 722.9 - 7G-tronic.....	32
--------------------------------------	----

MERCEDES-BENZ SL W231, R231 2012-2019

Mercedes-Benz 722.9 - 7G-tronic.....	32
--------------------------------------	----

MERCEDES-BENZ R-CLASS W251, V251 2006-2014

Mercedes-Benz 722.9 - 7G-tronic.....	32
--------------------------------------	----

MERCEDES-BENZ VITO / V-CLASS W447 2015-2019

Mercedes-Benz 722.9 - 7G-tronic.....	32
--------------------------------------	----

MERCEDES-BENZ G-CLASS W461, W463 1979-2019

Mercedes-Benz 722.9 - 7G-tronic.....	32
--------------------------------------	----

MERCEDES-BENZ GL-CLASS X164 2006-2012

Mercedes-Benz 722.9 - 7G-tronic.....	32
--------------------------------------	----

MERCEDES-BENZ GLK-CLASS X204 2008-2015

Mercedes-Benz 722.9 - 7G-tronic.....	32
--------------------------------------	----

SEAT**SEAT ALHAMBRA 710 2010-2019**

DSG 6 - DQ250.....	48
--------------------	----

SEAT ALTEA 5P1, 5P5, 5P8 2004-2015

DSG 6 - DQ250.....	48
DSG 7 - DQ200.....	70

SEAT LEON 1P1 2005-2012

DSG 6 - DQ250.....	48
DSG 7 - DQ200.....	70

SEAT TOLEDO III 5P2 2004-2009

DSG 6 - DQ250.....	48
--------------------	----

SEAT IBIZA V 6J5, 6J1, 6J8 2008-2017

DSG 7 - DQ200.....	70
--------------------	----

SEAT TOLEDO III 5P2 2004-2009

DSG 7 - DQ200.....	70
--------------------	----

ŠKODA**ŠKODA FABIA 5J 2007-2014**

DSG 7 - DQ200.....	70
--------------------	----

ŠKODA OCTAVIA 1Z 2004-2013

DSG 6 - DQ250.....	48
DSG 7 - DQ200.....	70

ŠKODA ROOMSTER 5J 2006-2015

DSG 7 - DQ200.....	70
--------------------	----

ŠKODA SUPERB 3T 2008-2015

DSG 6 - DQ250.....	48
DSG 7 - DQ200.....	70

ŠKODA YETI 5L 2009-2017

DSG 6 - DQ250.....	48
DSG 7 - DQ200.....	70

VAUXHALL**VAUXHALL AGILA A 2000-2007**

Bosch Easytronic - F13/F17 MTA.....	88
-------------------------------------	----

VAUXHALL ASTRA G 1998-2004

Bosch Easytronic - F13/F17 MTA.....	88
-------------------------------------	----

VAUXHALL ASTRA H 2004-2010

Bosch Easytronic - F13/F17 MTA.....	88
-------------------------------------	----

VAUXHALL ASTRA J 2009-2015

Bosch Easytronic - F13/F17 MTA.....	88
-------------------------------------	----

VAUXHALL COMBO C 2001-2011

Bosch Easytronic - F13/F17 MTA.....	88
-------------------------------------	----

VAUXHALL CORSA C 2000-2006

Bosch Easytronic - F13/F17 MTA.....	88
-------------------------------------	----

VAUXHALL CORSA D 2006-2014

Bosch Easytronic - F13/F17 MTA.....	88
-------------------------------------	----

VAUXHALL MERIVA A 2003-2010

Bosch Easytronic - F13/F17 MTA.....	88
-------------------------------------	----

VAUXHALL TIGRA TWINTOP 2004-2009

Bosch Easytronic - F13/F17 MTA.....	88
-------------------------------------	----

VAUXHALL SIGNUM 2003-2008

Bosch Easytronic - F13/F17 MTA.....	88
-------------------------------------	----

VAUXHALL VECTRA C 2002-2008

Bosch Easytronic - F13/F17 MTA.....	88
-------------------------------------	----

VAUXHALL ZAFIRA B 2005-2011

Bosch Easytronic - F13/F17 MTA.....	88
-------------------------------------	----

VOLKSWAGEN**VW CADDY III 2K, 2C 2004-2015**

DSG 6 - DQ250.....	48
DSG 7 - DQ200.....	70

VW CC 358 2011-2019

DSG 6 - DQ250.....	48
--------------------	----

VW EOS 1F7, 1F8 2006-2015

DSG 6 - DQ250.....	48
--------------------	----

VW GOLF IV 1J 1997-2004

DSG 6 - DQ250.....	48
--------------------	----

VW GOLF V 1K 2003-2009

DSG 6 - DQ250.....	48
DSG 7 - DQ200.....	70

VW GOLF VI 5K1, 517, AJ5 2008-2012

DSG 6 - DQ250.....	48
DSG 7 - DQ200.....	70

VW JETTA III 1K2 2005-2011

DSG 6 - DQ250.....	48
DSG 7 - DQ200.....	70

VW JETTA IV 162, 16A 2011-2019

DSG 6 - DQ250.....	48
DSG 7 - DQ200.....	70

VW NEW BEETLE 5C1 2011-2019

DSG 6 - DQ250.....	48
DSG 7 - DQ200.....	70

VW PASSAT 3C2, 3C5 2005-2010

DSG 6 - DQ250.....	48
DSG 7 - DQ200.....	70

VW PASSAT 362, 365 2010-2014

DSG 6 - DQ250.....	48
DSG 7 - DQ200.....	70

VW SCIROCCO 137 2008-2014

DSG 6 - DQ250.....	48
--------------------	----

VW SHARAN 7N 2010-2019

DSG 6 - DQ250.....	48
--------------------	----

VW TIGUAN 5N 2007-2016

DSG 6 - DQ250.....	48
--------------------	----

VW TOURAN 1T1, 1T2 2003-2010

DSG 6 - DQ250.....	48
DSG 7 - DQ200.....	70

DISCLAIMER

ACtronic takes the utmost care to ensure that the data in this diagnostic guide are reliable and up to date. However, the data shown may still contain inaccuracies or be incomplete. ACtronic does not accept any liability for any imperfections or inaccuracies in the information provided in this diagnostic guide and reserves the right to change the content of the information provided. ACtronic is not liable for damages resulting from inaccuracies or omissions in the information and services offered. If in doubt, always consult the manufacturer's official documentation.

COPYRIGHT

All ACtronic LTD publications and statements are protected by copyright and other intellectual property rights. All rights reserved. Except for personal and non-commercial use, no part of these publications and statements may be reproduced, copied or otherwise disclosed in any way without the prior written consent of ACtronic LTD.



REMANUFACTURED TO LAST

 WWW.ACTRONICS.CO.UK

 +44 (0)1206 849920

 INFO@ACTRONICS.CO.UK

 UNIT 3, BRUNEL COURT, BRUNEL WAY
CO4 9XP COLCHESTER, ESSEX
UNITED KINGDOM